

ELECTRIC PROPULSION FOR LUNAR EXPLORATION AND LUNAR BASE DEVELOPMENT

N 9 3 - 1 7 4 1 9

Bryan Palaszewski

Mail Stop 500-219
NASA Lewis Research Center
21000 Brookpark Road
Cleveland OH 44135

Using electric propulsion to deliver materials to lunar orbit for the development and construction of a lunar base was investigated. Because the mass of the base and its life-cycle resupply mass are large, high specific impulse propulsion systems may significantly reduce the transportation system mass and cost. Three electric propulsion technologies [arcjet, ion, and magneto-plasma-dynamic (MPD) propulsion] were compared with oxygen/hydrogen propulsion for a lunar base development scenario. Detailed estimates of the orbital transfer vehicles' (OTVs) masses and their propellant masses are presented. The fleet sizes for the chemical and electric propulsion systems are estimated. Ion and MPD propulsion systems enable significant launch mass savings over O_2/H_2 propulsion. Because of the longer trip time required for the low-thrust OTVs, more of them are required to perform the mission model. By offloading the lunar cargo from the manned O_2/H_2 OTV missions onto the electric propulsion OTVs, a significant reduction of the low Earth orbit (LEO) launch mass is possible over the 19-year base development period.

NOMENCLATURE

ACS	Attitude control subsystem
ASE	Advanced space engine
CDS	Command and data subsystem
H_2	Hydrogen
I_{sp}	Specific impulse ($lb_f\text{-sec}/lb_m$)
L/D	Lift-to-drag ratio
LEO	Low Earth orbit
LLO	Low lunar orbit
L-2	Earth-Moon libration point 2
MPD	Magneto-plasma-dynamic
MSFC	Marshall Space Flight Center
NEP	Nuclear-electric propulsion
NH_3	Ammonia
NSO	Nuclear-safe orbit
OTV	Orbital transfer vehicle
O_2/H_2	Oxygen/hydrogen
PPU	Power processing unit
RCS	Reaction control subsystem
Telecom	Telecommunication subsystem
TVS	Thermodynamic vent system
T/W	Thrust-to-weight
VCS	Vapor-cooled shield
Xe	Xenon
ΔV	Velocity change (km/sec)

INTRODUCTION

To construct a lunar base, large propulsion systems to transport personnel and material to the Moon are required. Many missions are planned, including preliminary exploration of lunar base sites, lunar base construction missions, and base maintenance missions. The choice of the types of lunar transfer propulsion systems is

dependent upon the factors of cost, trip time, safety, and capability. A mixed fleet of systems that can fulfill all the lunar base transportation system needs is a potential optimum or "best" solution.

In finding the best way to develop a lunar transportation system, a mix of several propulsion systems to be used for both unmanned cargo missions and manned assembly crew missions can be considered. Three electric propulsion options are available to perform complementary missions with the baseline chemical propulsion systems for the lunar base transportation missions. Each of these electric propulsion options is capable of delivering cargo to low lunar orbit (LLO). Because of the low thrust produced by the electric orbital transfer vehicles (OTVs), the lunar-transfer trip time is long: 100-300 days. Personnel are not transported on these OTVs; they are delivered with the high-thrust chemical propulsion OTVs. By offloading the cargo onto the low-thrust OTVs, the cost of constructing a lunar base, as measured by the initial mass required in LEO, may be significantly reduced.

LUNAR EXPLORATION AND THE LUNAR BASE

A lunar base is being considered as a possible major NASA initiative (Ride, 1987). At the base, a large number of scientific experiments will be conducted. Using lunar industrial processes to produce oxygen from the lunar soil is also a planned base activity (Carroll, 1983).

To construct and maintain the lunar base, a large number of people and a large mass of material must be delivered to the Moon. Table 1 provides the payload masses for the base (Eagle Engineering, 1984). The construction phase is 19 years. Prior to the lunar base delivery to the Moon's surface, a number of exploratory missions are needed. Small communication satellites and surface rovers will be placed into lunar orbit and on the surface respectively.

TABLE 1. Lunar base payload masses.

Payload	Mass (kg)		Number of Payloads
	Up	Down	
GEO-Mapper	500	0	2
Surface Rover	4,000	0	6
Heavy Delivery	35,000	0	10
Base Set-Up and Ops	32,000	6,000	8
Ops and Supply	19,500	7,000	3
Heavy Delivery	22,500	1,000	16
Ops (+2T)	12,500	7,500	4
Resupply	19,500	7,500	3
Crew Rotation	14,500	7,500	3
L2 Communications Satellite	2,000	0	1
Resupply	22,000	10,000	15
Crew Rotation	17,000	10,000	7

After the initial surface reconnoitering, a site will be selected for the base. A series of unmanned payload delivery missions is required for the base construction. Over the 19-year construction phase, a total of 1,602,500 kg is delivered to LLO.

In constructing a lunar base, the ability to continuously deliver large masses to lunar orbit will be essential. Using chemical propulsion, the cost of placing these masses in Earth orbit and finally in lunar orbit will be high. Figure 1 compares the mass of a chemical O₂/H₂ OTV to OTVs using ion and magneto-plasma-dynamic (MPD) propulsion. This analysis uses a 35,000-kg payload delivered to LLO from LEO; the OTV with no payload is returned to LEO. An O₂/H₂ OTV using a 475-lb_f-sec/lb_m specific impulse (I_{sp}) requires a propellant mass of 77,450 kg to perform this mission. With ion or MPD propulsion at a 5000-lb_f-sec/lb_m I_{sp}, the propellant mass is reduced to 13,300 kg and 12,250 kg, respectively. These electric propulsion systems can reduce the propellant mass needed by 64,150 and 65,200 kg per flight.

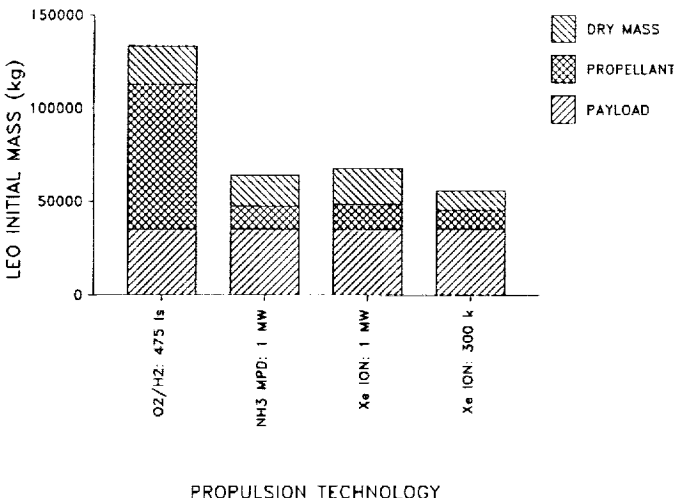

Fig. 1. Propulsion system mass comparison.

MISSION ANALYSIS

Mission analyses for each of the electric propulsion OTVs and the chemical propulsion OTVs were conducted. The ΔV for the various OTV maneuvers and their impact on the lunar transfer mission are discussed. The effect of nodal regression on the launch of the OTV payload delivery missions is described. These results are used to compute the trip times and the propellant mass for the various orbit-transfer maneuvers.

Propulsion requirements are driven by the orbit-transfer and the orbit nodal-regression ΔVs. Both low-thrust orbit transfers, high-thrust all-impulsive orbit transfers, and aerobraked orbit transfers are addressed. Nodal regression of the Moon's orbit constrains the servicing interval and the spacecraft departure time selection. Parametric analyses describing the minimization of the nodal-regression ΔV for a lunar orbit transfer are presented.

Mission ΔV

The primary ΔV for the lunar missions is the orbit-transfer ΔV. In the transfer from LEO to LLO, the OTV departs from LEO, a 28.5° inclination, 500-km-altitude orbit; the LLO is a 100-km-altitude, 0.0° inclination orbit. Table 2 provides the ΔVs used for the low-thrust and the high-thrust orbit transfers. The one-way high-thrust ΔV for the Earth departure (with no gravity losses) is 3.058 km/sec.

Gravity Losses

Gravity losses associated with the medium thrust-to-weight (T/W) nonimpulsive firings of the chemical propulsion systems were estimated using (Robbins, 1986)

$$\Delta V_{gl} = (\mu/24 r_o^3) \Delta V_1 t_b^2 [1 - (\mu/(r_o(V_o + \Delta V_1)^2))]$$

where ΔV_{gl} = gravity-loss ΔV penalty (km/sec); μ = Earth gravitational constant = 398,601.3 km³/sec²; r_o = radial orbital distance (km); ΔV₁ = impulsive ΔV (km/sec); t_b = thruster firing time (sec); and V_o = initial elliptical orbit velocity (km/sec).

For the chemical OTVs, the gravity losses were minimized by using a T/W of 0.1. The OTV thrust level was fixed at 133,340 N (30,000 lb_f); by selecting the high thrust level, the LEO-LLO ΔV_{gl} was less than 100 m/sec.

To reduce the high-thrust LEO-return ΔV, aerobraking is used. A 90-km entry altitude is assumed; the OTV provides the circularization ΔV from the 90-km aerobraking altitude to the 500-km Earth-return altitude. The OTV would then rendezvous with the space station. During the aerobraking maneuver, no orbit plane change occurs; the OTV delivers any required plane change

TABLE 2. Lunar orbit transfer ΔV.

OTV Type and Maneuver	ΔV (m/sec)
High Thrust	
LEO Departure and Trajectory Correction	3153
LLO Insertion	900
LLO Departure	900
Trajectory Correction and LEO Insertion	250
Low Thrust	
LEO Departure and LLO Insertion	8000
LLO Departure and LEO Insertion	8000

prior to the atmospheric entry. For an aerobraked return, including the circularization burn and the LLO departure, the ΔV is 1.093 km/sec. An added 57 m/sec is provided for gravity losses and the trajectory correction maneuvers between LLO and LEO.

With the low-thrust case, the ΔV is 7.80 km/sec (Carroll, 1983). For this study, a 200-m/sec ΔV was added for nonminimum energy LEO-LLO transfers; the total one-way ΔV is therefore 8.00 km/sec.

Servicing Requirements

In planning the OTV departures, the nodal regression of the LEO and the Moon must be considered. Nodal regression is the rotation of an orbit's line of nodes. This rotation is caused by the Earth's oblateness or nonsphericity. If the OTV departure time is not carefully planned, a large ΔV penalty may be incurred.

Figure 2 provides the LEO-Moon nodal-regression ΔV , using the method in Edelbaum (1961) and Palaszewski (1986). The ΔV is plotted against the servicing interval. A judicious selection of the orbit transfer departure time can significantly reduce the required OTV ΔV . Every 55 days, the nodal regression ΔV reaches a minimum. In this analysis, the OTV departures coincide with this minimum nodal ΔV .

Nuclear-Safe Orbit

A nuclear OTV may require a minimal deployment altitude called a nuclear-safe orbit (NSO). An NSO is an orbit that precludes a reactor reentry in less than 300 yr (Buden and Garrison, 1984). No official NSO altitude has been determined; a 500- to 1000-km altitude range is possible. If the NSO altitude is higher than the space station altitude, an added chemical-propulsion OTV, a nonnuclear electric propulsion OTV, or an orbital maneuvering vehicle (OMV) may be required. This OMV or OTV will deliver the nuclear OTV to its NSO and service it after every mission. In this study, a 500-km NSO was assumed. Therefore, no added servicing OMV or OTV was required.

Flight Performance Reserves

An added ΔV is provided for reaction control and flight performance reserves. During the rendezvous with the space station and for rendezvous in lunar orbit, a high-thrust reaction control subsystem (RCS) will be required; docking disturbances created by the contact of the OTV with the station must be negated. For each orbit transfer, there is also some variation in the main propulsion system performance. This RCS will provide the flight performance reserves if it is necessary to augment the OTV main propulsion system. In each OTV design, an O_2/H_2 RCS is provided; it is designed to deliver a 100-m/sec ΔV to a 45,360-kg (100,000-lb_m) initial-mass spacecraft. A 45,360-kg mass was chosen as a representative OTV wet mass. Using a 450-lb_f-sec/lb_m I_{sp} , the RCS propellant mass required is 1016 kg.

PROPULSION OPTIONS AND PROPULSION TECHNOLOGIES

OTV Designs

Cryogenic O_2/H_2 OTVs are being considered for lunar missions (Ride, 1987; Carroll, 1983; Eagle Engineering, 1984; General Dynamics, 1985; Boeing, 1986; Martin Marietta, 1985). Electric propulsion options considered in this study were the thermal-arcjet, the MPD, and ion propulsion. Both expendable and

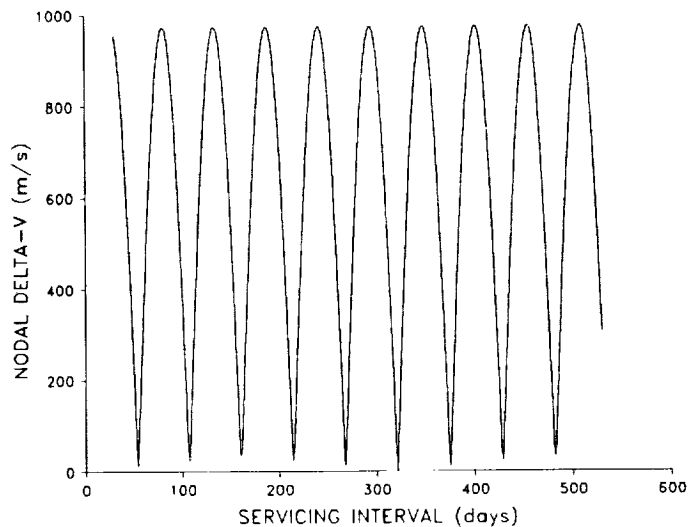

Fig. 2. Nodal regression ΔV .

reusable OTVs are being considered for the resupply of a lunar base. In this study, only reusable OTVs were analyzed.

Chemical OTV. Figure 3 depicts the chemical OTV design (Park, 1987). A conical lifting-brake aerobrake is assumed. This OTV design has a low lift-to-drag (L/D) ratio: 0.1-0.2. Each of the OTV main engines retracts behind a thermally protected door in the aerobrake. To prevent reentry wake impingement on the payload during aerobraking, a 50-ft-diameter aerobrake was assumed (General Dynamics, 1985).

Nuclear-electric OTV. A nuclear-electric OTV is shown in Fig. 4 (Jones, 1986). In this design, the nuclear reactor is separated from the payload and the propulsion system by a boom. This separation of the payload and the reactor is required to minimize the radiation effects on the payload. The OTV will fly in a gravity-gradient-stabilized mode; the most massive part of the OTV will point toward the Earth with the boom aligned with the Earth gravity vector. For this OTV, inert gas Xe-ion, NH_3 MPD, and H_2 arcjet thrusters were considered.

Solar-electric OTV. A solar-electric OTV is depicted in Fig. 5 (Aston, 1986). A 100- and a 300-kW solar array are assumed. As with the nuclear-electric OTV, the ion-electric propulsion system

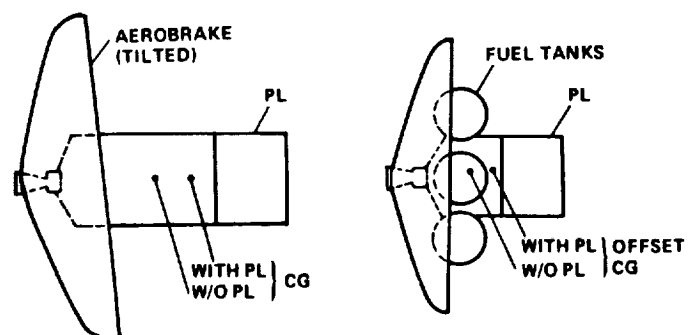

Fig. 3. Chemical OTV.

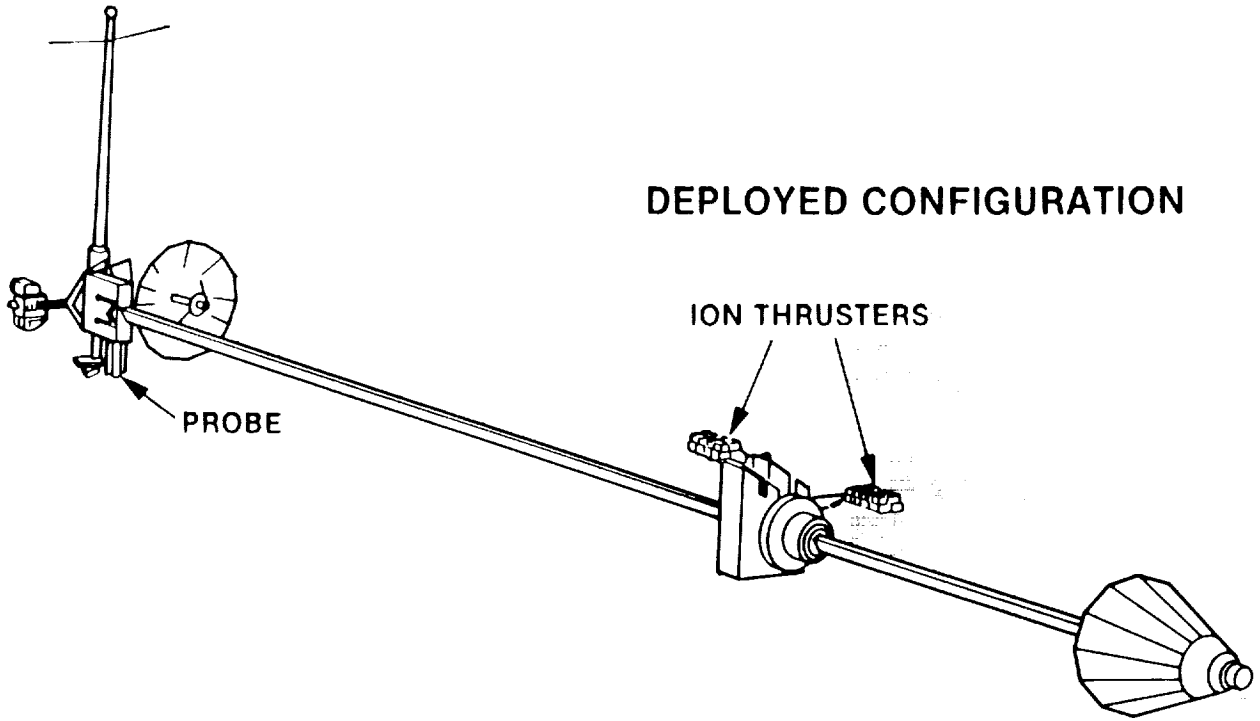

Fig. 4. Nuclear-electric OTV.

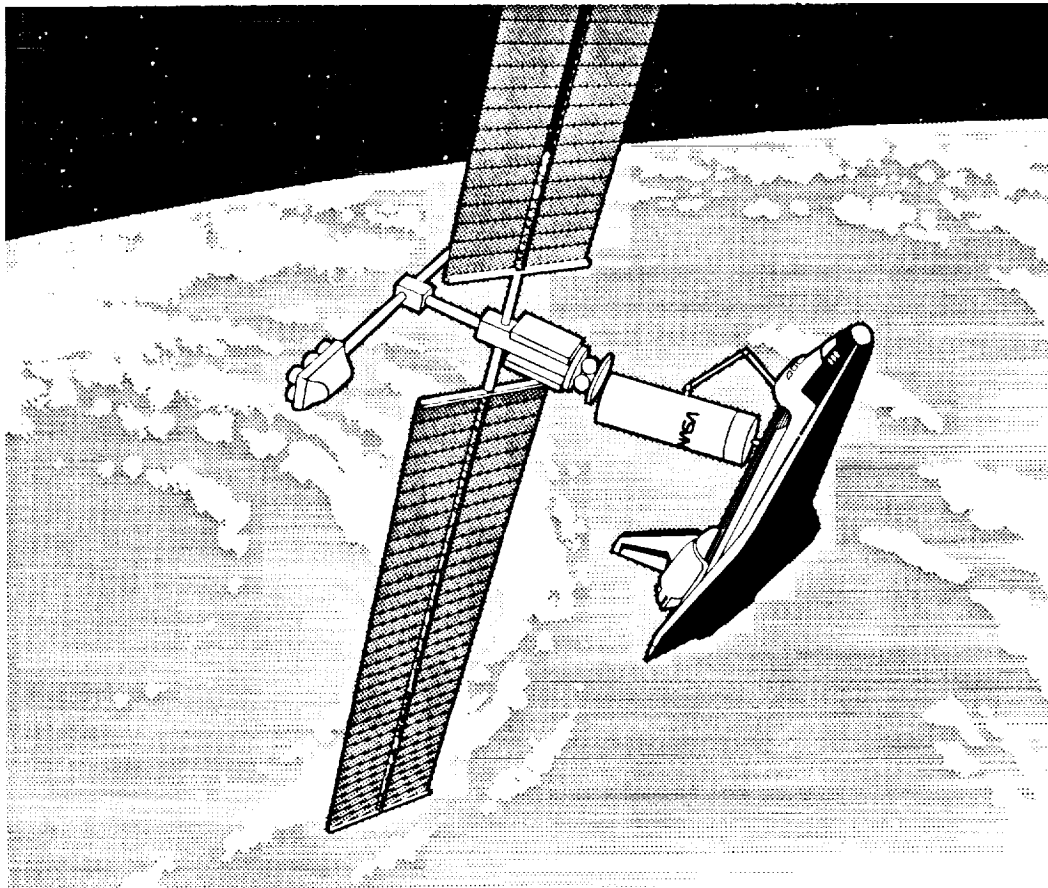

Fig. 5. Solar-electric OTV.

uses an inert gas Xe propellant. Similar OTVs were designed for the arcjet propulsion system; H₂ propellants were assumed for these OTVs. No solar-powered MPD systems were considered.

PROPULSION SYSTEM DESIGN

Main Engine and Thrusters

Table 3 shows the propulsion performance of the OTV designs. A 475-lb_f-sec/lb_m O₂/H₂ I_{sp} was assumed (*General Dynamics*, 1985). Each chemical OTV uses a 133,350-N thrust level. For the O₂/H₂ OTV the advanced space engine (ASE) mass and performance were assumed (*General Dynamics*, 1985).

For each of the low-power electric propulsion systems, a 50-kW power input per thruster was assumed. For a 100-kW propulsion system, three thrusters are required; one thruster is provided for redundancy. The 300-kW OTV needs six thrusters and two redundant thrusters are provided. At a 1-MW power level, a minimum of 20 50-kW thrusters are needed. The propulsion system complexity and mass will be reduced if a higher-power-level thruster is available.

The propulsion system mass reductions for OTVs with higher thruster power levels were investigated; a 500-kW ion thruster design for the high-power 1-MW Xe-ion OTV was assumed. One redundant thruster is provided on the OTV. For the 1-MW H₂-arcjet OTV, a 200-kW thruster power level was assumed. The OTV operates with five thrusters; three thrusters are added for redundancy. Each MPD thruster uses a 1-MW power level. For a 341-day trip time, five thrusters will be fired in series to deliver the total propulsion system firing time; three thrusters are added for redundancy.

TABLE 3. Propulsion system performance.

System	I _{sp} (lb _f -sec/lb _m)	Input P (kW)	Efficiency (Thruster and PPU)
O ₂ /H ₂	475	n/a	
H ₂ Arcjet	1,500	50	0.49
H ₂ Arcjet	1,500	200	0.49
Xe Ion	5,000	50	0.72
Xe Ion	5,000	500	0.72
Xe Ion	20,000	500	0.89
NH ₃ MPD	5,000	1000	0.50

Aerobrake

The aerobrake mass is 15% of the aeroentry mass (*Eagle Engineering*, 1984). Included in the aeroentry mass is the OTV dry mass, the payload that is returned to LEO, the propellant that is on board the OTV for the circularization firing after aerobraking, and the aerobrake itself. For the baseline O₂/H₂ system, the aerobrake mass is 2973 kg.

Electric Power System

For the chemical OTVs, a fuel cell-based power system was assumed (*Martin Marietta*, 1985). This power system provides a 0.33-kW power level for a 6- to 10-day mission. Power systems for the electric OTVs were solar arrays and nuclear reactors. Power levels of 100 kW to 1 MW were considered. An end-of-life 7-kg/kW solar array specific mass was assumed for the 100- and the 300-kW arrays (*Aston*, 1986), and for the 1-MW reactor, a 5-kg/kW and a 10-kg/kW reactor specific mass were assumed

(*Sercel*, 1987). The reactor mass includes the OTV boom mass (the boom separates the payload from the reactor and isolates it from the reactor's radiation).

A solar array will experience radiation degradation as it passes through the Earth's Van Allen radiation belts. New solar-cell technologies, such as amorphous silicon, may significantly reduce the cell radiation damage (*Aston*, 1986). In the solar-electric OTV analyses, a 1-kg/kW effective mass penalty accounts for the radiation degradation to the array; an array with no degradation has a specific mass of 6 kg/kW. A 14.3% degradation margin is therefore included. After the array has degraded 14.3%, the array blanket would be replaced.

Power Processing Units

Power processing units (PPUs) for the electric propulsion systems used state-of-the-art power electronics and dc/dc-converter technologies (*Palaszewski*, 1986). H₂-arcjet-propulsion PPU specific masses of 0.11 kg/kW were assumed (W. Deiningner, personal communication, 1986). The ion-propulsion PPU specific mass was 0.78 kg/kW (G. Aston, personal communication, 1986) for the 1-MW ion and MPD OTV and 3.1 kg/kW (G. Aston, personal communication, 1985) for the 100-kW and 300-kW OTVs.

At high power levels, the arcjet, MPD, and ion PPU specific mass will be reduced. The PPU is composed of a power-level-dependent mass and a fixed mass that is independent of the PPU power level. For a low power level, the fixed mass is a large fraction of the total PPU specific mass. At higher power levels, the PPU fixed mass is unchanged; with a high power level, the sum of the PPU fixed mass and the power-level-dependent mass correspond to a small total PPU specific mass.

Feed System Design

Detailed propulsion feed-system mass-scaling equations for all the OTVs were derived. Each feed system includes a propellant tank, pressurization system, and feed components to provide propellant to the OTV thrusters. Figure 6 provides an Xe feed system schematic. In each feed system, a 10% ullage was assumed. Each liquid propellant tank accommodates a propellant residual mass of 1.5% of the total of the usable propellant mass and the residual propellant mass. For the supercritical propellant, a 100-psia final tank pressure was assumed; for a 4500-psia initial tank pressure, this translates into a residual mass of 1.6% of the total propellant mass.

For the O₂/H₂ system, aluminum propellant tanks with a 30-psia maximal operating pressure were assumed. The tank factor of safety is 2.0; the flange factor is 1.4. Autogenous pressurization is assumed. A 20-psia nominal tank ullage pressure is assumed. A propellant boiloff rate of 0.27 kg/hr for the H₂ and 0.11 kg/hr for the O₂ was assumed. The total boiloff mass for the 10-day mission is 91.2 kg; this mass is carried as a fixed mass penalty on the OTV dry mass.

Included in the electric propulsion module designs are detailed propellant-feed systems (*Palaszewski*, 1987). H₂ propellants for the arcjet propulsion systems, Xe propellant for the ion system, and NH₃ for the MPD propulsion system were considered. Storage pressures for the propellants are 20 psia for the liquid H₂, 150 psia for the liquid NH₃, and 4500 psia for the supercritical Xe. A 30-psia maximum operating pressure was the H₂ tank design point. For the NH₃ systems, a 170-psia maximal operating pressure was used and the maximal Xe tank pressure was 4500 psia.

A tank-wrapped vaporizer provides propellant to the HN_3 -MPD thrusters. The H_2 system uses a thermodynamic vent system/vapor-cooled shield (TVS/VCS) system to reduce propellant boiloff. For both the NH_3 -MPD and the H_2 -arcjet feed system, the vaporizer and TVS/VCS are linked to the thruster feed system; the vapor or liquid from the thermal control system is conditioned and provided to the propulsion system. Because the Xe is stored as a supercritical fluid, the propellant temperature is noncryogenic: 298 K.

Other OTV subsystems that are included are the OTV structure, the propulsion-system thermal control subsystem, the attitude control subsystem (ACS), the telecommunication subsystem (telecom), and the command and data subsystem (CDS).

RESULTS

OTV Masses

Table 4 provides a comparison of the 14 OTV dry masses. Each OTV was sized for the worst-case or largest propellant mass. Figure 7 shows the O_2/H_2 OTV sizing analysis; the largest OTV was chosen from this analysis and was used in estimating the mission model propellant mass. Staging of the O_2/H_2 OTV (a two-stage system) is required to reduce the LEO launch mass. The largest O_2/H_2 OTV is sized by two missions: the 35,000-0 mission (35,000-kg payload delivered to LLO and a 0-kg payload returned

TABLE 4. OTV masses.

System	Dry Mass (kg)	$M_{p, \text{ usable}}$ (kg)
$I_{sp} = 475 \text{ lb}_f\text{-sec/lb}_m$		
O_2/H_2	9,506.70	40,000.00
O_2/H_2	5,742.95	14,200.00
$I_{sp} = 1500 \text{ lb}_f\text{-sec/lb}_m$		
H_2 Arcjet (100 kW)	24,231.33	7,4650.48
H_2 Arcjet (300 kW)	29,701.00	8,5012.40
H_2 Arcjet (1 MW)	46,417.31	11,7882.20*
H_2 Arcjet (1MW)	35,081.76	9,5592.76†
$I_{sp} = 5000 \text{ lb}_f\text{-sec/lb}_m$		
Xe Ion (100 kW)	6,282.25	8,949.49
Xe Ion (300 kW)	8,848.22	9,939.16
Xe Ion (1 MW)	17,540.14	13,291.54*
Xe Ion (1 MW)	11,766.36	11,064.66†
$I_{sp} = 20,000 \text{ lb}_f\text{-sec/lb}_m$		
Xe Ion (1 MW)	13,861.50	27,11.00*
Xe Ion (1 MW)	8,709.05	22,73.21†
$I_{sp} = 5000 \text{ lb}_f\text{-sec/lb}_m$		
NH_3 (1 MW)	14,837.59	12,249.20*
NH_3 (1 MW)	9,529.73	10,202.01†

* Power system mass = 10 kg/kW.
 † Power system mass = 5 kg/kW.

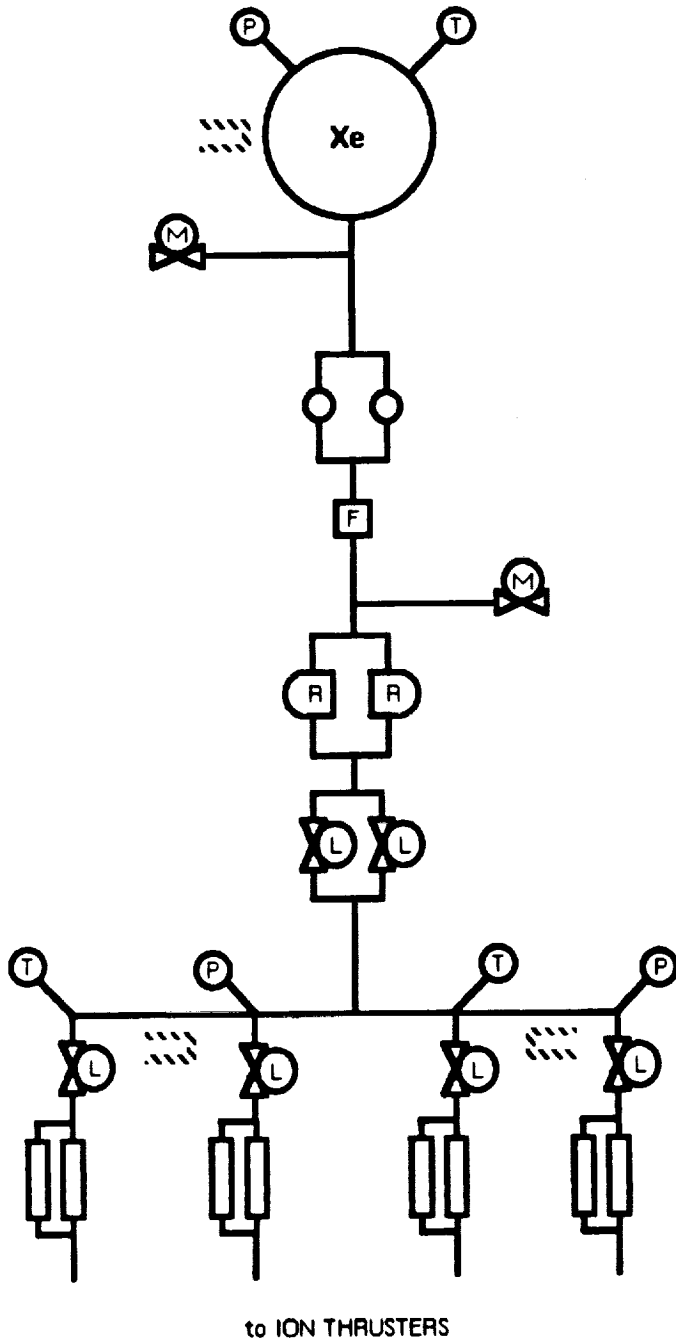

Fig. 6. Xe feed system schematic.

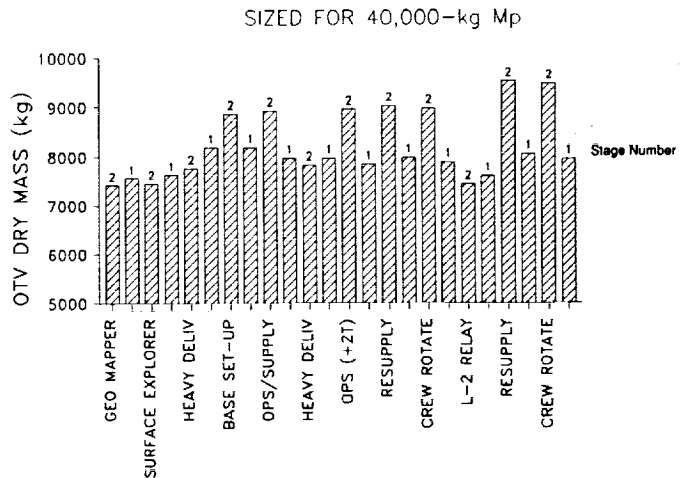

Fig. 7. O_2/H_2 OTV sizing analysis.

to LEO) sizes the 40,000-kg propellant load, and the 22,500-10,000 mission sizes the aerobrake. Figure 8 provides the 1-MW Xe-ion OTV analysis ($I_{sp} = 5000 \text{ lb}_F\text{-sec}/\text{lb}_m$ and the power system mass is 10 kg/kW). For the arcjet, the MPD, and the Xe-ion OTVs, the mission that sized the largest OTV is the 35,000-0 payload mission.

Table 5 presents a mass breakdown for the chemical-propulsion OTVs; each OTV has a mass contingency of 10% mass of the burn-out mass. All the OTVs have the same RCS, CDS, ACS, and telecom masses. The chemical O_2/H_2 OTV mass is 9507 kg. Table 6 gives the H_2 -arcjet OTV mass summary; Table 7 provides the Xe-ion OTV mass summary. The Xe-ion OTV mass is 17,540 kg and the H_2 -arcjet OTV has a 35,082-kg mass.

Propellant Masses

In Tables 8 and 9, the total mission model propellant masses for each OTV are shown. With the O_2/H_2 system, the total propellant mass is $4.7 \times 10^6 \text{ kg}$. The maximum propellant mass delivery is needed in the eighteenth year of the mission model: $6.7 \times 10^5 \text{ kg}$.

Each of the Xe-ion and the MPD OTVs can significantly reduce the total propellant mass required for the lunar base mission model. If the payloads for the base buildup were transported with

low-thrust propulsion and the manned cargo crews were delivered separately, a large LEO launch mass savings is possible. Table 8 shows the mass reduction that this operations scenario provided for the total mission model.

The timing of the payload delivery to lunar orbit is also important. With a low-thrust system, the payloads that do not require a manned presence can be sent on ahead of the personnel.

TABLE 6. H_2 -Arcjet (1-MW) OTV mass breakdown.

H_2 (M_p , usable = 95,592.76 kg)	
Subsystem	Mass (kg)
Propellant Storage and Feed	9,465.20
RCS	1,137.65
Power System, PPU, and Thrusters	5,618.92
Structure	4,779.63
Thermal Control	9,184.39
ACS, Telecom, CDS	251.00
Residuals	1,455.72
Contingency	<u>3,189.25</u>
Total	35,081.76

Power system mass = 5 kg/kW.

TABLE 7. Xe-ion (1-MW) OTV mass breakdown.

Xe (M_p , usable = 13,291.54 kg)	
Subsystem	Mass (kg)
Propulsion Main Engines	128.10
Propellant Storage and Feed	3,098.89
RCS	1,137.65
Power System and PPU	10,164.40
Structure	930.42
Thermal Control	18.70
ACS, Telecom, CDS	251.00
Residuals	216.42
Contingency	<u>1,594.56</u>
Total	17,540.14

Power system mass = 10 kg/kW.

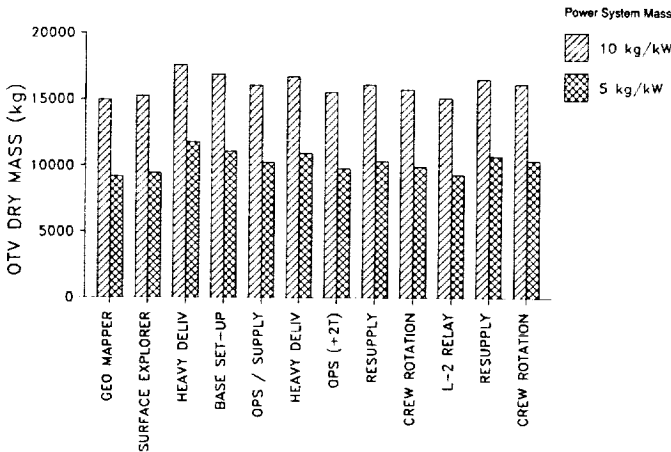

Fig. 8. Xe-ion OTV sizing analysis.

TABLE 5. Chemical OTV mass breakdown.

O_2/H_2 (M_p , usable = 40,000 kg)	
Subsystem	Mass (kg)
Aerobrake	2973.21
Propulsion Main Engines	167.83
Propellant Storage and Feed	1039.24
RCS	1,137.65
Power	291.66
Structure	2000.00
Thermal Control	172.72
ACS, Telecom, CDS	251.00
Residuals	609.14
Contingency	<u>864.25</u>
Total	9506.70

TABLE 8. OTV propellant mass requirements.

System	Total M_p (kg)	M_p Delivered* in Year 18 (kg)
$I_{sp} = 475 \text{ lb}_F\text{-sec}/\text{lb}_m$ O_2/H_2	4.65×10^6	6.73×10^5
$I_{sp} = 5000 \text{ lb}_F\text{-sec}/\text{lb}_m$		
Xe Ion (100 kW)	1.66×10^6	7.10×10^4
Xe Ion (300 kW)	1.74×10^6	8.19×10^4
Xe Ion (1 MW)	2.00×10^6	$1.19 \times 10^{4\dagger}$
Xe Ion (1 MW)	1.83×10^6	$9.42 \times 10^{4\dagger}$
$I_{sp} = 20,000 \text{ lb}_F\text{-sec}/\text{lb}_m$		
Xe Ion (1 MW)	1.35×10^6	$2.31 \times 10^{4\dagger}$
Xe Ion (1 MW)	1.31×10^6	$1.84 \times 10^{4\dagger}$
$I_{sp} = 5000 \text{ lb}_F\text{-sec}/\text{lb}_m$		
NH_3 MPD (1 MW)	1.92×10^6	$1.07 \times 10^{5\dagger}$
NH_3 MPD (1 MW)	1.76×10^6	$8.50 \times 10^{4\dagger}$

* Electric OTV propellant only.

† Power system mass = 10-kg/kW.

‡ Power system mass = 5 kg/kW.

TABLE 9. OTV propellant mass requirements.

System	Total M_p (kg)	M_p Delivered* in Year 15 (kg)
O ₂ /H ₂	4.65×10^6	6.58×10^4
H ₂ Arcjet (100 kW)	6.16×10^6	7.32×10^5
H ₂ Arcjet (300 kW)	6.96×10^6	8.56×10^5
H ₂ Arcjet (1 MW)	10.03×10^6	$1.25 \times 10^{6\dagger}$
H ₂ Arcjet (1 MW)	7.79×10^6	$9.83 \times 10^{5‡}$

* Electric OTV propellant only.

† Power system mass = 10 kg/kW.

‡ Power system mass = 5 kg/kW.

All electric propulsion OTV total propellant mass estimates include 1.19×10^6 kg of O₂/H₂.

A smaller high-thrust vehicle can be used to rendezvous with the cargo modules once they are in lunar orbit.

In each of the total propellant masses for the electric OTVs listed in Tables 8 and 9, a 1.2×10^6 -kg O₂/H₂ propellant mass is included. This mass is the total propellant mass required to fly the manned missions in the model; to make the most effective use of electric propulsion, the cargo from the manned sorties is offloaded onto the low-thrust OTVs. In this "remanifesting" of the payloads, the only payloads that fly on the O₂/H₂ OTVs are manned modules for the crew. The crews aboard the chemical OTVs would rendezvous with the payloads delivered by the low-thrust OTVs once they had arrived in LLO.

Each manned mission in the remanifested model is flown with an O₂/H₂ OTV that is sized for a 6000-kg mass flown on a round-trip lunar mission. This mass represents a 5500-kg manned mission module that supports a four-man crew (*Eagle Engineering*, 1984) and 500 kg for added support systems (power, etc.) for the module. The OTV dry mass is 5743 kg and has a usable propellant load of 14,200 kg.

In the remanifested payload delivery scheme, the payload delivered to LLO by the electric OTVs is the difference between the manned sortie missions listed in Table 1 and the 6000-kg mass for the manned module. For example, for the 32,000-kg up, 6000-kg down mission, the electric OTV would deliver a 26,000-kg up payload and return 0 kg to LEO. An O₂/H₂ OTV performs a round trip with the 6000-kg manned module.

All the missions that are unmanned in the baseline chemical propulsion scenario are conducted using electric propulsion; no payload mass changes are made with these payloads.

All the H₂-arcjet OTVs were rejected because the total mission-model propellant mass for each design exceeds the O₂/H₂ OTV mission-model propellant mass. The relatively low I_{sp} of the arcjet system combined with the high ΔV the system must deliver makes the arcjet system noncompetitive with the chemical propulsion options.

Fleet Sizes

Table 10 compares the fleet sizes for all the OTVs. For the chemical-propulsion OTVs, the minimal fleet size for all scenarios is two OTVs. The chemical propulsion trip times are short; a chemical OTV requires four to five days for a LEO-LLO orbit transfer. In an actual OTV deployment, four to six OTVs would be required; because of hardware failures, damaged OTVs, missed orbit-transfer opportunities due to nodal regression, or other

unanticipated problems, a number of added OTVs over and above the minimal fleet size is desirable.

The 100-kW Xe-ion OTVs require very large fleet sizes. The minimum total number of 100-kW electric OTVs required is 47. Array shadowing (passage of the OTV into the Earth's shadow during the orbit transfer) was included. Due to the extended trip times for the low-thrust OTVs, a large number of them are needed. As with the chemical OTVs, additional vehicles will be required to replace OTVs that are being repaired or have been damaged. Because of the large fleet sizes required, these OTVs were rejected from further consideration.

In this analysis, the effect of solar-array shadowing was included; by not including shadowing, the effects of the OTV power level and the shadowing on the OTV trip time are decoupled. If OTV shadowing is included the total fleet size increases by 20%. For example, the 100-kW Xe-ion OTV fleet size if shadowing is ignored is 39 OTVs; with shadowing included, the fleet's size is 47 OTVs.

A 1-MW OTV design can reduce the total fleet size required over the low-power OTVs. Figure 9 compares the 1-MW Xe-ion and MPD OTV fleets ($I_{sp} = 5000$ lb_f-sec/lb_m, 10-kg/kW power system). A minimum of seven Xe-ion and nine NH₃ MPD OTVs are needed. As with the chemical OTVs, additional vehicles will be required to replace OTVs that are being repaired or have been damaged.

In Fig. 9, the OTV fleet size varies from year to year. This variation is caused by the differing delivery schedules in each mission model year. For example, in year 10, there are 6 payloads, 12 payloads in year 15, and 11 payloads in year 18.

A high-power OTV can significantly reduce the LEO-LLO trip time; this causes the significant fleet-size reduction for high-power OTVs. Figure 10 provides the trip times for the Xe-ion OTVs. All the trip times are for round trips. For the 300-kW OTVs, the maximum trip time (with shadowing) is 769 days. At the 1-MW power level, the trip time is significantly reduced: 257 days. Figure 11 gives the MPD OTV trip times. A 341-day maximum trip time is required for the 1-MW OTV (10 kg/kW power system).

An important result of these fleet size and propellant mass analyses was that the fleet size of the 300-kW Xe-ion OTVs (5000-lb_f-sec/lb_m I_{sp}) and the 1-MW Xe-ion OTVs (20,000-lb_f-sec/lb_m I_{sp}) is comparable. Though the propellant mass required for the

TABLE 10. OTV minimum fleet size requirements.

System	Minimum Fleet Size	Year
O ₂ /H ₂	2	All
$I_{sp} = 5000$ lb _f -sec/lb _m		
Xe Ion (100 kW)	47	18
Xe Ion (300 kW)	18	15, 18*
Xe Ion (1 MW)	7	15, 18*
Xe Ion (1 MW)	6	18†
$I_{sp} = 20,000$ lb _f -sec/lb _m		
Xe Ion (1 MW)	17	18*
Xe Ion (1 MW)	13	15, 18†
$I_{sp} = 5000$ lb _f -sec/lb _m		
NH ₃ MPD (1 MW)	9	15, 18*
NH ₃ MPD (1 MW)	7	15, 18†

* Power system mass = 10 kg/kW.

† Power system mass = 5 kg/kW.

20,000-lb_f-sec/lb_m I_{sp} OTVs was significantly lower than the 5000-lb_f-sec/lb_m I_{sp} OTVs, the fleet size was similar: 18 for the 300-kW system and 17 for the 1-MW system. If the cost of the 300-kW solar-powered OTV were significantly lower than the 1-MW nuclear-powered OTV, the solar-electric OTV may have a cost advantage over the 20,000-lb_f-sec/lb_m I_{sp} OTVs.

Payload Remanifesting

To reduce the total mission-model propellant requirements and the OTV fleet size, variations of the OTV payload delivery capability were investigated. In this sensitivity study, the total payload of the mission model is variable. For missions in the model with multiple payload deliveries and retrievals per year, the total number of LLO missions is variable; for example, if the payload delivered to LLO on each OTV is doubled, the total number of missions flown to LLO is halved. With missions that are flown only once per year, the total mass flown to orbit is multiplied by the payload factor; no remanifesting of the other LLO payloads is addressed.

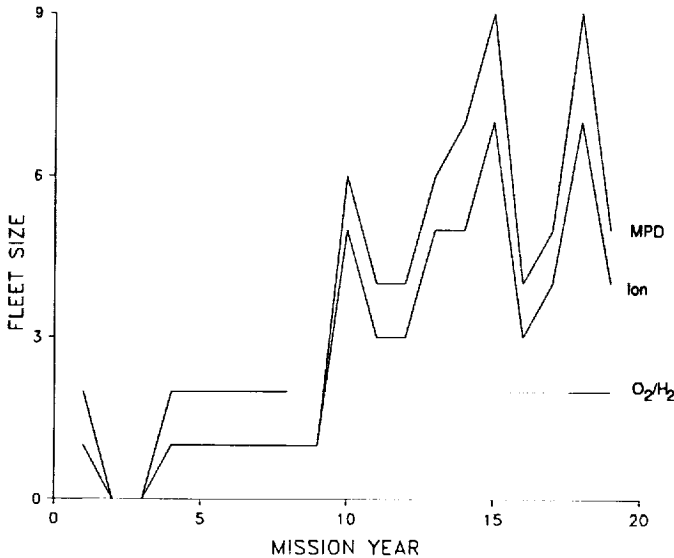

Fig. 9. Fleet sizes: 1-MW ion, 1-MW MPD, and O₂/H₂.

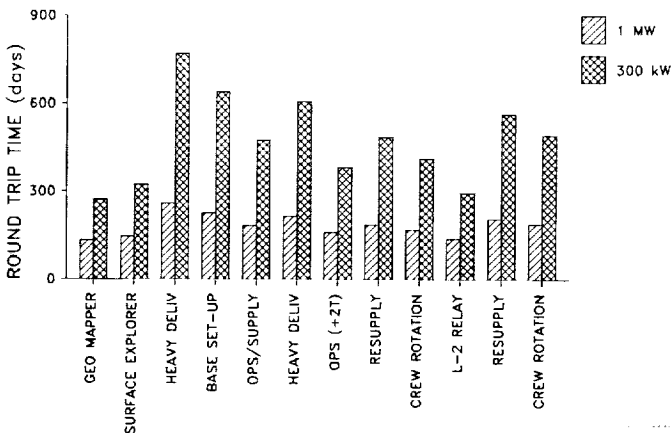

Fig. 10. Xe-ion trip times.

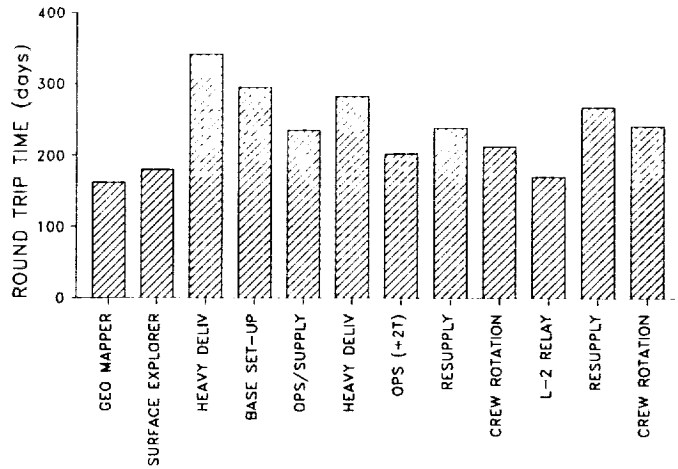

Fig. 11. MPD trip times.

This multiplication of the single-flight LLO payloads results in a significant payload mass increase. In the baseline model, five 22,500-kg up, 1000-kg down, five 22,000-kg up, 20,000-kg down, and one 17,000-kg up, 10,000-kg down flights are planned. For the Xe-ion 1-MW OTVs in year 18, at a payload factor of 2.89, the total delivered payload mass is 3.2×10^5 kg; the nominal year-18 payload mass is 2.4×10^5 kg.

By remanifesting the payload mission model, a large savings in propellant mass is possible. Remanifesting implies that the payload masses of the various missions are not fixed; they can be offloaded onto other OTV flights or combined with other OTV delivery missions. Currently, the mission model payload masses on each flight are not fixed. For example, with the heavy delivery missions, the number of cargo elements delivered on each mission is variable.

In this analysis, the mass of the OTV payload is multiplied by the OTV payload factor. For each payload factor, the required OTV mass was computed using an OTV mass-scaling equation; therefore, the OTV mass is not a fixed number for each payload factor. At each payload factor, the number of OTVs required was computed; an optimum or minimum number of OTVs for any mission model can be estimated. An OTV payload factor ranging from 0.2 to 5.0 was considered.

Figure 12 presents the minimum Xe propellant mass required for 1-MW Xe-ion OTV (power system mass is 10 kg/kW and a 500-lb_f-sec/lb_m I_{sp}) vs. the OTV payload factor. A 1-MW OTV was assumed. At a payload factor of 2.89, a minimum propellant mass is obtained.

In the data from Fig. 12, there are several local minima. The minima are the result of two effects. The first effect is the increase in the OTV size as the payload factor increases. Because the OTV size is increasing, the fleet size for each payload factor is dropping.

As the payload factor increases, the number of OTVs to perform the mission model decreases. However, as the number of OTVs decreases, there is always an integral number of them (there are either 1, 2, or n OTVs, not 2.5). The variation of the number of OTVs with the payload factor is shown in Fig. 13. The fact that the number of OTVs is an integral number and not a smooth function of the payload factor is the second effect.

Combining the effect of the OTV size increase and the fact that the number of OTVs is always an integral number causes the local minima. As shown in Fig. 12, at a payload factor of 2.89, the total propellant mass is a minimum. Another local minimum occurs at a payload factor of 2.42. The increase in propellant mass between the two payload factors is the result of the payload mass increasing on each of the OTVs and the number of OTVs remaining constant (see Fig. 13).

The minimum 1-MW Xe-ion OTV fleet size is shown in Fig. 13. A minimum fleet also occurs at a payload factor of 2.89; for the Xe-ion OTV, the minimum fleet size is 5. This represents a reduction of the total number of OTVs from seven to five. Table 11

TABLE 11. Optimal OTV payload factors.

System	Payload Factor	Fleet Savings	Total Propellant Savings (kg)
$I_{sp} = 5000\text{-lb}_f\text{-sec/lb}_m$			
Xe Ion (1 MW)	2.89	2	1.3×10^5 *
NH ₃ MPD (1 MW)	2.42	3	5.3×10^4 *

* Power system mass = 10 kg/kW.

provides the optimum payload factor and the propellant savings for the 1-MW MPD OTV and the 1-MW Xe-ion OTV. The Xe-ion propellant mass is reduced by 1.3×10^5 kg. In the MPD case, the minimum fleet occurs at a 2.42 payload factor; the number of OTVs is reduced from nine to six and the propellant mass is reduced by 5.2×10^4 kg to 6.8×10^5 kg.

In Fig. 13 the fleet size varies from nine to six MPD OTVs over the payload factor range of 0.8 to 2.4. This variation is caused by the change of the number of OTVs for the differing multiple payload deliveries. In year 15, there are three types of mission: five 22,500-1000 heavy delivery missions, three 19,400-7500 resupply missions, three 14,500-7500 crew rotation missions, and one 2000-0-kg L-2 communications satellite mission. If the payload factor is 1.5, the total number of OTVs is $4 + 2 + 2 + 1 = 9$; similarly, for a payload factor of 2.4, the total number is $3 + 1 + 1 + 1 = 6$.

Large propellant savings are possible with payload remanifesting. A large added payload-mass delivery capability to LLO also results. To achieve this large savings and added mass delivery capability, however, each mission model must have a large number of multiple-flight-per-year missions; in year 18 there are two sets of five heavy delivery and five crew rotation missions. If these multiple sets of missions were eliminated from the mission model, the payload remanifesting would not be effective and the propellant savings would drop significantly.

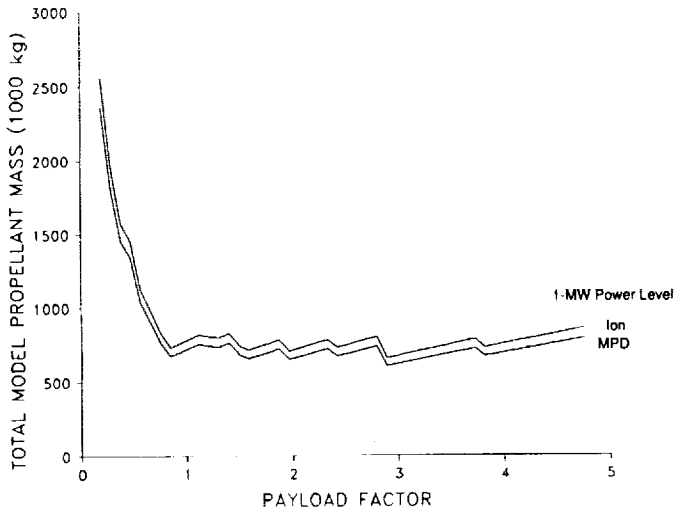

Fig. 12. Propellant mass vs. payload factor. The payload factor is a multiplier for the baseline payload mass. For example, if the payload factor is 2, the total payload mass delivered to LLO and returned to LEO is doubled.

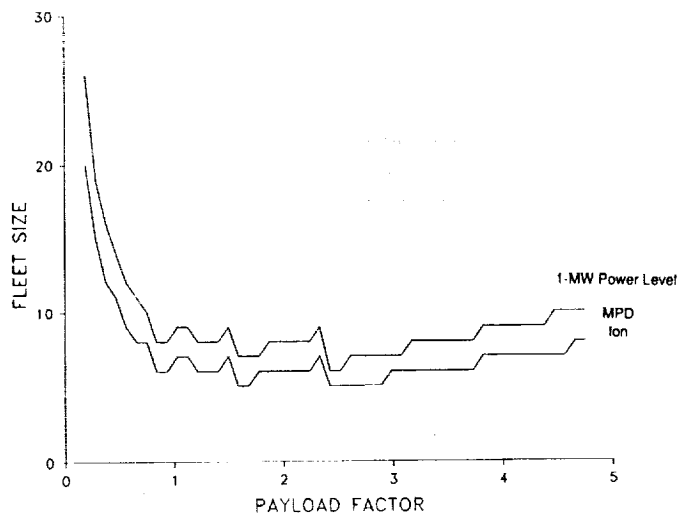

Fig. 13. Fleet size vs. payload factor.

CONCLUSIONS

Both Xe-ion and NH₃-MPD propulsion systems can significantly reduce the LEO launch mass for lunar base development missions. By combining fleets of electric propulsion OTVs and a two-stage O₂/H₂ OTV system, the total propellant mass required to perform a 19-year lunar base transportation model can be reduced by 57-72% (2.7×10^6 kg to 3.3×10^6 kg mass reduction) over an all-chemical propulsion transportation system using aerobraking.

Both solar-electric and nuclear-electric Xe-ion OTVs can enable large propellant mass savings in this transportation system; 18 and 6 OTVs are needed, respectively. Arcjet propulsion systems, using solar arrays or nuclear reactors, are not mass-competitive with chemical propulsion. Nuclear-powered MPD OTVs can also perform the mission model with a minimum nine-OTV fleet size.

The scheduling of the OTV departures to allow rendezvous of the manned chemical OTVs and the electric-propulsion cargo OTVs is required. This scheduling introduces an operational complexity that must be analyzed in more detail.

Payload remanifesting can reduce the total propellant mass required to perform the lunar base mission model. By selecting a heavier payload per OTV and reapportioning the payloads among the resized OTVs, the total transportation system is used more efficiently. This type of optimization is highly dependent upon the traffic model to LLO and LEO.

The mass reduction enabled by electric propulsion translates directly into a large launch-cost reduction. Fewer launch vehicles are required to place the total transportation system mass into LEO. Using Xe or NH₃ propellants in on-orbit storage facilities reduces the total volume of the propellant storage facilities over a cryogenic O₂/H₂ propellant storage depot.

Acknowledgments. This work was conducted by the Jet Propulsion Laboratory, California Institute of Technology, for the National Aeronautics and Space Administration.

REFERENCES

- Aston G. (1986) Advanced electric propulsion for interplanetary missions. AAS Paper 86-259.
- Boeing Aerospace Company (1986) *Orbital Transfer Vehicle Concept Definition and Systems Analysis Study, Phase II Final Review, Technical Summary*. NAS8-36107.
- Buden D. and Garrison P. (1984) Space-nuclear power system and the design of the nuclear-electric OTV. AIAA Paper 84-1447.
- Carroll W. (1983) *Research on the Use of Space Resources*. JPL Publication 83-36, Jet Propulsion Laboratory, Pasadena.
- Eagle Engineering (1984) *Impact of Lunar and Planetary Missions on the Space Station*. Final Report Number 84-85D, Contract No. NAS9-17176.
- Edelbaum T. (1961) Propulsion requirements for controllable satellites. *ARSJ*, 31, 1079-1089.
- General Dynamics Convair Division (1985) *Orbital Transfer Vehicle Concept Definition and Systems Analysis Study, Mid-Term Review, Book 1, Executive Summary, Mission System Requirements*. GDSS-SP-86-011.
- Jones R., ed. (1986) *SP-100 Planetary Mission/System Preliminary Design Study—Final Report*. JPL D-2544 (internal document).
- Martin Marietta Denver Aerospace (1985) *Orbital Transfer Vehicle Concept Definition and Systems Analysis Study, Volume II, Book 2, Aeroassist, GNEC/Aerothermal Final Review*. NAS8-36108.
- Palaszewski B. (1986) Advanced propulsion for coorbiting and polar-orbiting free flyers. AIAA Paper 86-1564.
- Palaszewski B. (1987) Geosynchronous Earth orbit base propulsion: Electric propulsion options. AIAA Paper 87-2022.
- Palaszewski B. and Krauthamer S. (1986) Arcjet- and resistojet-propulsion power processing. CPIA Conference Proceedings.
- Park C. (1987) A survey of aerobraking orbital transfer vehicle design concepts. AIAA Paper 87-0514.
- Ride S. (1987) *NASA Leadership and America's Future in Space. A Report to the Administrator*. NASA, Washington, DC. 63 pp.
- Robbins H. (1966) An analytical study of the impulsive approximation. *AIAA J*, 4, 1417-1423.
- Sercel J. (1987) *Megawatt Nuclear-Electric Propulsion: First-Order System Design and Performance Evaluation*. JPL D-3898 (internal document).