

LUNAR LANDER STAGE REQUIREMENTS BASED ON THE CIVIL NEEDS DATA BASE

John A. Mulqueen

PD32

NASA Marshall Space Flight Center

Marshall Space Flight Center AL 35812

N 93 - 17427

This paper will examine the lunar lander stages that will be necessary for the future exploration and development of the Moon. Lunar lander stage sizing will be discussed based on the projected lunar payloads listed in the Civil Needs Data Base. Factors that will influence the lander stage design will be identified and discussed. Some of these factors will be (1) lunar orbiting and lunar surface lander bases; (2) implications of direct landing trajectories and landing from a parking orbit; (3) implications of landing site and parking orbit; (4) implications of landing site and parking orbit selection; (5) the use of expendable and reusable lander stages; and (6) the descent/ascent trajectories. Data relating the lunar lander stage design requirements to each of the above factors and others will be presented in parametric form. These data will provide useful design data that will be applicable to future mission model modifications and design studies.

As a result of the findings of the National Commission on Space and the Space Leadership Report by Dr. Sally Ride, there is a renewed interest in lunar exploration. Many current lunar study activities indicate the great potential for both scientific and technological benefits from a sustained, sequential lunar exploration program that would culminate in the utilization of lunar resources. The results of many of the current conceptual engineering studies depend greatly on the specific assumptions made regarding the lunar exploration program. As part of the National Space Transportation and Support Study of 1985, NASA created the Civil Needs Data Base (CNDB). Included in the database is an outline for a sustained lunar exploration program and a detailed listing of payloads that would be transported to the Moon within that program. It was NASA's intention that this database would provide a set of program assumptions that could be used for subsequent engineering studies.

The lunar lander stages that would transport payloads to the surface would be important elements of the lunar program. The design requirements for these landers depend on many factors. It is important that these requirements be determined with the overall lunar program and the entire set of payloads within that program taken into account. The CNDB provides the necessary program assumptions and payload characteristics to serve as a basis for determining lunar lander stage requirements. There are many requirements that can be determined based on the information in the CNDB. Among these are the requirements imposed by the payloads, flight rate, propulsive requirements, configuration constraints, as well as several other mission factors.

In order to determine requirements for a lunar lander stage, it was necessary to consider two important aspects of the missions that the stages would perform. The first mission aspect that was considered was the overall mission scenario within which the stage would be operated. This aspect of the mission determines the basing options for the stage, overall energy requirements, mission duration, and the type of mission operations associated with the transportation of payloads to the lunar surface. The second mission aspect that was considered was the nature of the lunar payloads themselves. Rather than size the stages for a given

maximum payload weight it was necessary to consider the entire range of payload transportation requirements for a sequential build-up of a sustained lunar exploration program. Factors that were considered were the range of payload weights and sizes as well as the distribution of payloads within the year-by-year sequence of the lunar exploration program.

The mission scenario that was chosen in this paper was determined by considering several scenario options. These options consisted of different mission profiles and stage-base locations. There were three mission profiles that were considered, each one using a different transfer trajectory between the Earth and Moon. The first was landing from a direct transfer from low Earth orbit to the lunar surface, the second was landing from a lunar orbit, and the third was landing from the L1 libration point. These mission profiles are shown in Fig. 1 (*Martin Marietta*, 1987, pp. 131, 133, 137). The direct transfer appeared to be the most economical in terms of total propellant requirements and may be operationally less complex; however, the lander would be required to carry more than twice as much propellant than needed to land from a lunar orbit (*Martin Marietta*, 1987, p. 47). The option of landing from the Earth-Moon L1 libration point appears to offer no real advantage as far as propellant requirements for either the lunar transfer stages or the lander itself. It required 63% more propellant to land from the L1 point than from lunar orbit and 14% more propellant to travel from low Earth orbit to the L1 point than to lunar orbit (*Martin Marietta*, 1987, p. 47).

In addition to the obvious trajectory and vehicle performance considerations, the available options for establishing a transportation node or lander stage base within each mission scenario were evaluated. This assumes that the need for such a node will exist and provide operational benefits to the overall lunar transportation system. A transportation node can be envisioned as either the location of some actual platform that would provide services to spacecraft traveling to the node, or as a point in space where two spacecraft meet to perform specific mission operations. The most likely use of a transportation node would be to utilize lunar-produced resources such as liquid oxygen. The node

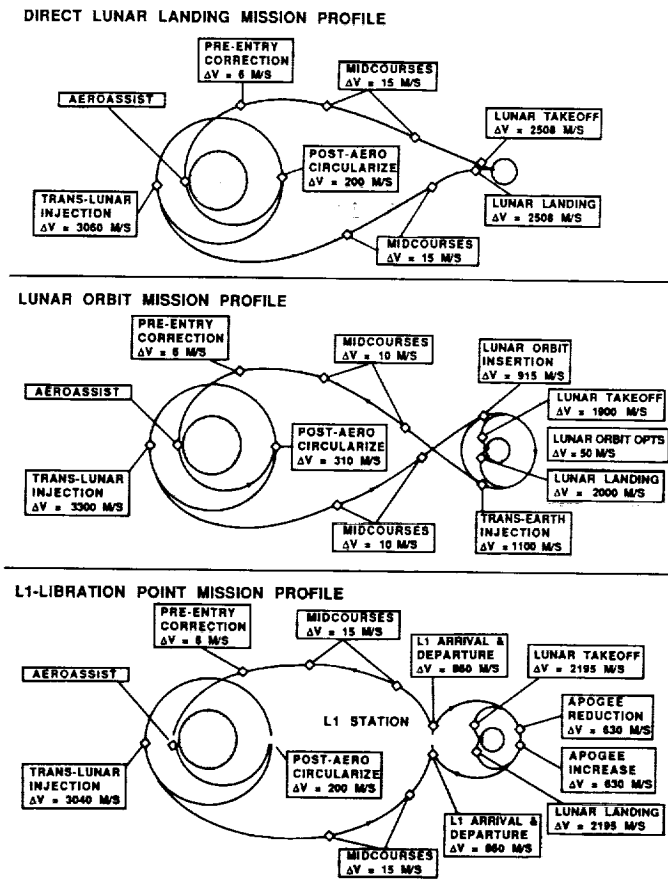

Fig. 1. Lunar mission profile options.

could serve as a base or operating location for reusable lander stages. This would reduce the transportation requirements from Earth.

The direct transfer scenario would allow for transportation nodes in either low Earth orbit or on the lunar surface. The lunar orbit scenario would allow for nodes in low Earth orbit, low lunar orbit or on the lunar surface. The L1 libration point mission scenario would allow for nodes in low Earth orbit, at the libration point or on the lunar surface. Each of these locations has advantages and disadvantages as a transportation node.

If a lunar lander transportation node were located in low Earth orbit, then lunar resources would be conveniently located where the majority of space activity occurs. However, a low Earth orbit transportation node would be a poor location for a lunar communications link or a surface sensing platform due to the large distance from the Moon and the fact that only one side of the Moon would be visible. The greatest disadvantage of basing the lunar landers in low Earth orbit would be the performance penalty of transporting the stages back and forth between the Earth and Moon each mission.

A transportation node at the L1 libration point would eliminate the need to transport landers back and forth from low Earth orbit. Unfortunately, any benefit would be more than offset by the increase in the total energy required to transport payloads or lunar resources between the Earth and Moon within the overall mission

scenario. A libration point would provide limited capability as a location for a communications link or lunar surface sensing platform since only one side of the Moon is visible. A libration point node would also have some operational disadvantages. The L1 point is not a stable libration point. The position of a platform at this node would have to be maintained by a propulsion system on the platform. This requirement could be diminished somewhat by placing the stage base in a "halo orbit" around the libration point, but this would add complexities to rendezvous operations with other spacecraft.

A transportation node on the lunar surface would allow reusable landers to be based at the same place lunar resources are produced. This would eliminate the need for an orbiting service station (*Eagle Engineering*, 1984, p. 4). Unfortunately, a strictly surface-based lander would have some operating restrictions since it would be somewhat bound to a fixed location on the lunar surface. If the lander base is located on the lunar surface, propellants brought from Earth would have to be carried all the way to the surface (*Eagle Engineering*, 1984, p. 26). This would reduce the overall payload capacity of the lunar transportation system.

An orbiting lunar station would be the most efficient location for a lander base in terms of payload vs. weight in low Earth orbit but would require propellant transfer in zero-gravity (*Woodcock*, 1985, p. 120). A fuel depot in lunar orbit would eliminate the need to transport propellants for the landers to the surface for storage. There are also some other advantages for a lunar orbit transportation node. One advantage would be better access to the farside of the Moon. Another advantage is that the lander would be less bound to a particular location on the lunar surface. Probably, the biggest advantage of using lunar orbit as a transportation node is that it provides a convenient location for exchanging payloads, crews, and lunar resources between transfer stages and lunar landers. Lunar sensing could be conducted from an orbiting station; in fact the lunar service station could be a derivative of the low Earth orbit space station, with some identical elements in addition to propellant storage capability (*JSC*, 1984, p. D-7).

The mission scenario that was chosen for this paper takes advantage of the benefits of transportation nodes on both the lunar surface and in lunar orbit. Therefore, the lunar orbit mission profile was selected. By using both locations as transportation nodes, there would be more flexibility allowed in the operation of the lunar landers. They could be maintained at a permanent surface base where liquid oxygen is produced, or parked at a lunar orbit service station. If sufficient propellant quantities could be stored in orbit, the landers would be less dependent on the surface base. Even if no lunar orbit service station were available, lunar orbit would be a useful transportation node. Payloads and crews could be efficiently exchanged in lunar orbit. Liquid oxygen from the Moon could be exchanged for liquid hydrogen from Earth. The lander could serve as its own storage facility. Its oxygen tanks would be filled on the surface and its hydrogen tanks would be filled in lunar orbit.

In order to achieve the greatest efficiency possible from the mission scenario, it must be carefully designed to minimize the overall energy requirements without restricting lunar exploration options. A scenario that would achieve these goals has been described by *Woodcock* (1985). The lunar orbit used in this scenario was a 100-km altitude polar orbit, which permits access to any point on the lunar surface since the Moon rotates underneath this orbit once every 27 days. The Earth orbit from

which lunar transfers would originate was assumed to be the space station orbit at approximately 500 km altitude and 28.5° inclination. Due to the precession of the space station orbit about the Earth's polar axis and its orientation with respect to the plane of the Moon's orbit, there is an opportunity for an in-plane transfer to the Moon approximately every 9 days (Woodcock, 1985). In order to minimize the energy requirements of the transfer trajectory, it should be designed so that the approach vector of the transfer vehicle when it reaches the Moon is in the plane of the lunar polar orbit. Similarly, the approach vector of the transfer vehicle when it returns to Earth should be in the plane of the space station orbit. A trajectory that would satisfy both these conditions is called a synchronized Earth-Moon round trip (Woodcock, 1985). Synchronism is possible when the combined angular displacements, θ , of the transfer vehicle, Moon, and line of intersection of the transfer orbit plane and space station orbit plane add up to be a complete circle (i.e., $\theta = N\pi$, $N = 2, 4, 6 \dots$).

A synchronized round-trip trajectory is shown in Fig. 2. The angular displacements of the transfer vehicle, Moon, and line of intersection of the transfer orbit and space station orbit is shown in Fig. 3. The combined angular displacement is shown to be 720° or two complete circles. This particular trajectory requires about 4 days for the transfer between the Earth and Moon and a 15-day stay time in lunar orbit. The entire round trip mission takes approximately 23 days. The ΔV requirements for this trajectory are listed below (from Woodcock, 1985, p. 119)

- Trans-Lunar Injection = 3139 M/S
- Lunar Orbit Insertion = 915 M/S
- Trans-Earth Injection = 906 M/S
- Earth Orbit Insertion = 3061 M/S (All Propulsive)
- or = 200 M/S (With Aerobrake)

It is obvious from the preceding discussion that the mission scenario and lander basing strategy would have a large influence on the requirements for a lunar lander stage. In addition to the mission scenario, it was necessary to examine one other important aspect of the mission to determine its influence on lander requirements. This second mission aspect was the nature of the payloads that would be carried on the lander stages. The most important factors in this mission aspect were the payload weights and sizes, delivery sequence, the development of the lunar infrastructure, and the number of lander flights. Most of the assumptions concerning these factors were taken directly from the NASA CNDB.

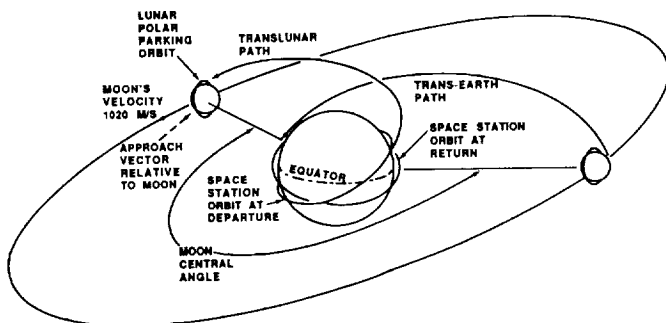

Fig. 2. Synchronized Earth-Moon round trip (Woodcock, 1985, p. 116).

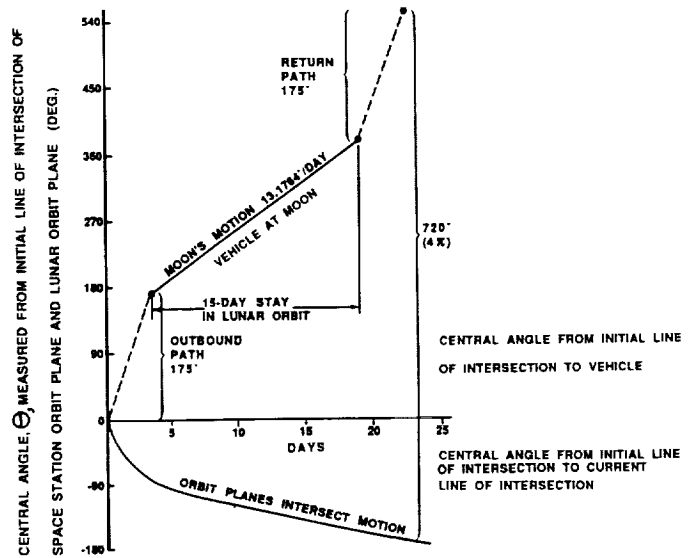

Fig. 3. Angular displacements of the transfer vehicle, Moon, and line of intersection of the transfer orbit plane and space station orbit plane.

The CNDB was developed by NASA in response to the National Security Study Directive of May 1985 (McCauley, p. i). Its purpose is to identify technology development necessary to meet U.S. space objectives for the period 1995 to 2010 and to support studies of future space transportation systems. It is a compilation of several databases and other independent inputs including the following sources: Battelle Outside Users Payload Model - 1985; Space Station Mission Data Base; NASA Technology Model; Space Station Transportation Requirements - OSS; Other Advanced/Conceptual Mission Studies; NASA Program Offices; Other Civil Agencies; Dept. of Energy; Dept. of Agriculture; Dept. of Interior, etc.; and National Commission on Space (McCauley, 1986, p. 4-2).

The lunar program portion of the CNDB contains a representative listing of all the payloads that would be transported to the Moon during the period 1995 to 2010. The description of each payload includes weight delivered to the lunar surface, payload dimensions, and flight schedule as well as other information. These payloads are defined within the framework of an assumed build-up of a lunar infrastructure that would lead to a continuous human presence on the Moon and utilization of lunar resources especially liquid oxygen. Both the assumed infrastructure and the physical characteristics of the payloads influence the requirements for the lunar landers that would be used.

The CNDB assumes that the lunar infrastructure would be created in three phases (McCauley, 1986). The first phase, which would last until 1999, would consist of unmanned robotic exploration of the Moon. Activities during this phase would include searching for frozen water or other raw materials and finding suitable locations for a lunar base. The second phase of lunar exploration would last from the year 2000 through 2004. A temporarily staffed outpost would be established on the Moon. A crew of four would visit the outpost for limited stay times of 14 to 30 days. During this phase, much of a permanent lunar base would be constructed, pilot plants for lunar resource production would be built, and scientific experiments would be carried out.

It was assumed that all landers and ascent vehicles would be expendable since no lunar-produced liquid oxygen would be available. The third phase of lunar exploration would begin in 2005. There would be continuous human presence on the Moon. Crews would be rotated from Earth to maintain a staff of 8 to 12 people at the base (McCauley, 1986). It was assumed that liquid oxygen would be produced and that a reusable lunar lander would be used to transport payloads between the surface and lunar orbit. Payloads and crews would be exchanged between transfer vehicles and the lander at a lunar orbit service station. The three-phase infrastructure just described clearly influences whether the lunar lander should be expendable or reusable. To determine additional requirements for the landers, it is necessary to examine the lunar payloads and the delivery sequence of those payloads. The lunar payloads in the CNDB are listed in Table 1. They are grouped by year but there is no particular sequence assumed within each year. Most of the payloads listed in the

CNDB are based on the study performed by *Battelle Columbus Division* (1987). They represent a wide range of possible lunar activities from astronomy to life sciences research. Included in the listing of payloads are the lunar base elements, crews, crew logistics, and descent and ascent vehicles. Each payload is given an identification number in the listing. The information shown for each payload consists of (1) weight delivered to the surface, (2) weight returned from the surface, (3) payload dimensions, and (4) number of units delivered during the year. It should be noted that there is more information available on these payloads in the CNDB than listed in Table 1.

One other factor was included in order to determine lander requirements imposed by the payloads, namely, the number of flights (or landings) that would be used to transport the payloads to the lunar surface. The number of flights determines what the payload-carrying requirements would be in terms of both payload weight and payload volume. Obviously, if fewer flights are used,

TABLE 1. Civil Needs Data Base lunar payloads.

PLID	Payload Name	Descent Weight	Ascent Weight	Length	Width	Height	Units
1996							
5024	Lunar Polar Sample Return	8,800	—	22.1	13.0	0.0	1
1997							
5024	Lunar Polar Sample Return	8,800	000	22.1	13.0	0.0	1
5034	Rover (Surf Surv)	2,200	—	14.6	8.0	0.0	1
1998							
5034	Rover (Surf Surv)	2,200	—	14.6	8.0	0.0	1
1999							
5002	Lunar Base Crew Rotation (04/014)	1,800	1,800	3.0	12.0	6.0	1
5018	Personnel Transfer Module (4 Man)	13,200	13,200	12.0	14.0	0.0	1
5027	Lunar Science and Field Geology	500	100	15.0	5.0	0.0	1
5034	Rover (Surf Surv)	2,200	—	14.6	8.0	0.0	1
5050	Lunar Lander Vehicle (Expendable)	41,660	—	13.0	14.0	0.0	2
5052	Lunar Base Crew Logistics (04/014)	300	—	3.0	3.0	3.7	1
5053	Lunar Ascent Vehicle (Expendable)	16,275	—	5.0	14.0	0.0	1
2000							
5002	Lunar Base Crew Rotation (04/014)	1,800	1,800	3.0	12.0	6.0	2
5008	Lunar Based SETI	20,000	—	32.0	14.0	0.0	1
5009	Lunar Far UV Telescope	10,000	—	15.0	6.0	10.0	1
5013	Plant (Power)(Initial)	7,000	—	20.0	15.0	0.0	1
5018	Personnel Transfer Module (4 Man)	13,200	13,200	12.0	14.0	0.0	2
5027	Lunar Science and Field Geology	500	100	15.0	5.0	0.0	1
5031	Rover (Unpressurized)	4,000	—	17.0	10.0	0.0	1
5032	Soil Mover/Crane/Constr. PH-2	38,500	—	30.0	19.0	0.0	1
5036	Comm Relay (Surf) PH-2	2,500	—	15.9	10.0	0.0	1
5050	Lunar Lander Vehicle (Expendable)	41,660	—	13.0	14.0	0.0	4
5052	Lunar Base Crew Logistics (04/014)	300	—	3.0	3.0	3.7	2
5053	Lunar Ascent Vehicle (Expendable)	16,275	—	5.0	14.0	0.0	2

TABLE 1. (continued).

PLJD	Payload Name	Descent Weight	Ascent Weight	Length	Width	Height	Units
2001							
5002	Lunar Base Crew Rotation (04/014)	1,800	1,800	3.0	12.0	6.0	3
5013	Plant (Power)(Initial)	7,000	—	20.0	15.0	0.0	2
5018	Personnel Transfer Module (4 Man)	13,200	13,200	12.0	14.0	0.0	3
5027	Lunar Science and Field Geology	500	100	15.0	5.0	0.0	1
5028	Plant (Liquid Oxygen)(Pilot)	38,500	—	36.0	14.0	0.0	1
5037	Optical Interferometer Telescope	15,000	—	15.0	15.0	0.0	1
5050	Lunar Lander Vehicle (Expendable)	41,660	—	13.0	14.0	0.0	6
5052	Lunar Base Crew Logistics (04/014)	300	—	3.0	3.0	3.7	3
5053	Lunar Ascent Vehicle (Expendable)	16,275	—	5.0	14.0	0.0	3
5082	Module Interface Mode	8,200	—	15.0	20.0	0.0	1
2002							
5011	Habitat Module PH-2	38,500	—	42.6	16.0	0.0	1
5018	Personnel Transfer Module (4 Man)	13,200	13,200	12.0	14.0	0.0	4
5027	Lunar Science and Field Geology	500	100	15.0	5.0	0.0	1
5050	Lunar Lander Vehicle (Expendable)	41,660	—	13.0	14.0	0.0	6
5053	Lunar Ascent Vehicle (Expendable)	16,275	—	5.0	14.0	0.0	4
5068	Lunar Base Crew Rotation (04/030)	1,800	1,800	3.0	12.0	6.0	4
5071	Mining Equipment (Oxygen)	38,500	—	13.7	13.7	13.7	1
5075	Lunar Base Crew Logistics (04/030)	900	—	5.0	5.0	6.0	4
2003							
5006	Plant (Power)(Advanced)	38,500	—	36.0	14.0	0.0	1
5018	Personnel Transfer Module (4 Man)	13,200	13,200	12.0	14.0	0.0	4
5027	Lunar Science and Field Geology	500	100	15.0	5.0	0.0	1
5029	Plant (Liquid Oxygen)(Production)	33,333	—	36.0	14.0	0.0	1
5050	Lunar Lander Vehicle (Expendable)	41,660	—	13.0	14.0	0.0	7
5053	Lunar Ascent Vehicle (Expendable)	16,275	—	5.0	14.0	0.0	4
5068	Lunar Base Crew Rotation (04/030)	1,800	1,800	3.0	12.0	6.0	4
5073	Geochemical Materials Lab	38,500	—	36.0	14.0	0.0	1
5075	Lunar Base Crew Logistics (04/030)	900	—	5.0	5.0	6.0	4
5082	Module Interface Mode	8,200	—	15.0	20.0	0.0	1
2004							
5010	Lunar Far UV Telescope	2,000	—	8.0	4.0	4.0	1
5018	Personnel Transfer Module (4 Man)	13,200	13,200	12.0	14.0	0.0	4
5027	Lunar Science and Field Geology	500	100	15.0	5.0	0.0	1
5029	Plant (Liquid Oxygen) (Production)	33,333	—	36.0	14.0	0.0	2
5031	Rover (Unpressurized)	4,000	—	17.0	10.0	0.0	1
5050	Lunar Lander Vehicle (Expendable)	41,660	—	13.0	14.0	0.0	6
5053	Lunar Ascent Vehicle (Expendable)	16,275	—	5.0	14.0	0.0	4
5068	Lunar Base Crew Rotation (04/030)	1,800	1,800	3.0	12.0	6.0	4

TABLE 1. (continued).

PLID	Payload Name	Descent Weight	Ascent Weight	Length	Width	Height	Units
<i>2004 continued</i>							
5074	Geochemical Materials Lab	500	—	5.0	5.0	2.0	1
5075	Lunar Base Crew Logistics (04/030)	900	—	5.0	5.0	6.0	4
<i>2005</i>							
5015	Life Science Research Facility	40,000	—	36.0	14.0	0.0	2
5018	Personnel Transfer Module (4 Man)	13,200	13,200	12.0	14.0	0.0	4
5027	Lunar Science and Field Geology	500	100	15.0	5.0	0.0	1
5036	Comm Relay (Surf) PH-2	2,500	—	15.9	10.0	0.0	1
5050	Lunar Lander Vehicle (Expendable)	41,660	—	13.0	14.0	0.0	7
5053	Lunar Ascent Vehicle (Expendable)	16,275	—	5.0	14.0	0.0	4
5065	Lunar Base Deep Drilling	4,000	—	10.0	10.0	8.0	1
5067	Lunar Base Crew Rotation (04/180)	1,800	1,800	3.0	12.0	6.0	4
5074	Geochemical Materials Lab	500	—	5.0	5.0	2.0	1
5076	Lunar Base Crew Logistics (04/180)	6,400	—	6.0	6.0	8.0	4
5079	Life Science Research Facility (Node)	8,200	—	15.0	20.0	0.0	1
5082	Module Interface Node	8,200	—	15.0	20.0	0.0	1
<i>2006</i>							
5012	Habitat Module PH-3	38,500	—	36.0	14.0	0.0	1
5014	Servicing Facility Shop Module	38,500	—	36.0	14.0	0.0	1
5018	Personnel Transfer Module (4 Man)	13,200	13,200	12.0	14.0	0.0	3
5027	Lunar Science and Field Geology	500	100	15.0	5.0	0.0	1
5062	Low Frequency Radio Array	20,000	—	50.0	20.0	10.0	1
5067	Lunar Base Crew Rotation (04/180)	1,800	1,800	3.0	12.0	6.0	3
5070	Life Science Research Facility	500	100	4.0	4.0	3.0	1
5074	Geochemical Materials Lab	500	—	5.0	5.0	2.0	1
5076	Lunar Base Crew Logistics (04/180)	6,400	—	6.0	6.0	8.0	3
5080	Lunar Lander Vehicle Logistics (LH ₂)	7,000	—	7.0	16.0		6
5054	Lunar Lander (Reusable)	11,500	—	15.0	14.0		1
5019	Personnel Transfer Module (6 Man)	7,200	—	10.0	12.0		1
<i>2007</i>							
5018	Personnel Transfer Module (4 Man)	13,200	13,200	12.0	14.0	0.0	4
5027	Lunar Science and Field Geology	500	100	15.0	5.0	0.0	1
5030	Rover (Pressurized)	38,500	—	36.0	14.0	0.0	1
5035	Comm Relay (Surf) PH-3	2,500	—	15.9	10.0	0.0	1
5061	Low Frequency Radio Array	1,000	—	4.0	4.0	4.0	1
5064	Radio Interferometry	20,000	—	32.0	14.0	0.0	1
5067	Lunar Base Crew Rotation (04/180)	1,800	1,800	3.0	12.0	6.0	4
5070	Life Science Research Facility	500	100	4.0	4.0	3.0	1
5072	Servicing Facility Shop Module	2,000	—	7.0	7.0	6.0	1
5074	Geochemical Materials Lab	500	—	5.0	5.0	2.0	1
5076	Lunar Base Crew Logistics (04/180)	6,400	—	6.0	6.0	8.0	4
5080	Lunar Lander Vehicle Logistics (LH ₂)	7,000	—	7.0	16.0		7

TABLE 1. (continued).

PLID	Payload Name	Descent Weight	Ascent Weight	Length	Width	Height	Units
2008							
5010	Lunar Far UV Telescope	2,000	—	8.0	4.0	4.0	1
5027	Lunar Science and Field Geology	500	100	15.0	5.0	0.0	1
5035	Comm Relay (Surf) PH-3	2,500	—	15.9	10.0	0.0	1
5061	Low Frequency Radio Array	1,000	—	4.0	4.0	4.0	1
5063	Radio Interferometry	1,000	—	4.0	4.0	4.0	1
5066	Lunar Base Crew Rotation (06/180)	2,700	2,700	3.0	18.0	6.0	4
5070	Life Science Research Facility	500	100	4.0	4.0	3.0	1
5072	Servicing Facility Shop Module	2,000	—	7.0	7.0	6.0	1
5074	Geochemical Materials Lab	500	—	5.0	5.0	2.0	1
5077	Lunar Base Crew Logistics (06/180)	9,600	—	8.0	8.0	10.0	4
5080	Lunar Lander Vehicle Logistics (LH ₂)	7,000	—	7.0	16.0		6
2009							
5027	Lunar Science and Field Geology	500	100	15.0	5.0	0.0	1
5033	Soil Mover/Crane/Constr. PH-3	38,500	—	36.0	14.0	0.0	1
5061	Low Frequency Radio Array	1,000	—	4.0	4.0	4.0	1
5063	Radio Interferometry	1,000	—	4.0	4.0	4.0	1
5066	Lunar Base Crew Rotation (06/180)	2,700	2,700	3.0	18.0	6.0	4
5070	Life Science Research Facility	500	100	4.0	4.0	3.0	1
5072	Servicing Facility Shop Module	2,000	—	7.0	7.0	6.0	1
5074	Geochemical Materials Lab	500	—	5.0	5.0	2.0	1
5077	Lunar Base Crew Logistics (06/180)	9,600	—	8.0	8.0	10.0	4
5080	Lunar Lander Vehicle Logistics (LH ₂)	7,000	—	7.0	16.0		7
2010							
5022	Plant (Ceramics)	38,500	—	36.0	14.0	0.0	1
5027	Lunar Science and Field Geology	500	100	15.0	5.0	0.0	1
5061	Low Frequency Radio Array	1,000	—	4.0	4.0	4.0	1
5063	Radio Interferometry	1,000	—	4.0	4.0	4.0	1
5066	Lunar Base Crew Rotation (06/180)	2,700	2,700	3.0	18.0	6.0	4
5070	Life Science Research Facility	500	100	4.0	4.0	3.0	1
5072	Servicing Facility Shop Module	2,000	—	7.0	7.0	6.0	1
5074	Geochemical Materials Lab	500	—	5.0	5.0	2.0	1
5077	Lunar Base Crew Logistics (06/180)	9,600	—	8.0	8.0	10.0	4
5080	Lunar Lander Vehicle Logistics (LH ₂)	7,000	—	7.0	16.0		6

more payload would have to be carried each flight. This factor presented several possibilities for transporting the payloads. Three options were chosen for this paper. The first was to use the number of flights outlined in the CNDB. This would serve as a baseline. The second would be to use the minimum number of flights. And finally, the third would have no limit on the number of flights.

The number of flights used in the CNDB is implied by the number of descent and ascent stages (payload I.D.s 5050 and 5053) listed for each year through 2005 and by the number of

lunar lander logistics (liquid hydrogen) deliveries (payload I.D. 5080) for each year after that. The CNDB uses the assumption that once lunar-produced liquid oxygen is available (by 2006), a reusable lunar lander would perform all payload deliveries. The number of flights used for the baseline option in this paper uses the same vehicle assumptions as the CNDB except for two modifications. The first is that rather than use the reusable lander for all flights after 2005, an expendable lander would be used for the unmanned payload delivery missions. This would reduce the payload requirement for the reusable lander by 43%. The

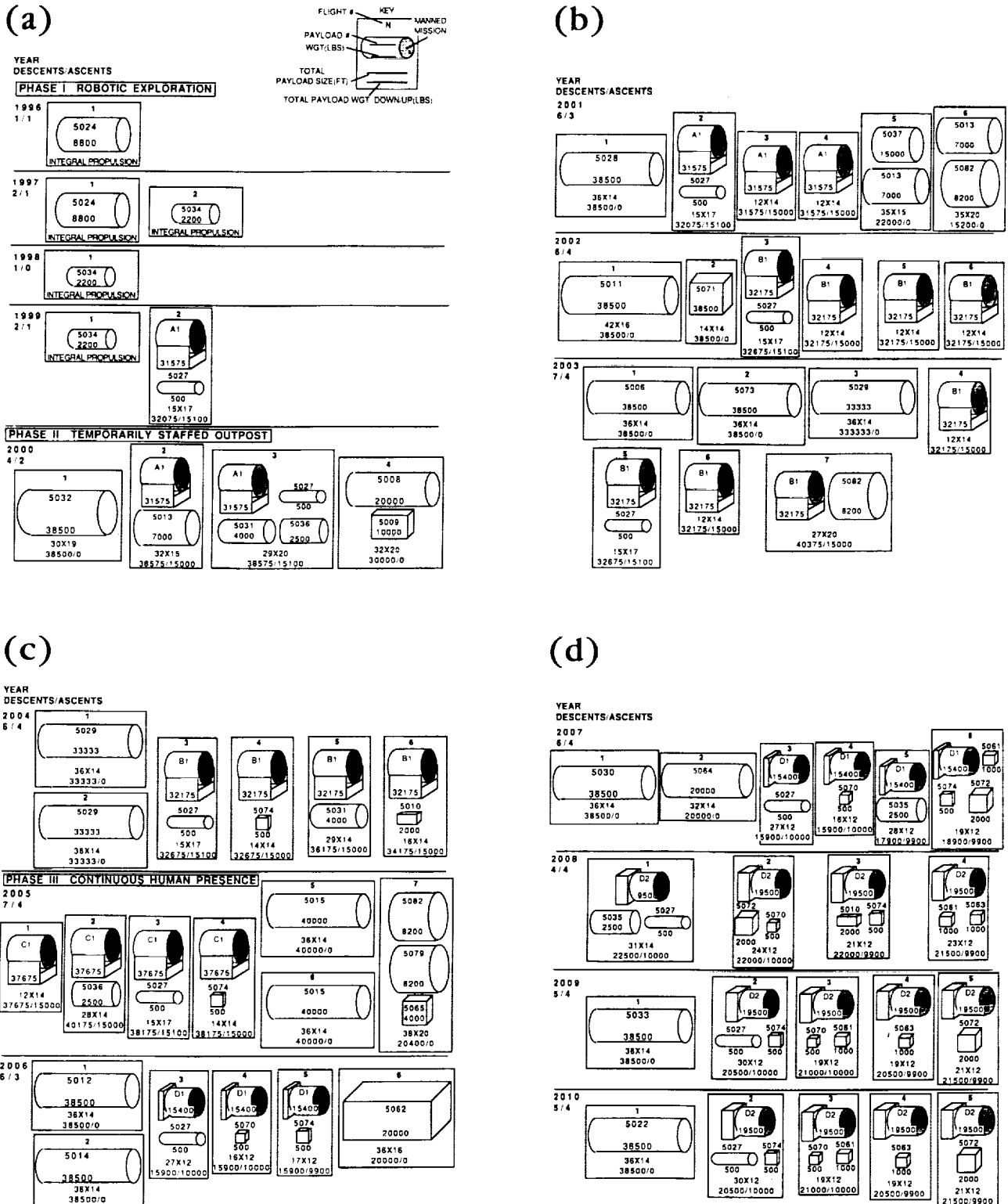

Fig. 4. CNDB lunar payloads: option 1. (a) 1996-2000; (b) 2001-2003; (c) 2004-2006; and (d) 2007-2010. Special payload combinations are

PLID	Payloads included	Wt.
A1	5018, 5002, 5052, 5053	31575
B1	5018, 5068, 5075, 5053	32175
C1	5018, 5067, 5076, 5053	37675
D1	5019, 5067, 5076	15400
D2	5019, 5066, 5077	19500

other modification to the CNDB assumptions was to eliminate some of the flights between 2007 and 2010. This would result in a more efficient use of the reusable lander.

The lunar payloads for each year in the CNDB are depicted in Fig. 4. They are drawn to scale, based on the dimensions given in Table 1. Within each year, the payloads are divided into groups representing each flight necessary for option 1. The groups were arranged in such a way as to keep the payload weight and size to a minimum for each flight. The total payload size represents the smallest cargo pad area that would be occupied by the payloads for that particular flight. The data contained in Fig. 4 were used to determine several requirements for the lunar lander stages.

The first requirement for the landers that was found was the maximum payload weight for each of the landers. These requirements can be seen in Fig. 5, which summarizes the payload carrying requirements for option 1. This figure shows that the maximum descent payload weight for the expendable lander is about 41,000 lb and for the reusable lander is 23,000 lb. Figure 4 was also used to determine several other stage requirements. The maximum payload for the expendable ascent vehicle is 15,100 lb and the maximum ascent payload for the reusable lander is 10,000 lb. In addition to payload weight requirements, payload size requirements were found. The maximum payload size for the expendable lander was 42 × 20 ft, for the expendable ascent vehicle it was 12 × 14 ft, and for the reusable lander it was 31 ×

14 ft. The final requirements determined from Fig. 4 were the number of trips and the number of vehicles required during the period 1996 to 2010. There are 63 descents and 41 ascents required for option 1. The vehicle requirements for option 1 are 44 expendable landers, 22 expendable ascent vehicles, and at least 1 reusable lander for a total of 67 vehicles.

The second flight option that was considered minimized the number of flights. For this option, it was assumed that after initial robotic exploration, there would be flights to the Moon only when it was necessary to send a crew. For this option, the number of flights corresponds to the number of manned missions listed in the CNDB. All the payloads would be transported on these flights. Also, all flights after 2005 would use a reusable lander as was originally assumed in the CNDB. Figure 6 shows the CNDB lunar payloads grouped by year and flight number for option 2. Since there are fewer flights, more payload must be carried on each flight. The payload carrying requirements for option 2 are summarized in Fig. 7. It can be seen that the maximum descent payload for the expendable lander is approximately 78,000 lb and for the reusable lander is 58,000 lb. Figure 6 was also used to determine other requirements. The maximum ascent payload for the expendable ascent vehicle was found to be 15,000 lb and for the reusable lander, 10,000 lb. The payload sizes were found to be 42 × 30 ft for the expendable lander, 12 × 14 ft for the expendable ascent vehicle, and 36 × 28 ft for the reusable lander. There are 41 descents and 41 ascents required for this option. Finally,

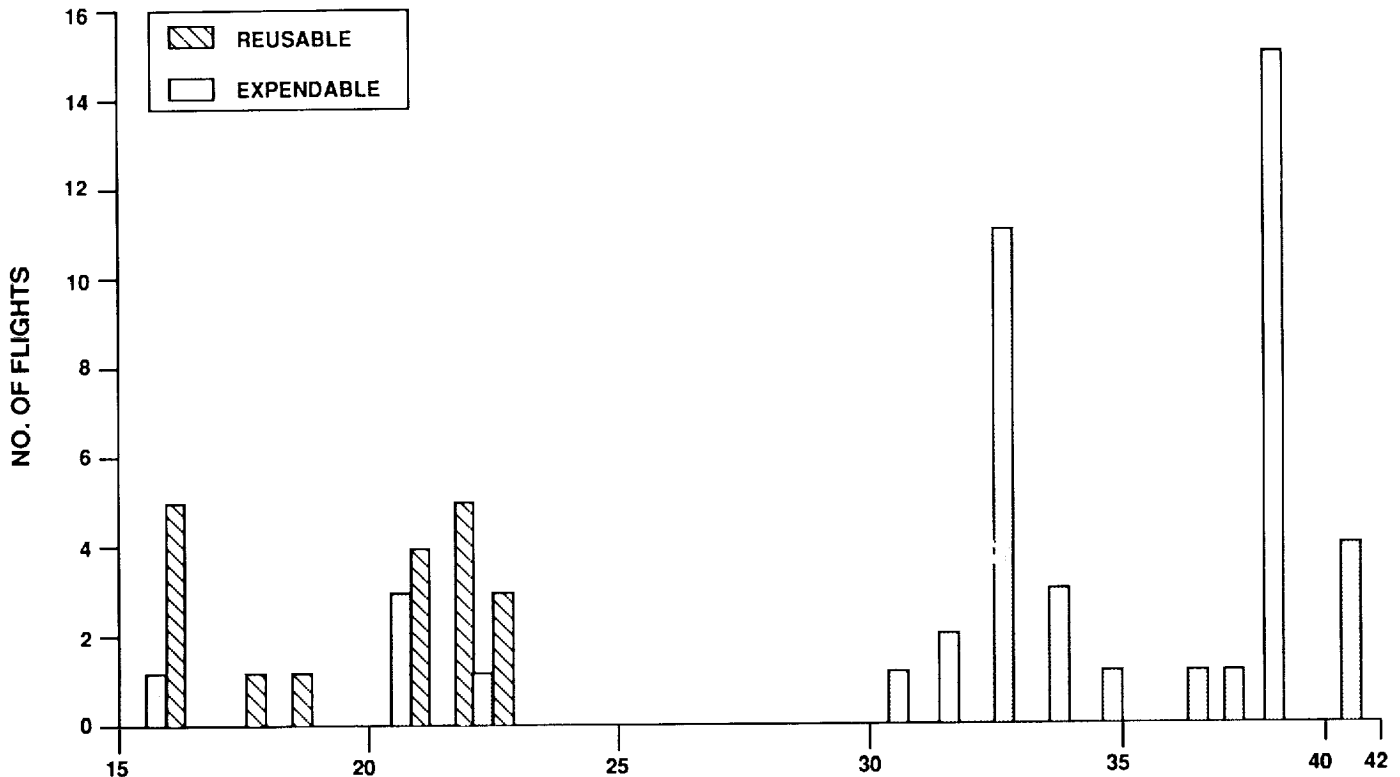

Fig. 5. Number of lunar lander flights required for various payload weights in option 1.

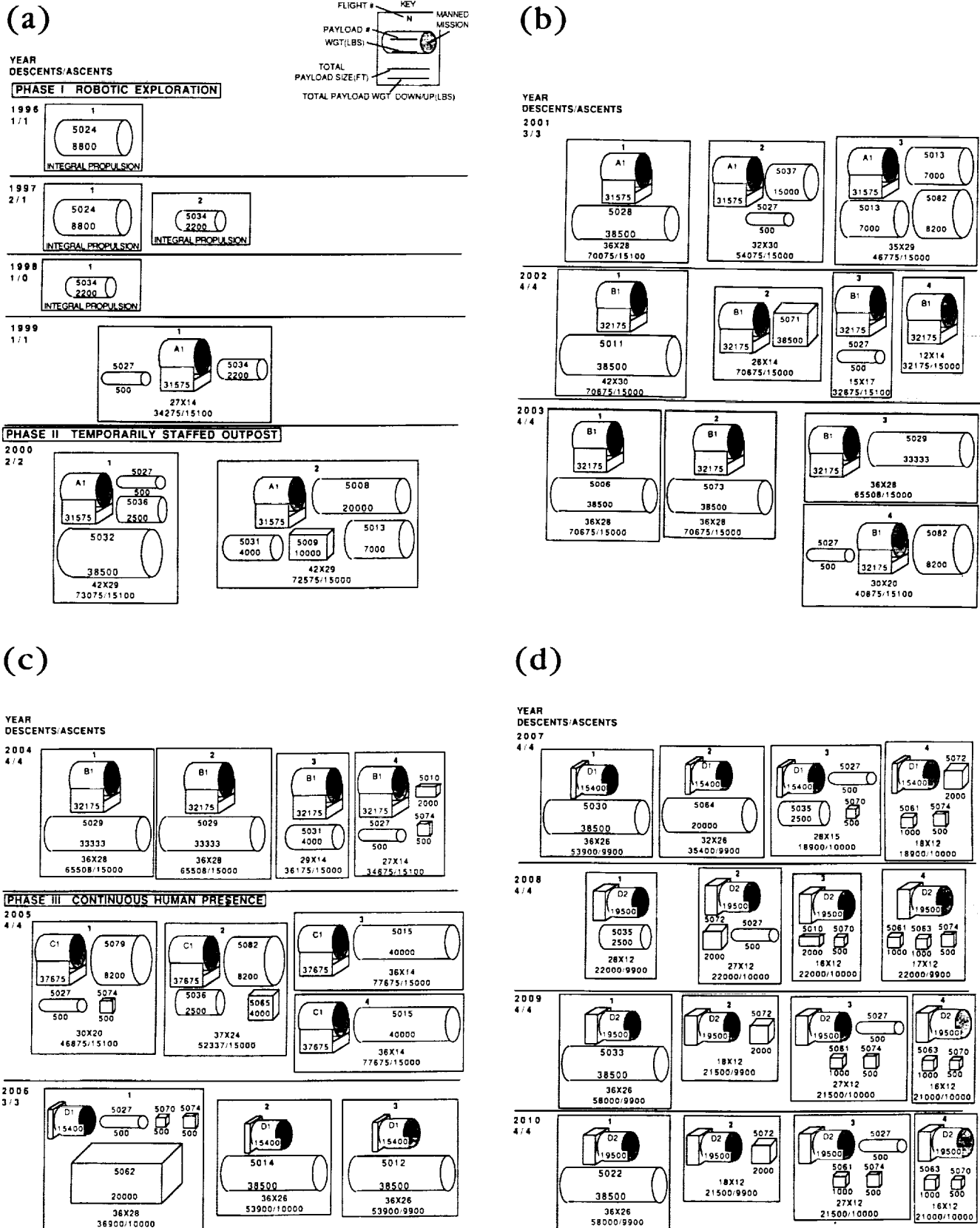

Fig. 6. CNDB lunar payloads: option 2. (a) 1996-2000; (b) 2001-2003; (c) 2004-2006; and (d) 2007-2010. Special payload combinations as shown in Fig. 4.

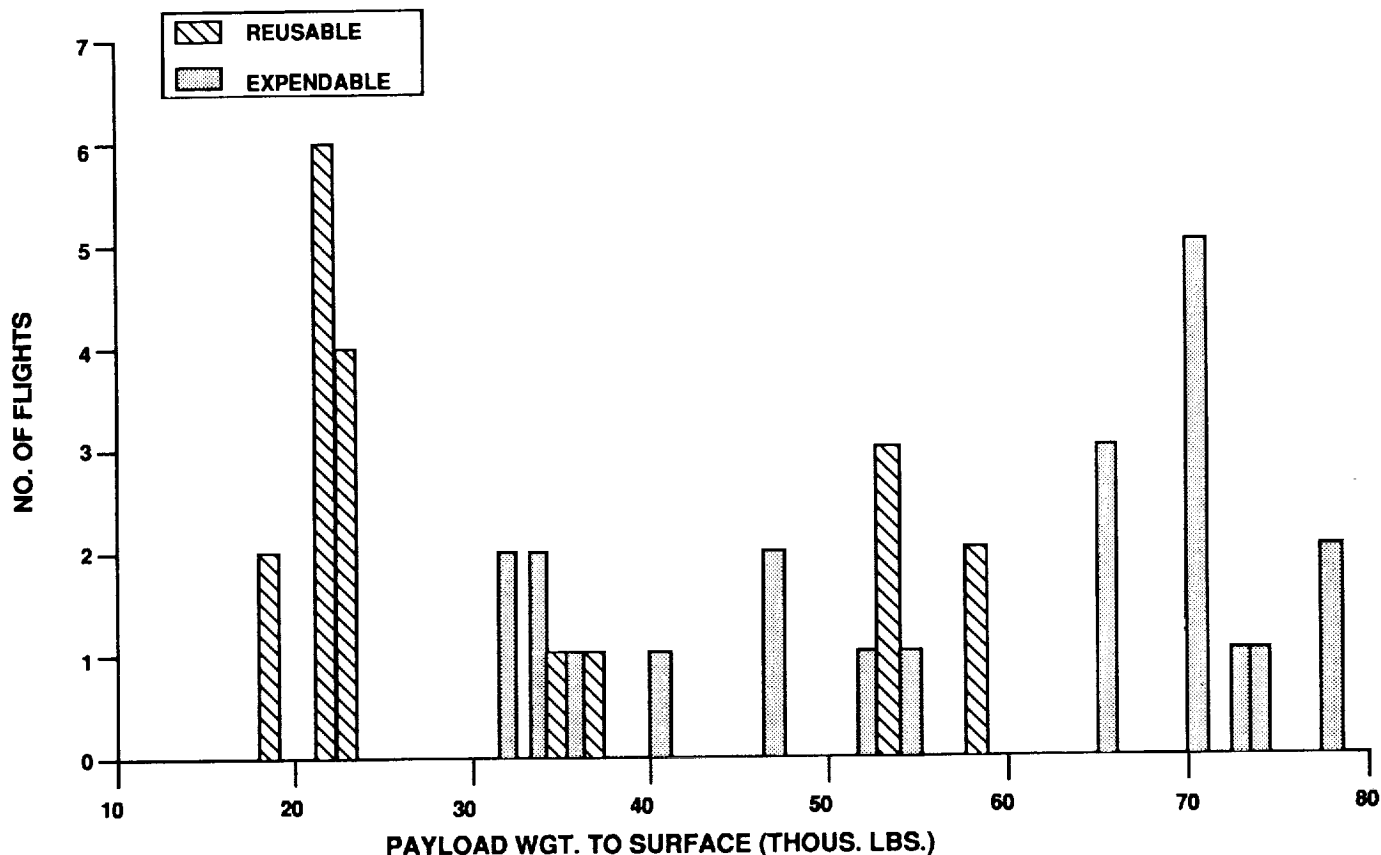

Fig. 7. Number of lunar lander flights required for various payload weights in option 2.

there are 22 expendable landers, 22 expendable ascent vehicles, and at least 1 reusable lander required. The total number of vehicles for option 2 is 45.

The final payload delivery option identified lunar lander requirements if there were no limit on the number of trips to the lunar surface. The key assumption for this option was that every payload weighing more than 500 lb would land on the Moon separately. Payloads weighing up to 500 lb would be transported on manned missions since they usually represent some experiment conducted by the crew. Figure 8 shows the payloads for each flight for each year. It is obvious that using one type of vehicle to transport both 40,000-lb payloads and 1000-lb payloads would not be efficient. Therefore, multiple vehicles were considered, each one designed to carry a specific range of payload weights.

The number of types of vehicles and the payload ranges for each of the stages was found by looking at the overall range of payload carrying requirements shown in Fig. 9. The conclusions that were drawn indicated that two sizes of expendable landers are required and that two sizes of reusable landers are required. A total of 39 expendable landers with a payload capability of 20,000 to 41,000 lb with a payload size of 36 × 19 ft are required. Fifteen

expendable landers for payloads under 16,000 lb and 30 × 15 ft in size are required. The first reusable lander would have a descent payload requirement of 20,000 lb and an ascent payload of 10,000 lb. The largest payload size would be 36 × 17 ft. The second reusable lander would have a descent payload of just 3500 lb and no ascent payload requirement. The stage size would be influenced more by the size of the propellant tanks than the payloads. The expendable ascent vehicle requirements were identical to the first two options. For this option, there would be 89 descents to the surface and 57 ascents. A total of at least 78 vehicles would be required.

All the lander requirements determined up to this point were imposed by the payloads. In order to determine other requirements related to the propulsion system or stage weight, it was necessary to develop a conceptual design for the lunar lander stages. First, the propulsion requirements were determined, then the stage weight was evaluated. This information led to the development of a scaling equation for the lander stages.

The descent and ascent trajectories were assumed to be very similar to those used during the Apollo Program (Alphin et al. 1968; Bellcom Inc., 1968; Martin Marietta, 1987). An initial thrust-to-weight ratio of 0.6 was assumed for both descent and

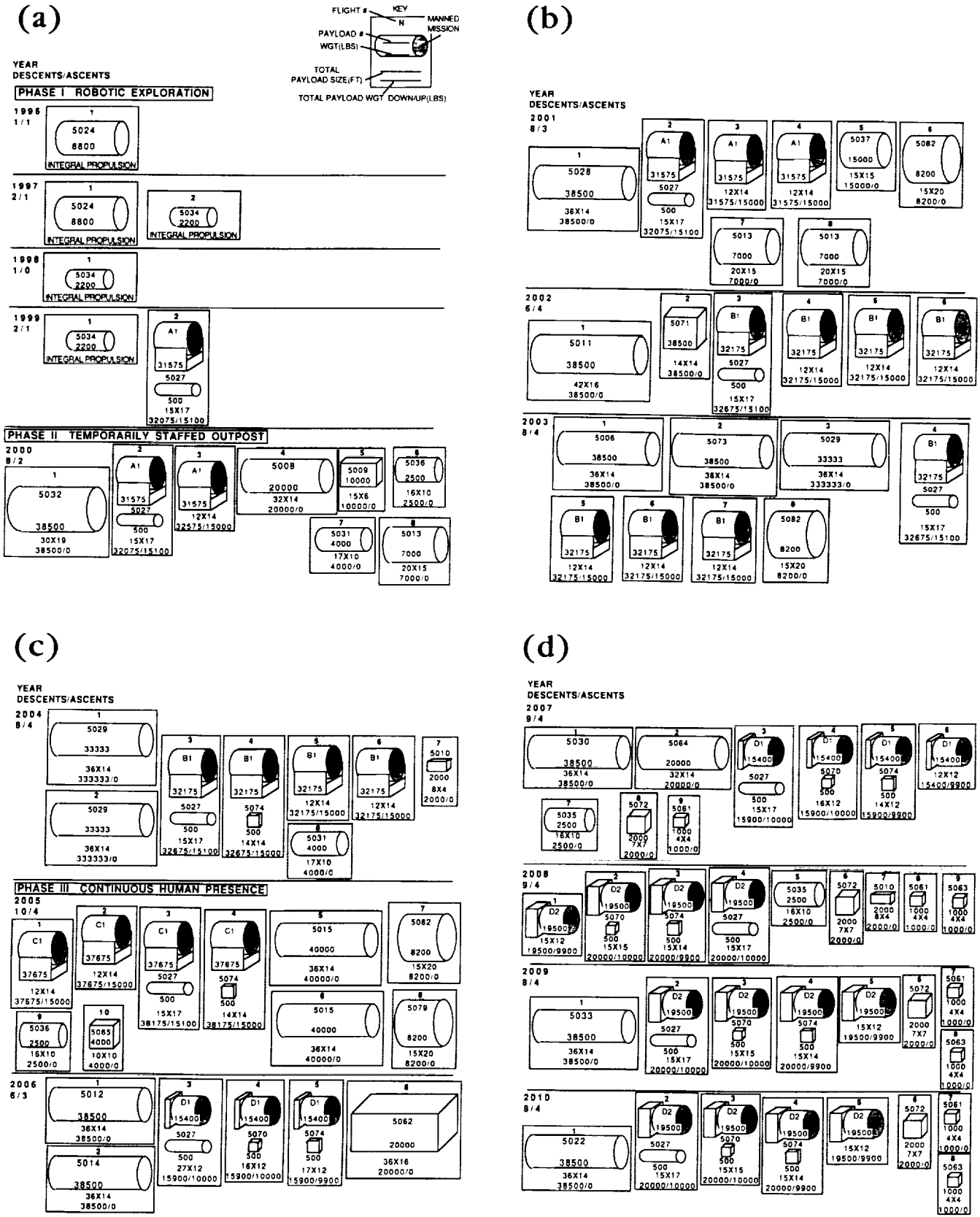

Fig. 8. CNDB lunar payloads: option 3. (a) 1996-2000; (b) 2001-2003; (c) 2004-2006; and (d) 2007-2010. Special payload combinations as shown in Fig. 4.

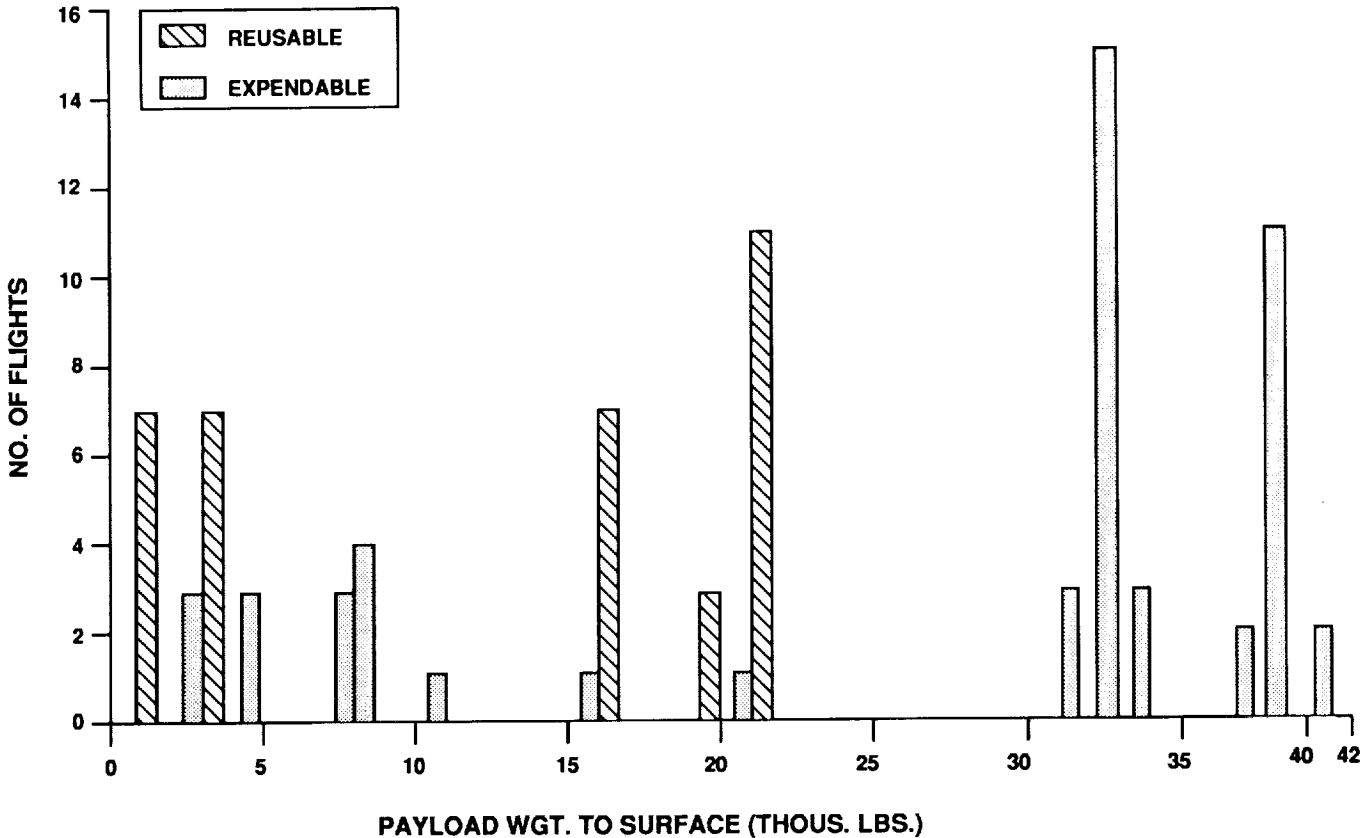

Fig. 9. Number of lunar lander flights required for various payload weights in option 3.

ascent (Laidlaw, 1964, pp. 16-17). This determines the maximum thrust required for the lander. In addition to providing this maximum thrust, the lander engines must be throttlable for two reasons. The first is due to the assumed configuration of the stage. In determining the payload sizes for the previous options, it was assumed that the payloads would be arranged on a rectangular platform. Four engines would be placed at the corners of the platform. This configuration would have limited engine-out capability if the remaining three engines and the attitude control system could maintain proper vehicle balance. Since it would not always be possible to balance the payloads around the center of the platform, the engine thrusts would have to be biased to compensate for any center-of-gravity offsets. Figure 10 shows how much the engines would have to be throttled to compensate for center-of-gravity offsets. In addition to this throttling requirement, the stage must have an overall throttle ratio of 21:1 during the descent trajectory (Martin Marietta, 1987, p. 49).

The ΔVs chosen for this paper were 2195 M/S for descent (Martin Marietta, 1987, p. 133) and 1920 M/S for ascent (Eagle Engineering, 1984, p. 24). The initial calculations for stage propellant requirements were based on these ΔVs and the following scaling equation (Eagle Engineering, 1984, p. 25)

$$W_1 = 5024 + 0.04545 W_p$$

where W_1 = stage inert weight (lb) and W_p = propellant weight (lb). This scaling equation was substituted into the rocket

equation to give the following equation for propellant weight as a function of ΔV and payload weight

$$W_p = \frac{(E-1)(5024 + W_{pl})}{0.04545(1-E) + 1}$$

where

$$W_{pl} = \text{payload weight (lb)}$$

and

$$E = e^{\left(\frac{\Delta V}{gI_{sp}}\right)}$$

The initial propellant requirements were used to size the propellant tanks for the lander stages.

The propulsion system requirements for each vehicle and option are summarized in Table 2. The propulsion system was based on the use of RL10 engines. The required average thrust per engine to achieve an initial thrust-to-weight ratio of 0.6 is shown in this table. The actual thrust per engine would vary depending on the requirement to compensate for a center-of-gravity offset. The propellant tanks were sized so they would fit within the same area as the payloads. The arrangement of the engines and tank for the landers and ascent vehicles is shown in Figs. 11a,b. The middle portion of the payload platform on expendable landers was left open to allow room for the ascent vehicle as shown in Fig. 11c.

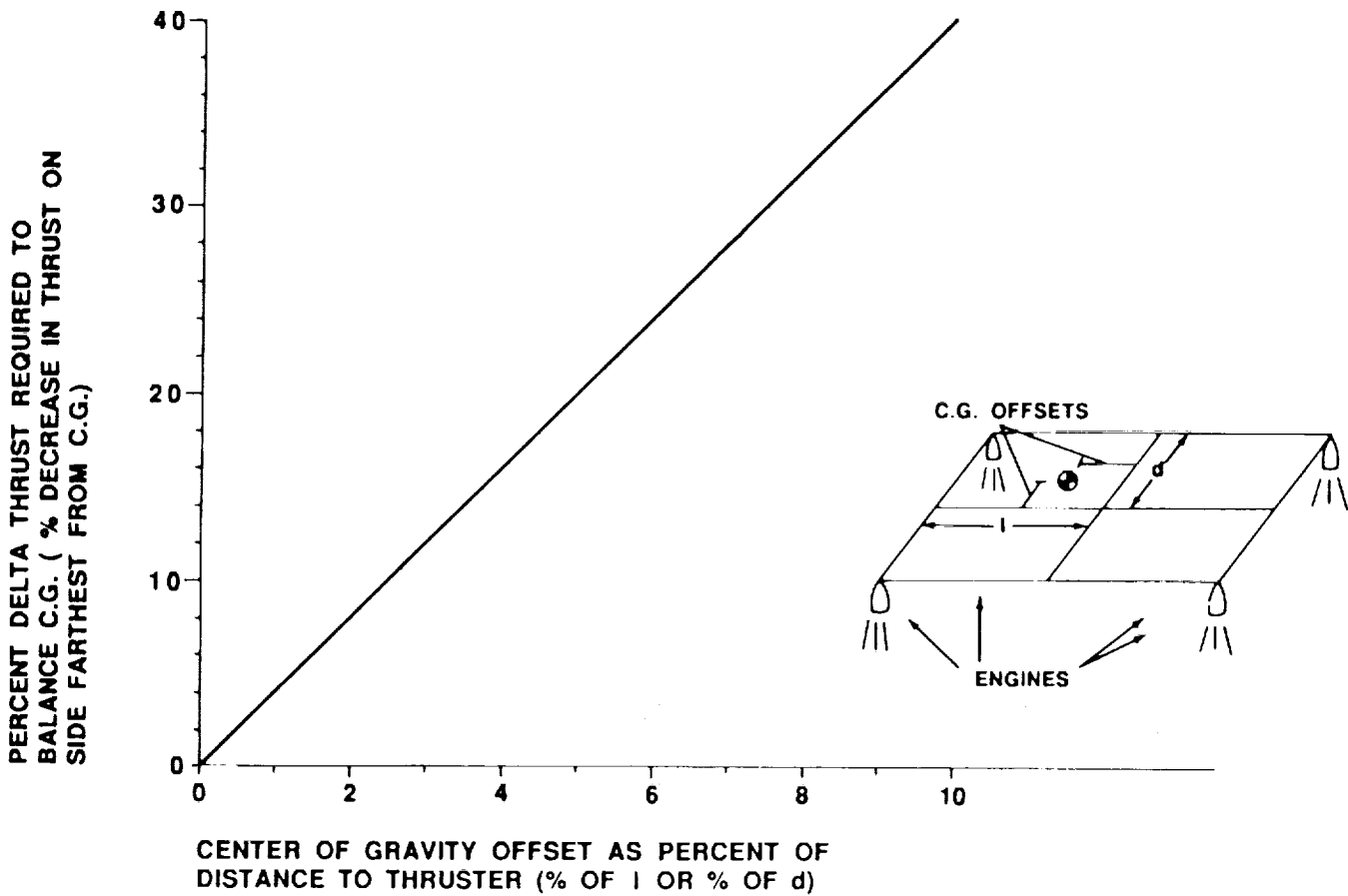

Fig. 10. Throttability required to balance center-of-gravity offsets.

TABLE 2. Lunar lander vehicle propulsion system summary.

	Option 1, 2, & 3	Option 1		Option 2		Option 3			
	Expendable Ascent Veh.	Expendable Lander	Reusable Lander	Expendable Lander	Reusable Lander	Expendable Lander 1	Expendable Lander 2	Reusable Lander 1	Reusable Lander 2
Engine Type	RL10-IIIB	RL10-IIIB	RL10-IIIB	RL10-IIIB	RL10-IIIB	RL10-IIIB	RL10-III	RL10-IIIB	RL10-III
Number of Engines	2	4	4	4	4	4	4	4	2
Thrust per Engine (lb)	9233	12679	10524	23286	21702	12530	5430	10061	4986
LOX Tank Size (ea.)	5.1 × 5.1	7.9 × 6	7.9 × 6.7	22.3 × 4.6	21.8 × 4.7	11.2 × 5	7.9 × 4	7.1 ×	7.1
LH ₂ Tank Size (ea.)	9.5 × 6.3	17.8 × 7	13.6 × 8.8	29.8 × 7.2	27.9 × 7.5	19.5 × 6.7	14.9 × 5.1	16.7 × 7.4	10.7 × 5.3
LOX Tank Weight (lb ea.)	79	246	246	596	600	275	116	220	68
LH ₂ Tank Weight (lb ea.)	276	800	785	1521	1532	805	357	799	248
Total Tank Weight (lb)	710	2092	2062	4234	4264	2160	946	2038	632
Total Engine Weight (lb)	784	1568	1568	1568	1568	1568	1504	1568	752
Propulsion System Weight (lb)	1494	3660	3630	5803	5832	3728	2450	3606	1384

All stages have two pairs of tanks.

Engines:	RL10-IIIB:	RL10-III:
	Isp = 460 (sec)	Isp = 462 (sec)
	Thrust = 15,000 (lb)	Thrust = 7500 (lb)
	Mixture Ratio = 6:1	Mixture Ratio = 6:1
	Weight = 392 (lb)	Weight = 376 (lb)
	Size = 5 × 6 × 6 (ft)	Size = 5 × 5 × 5 (ft)

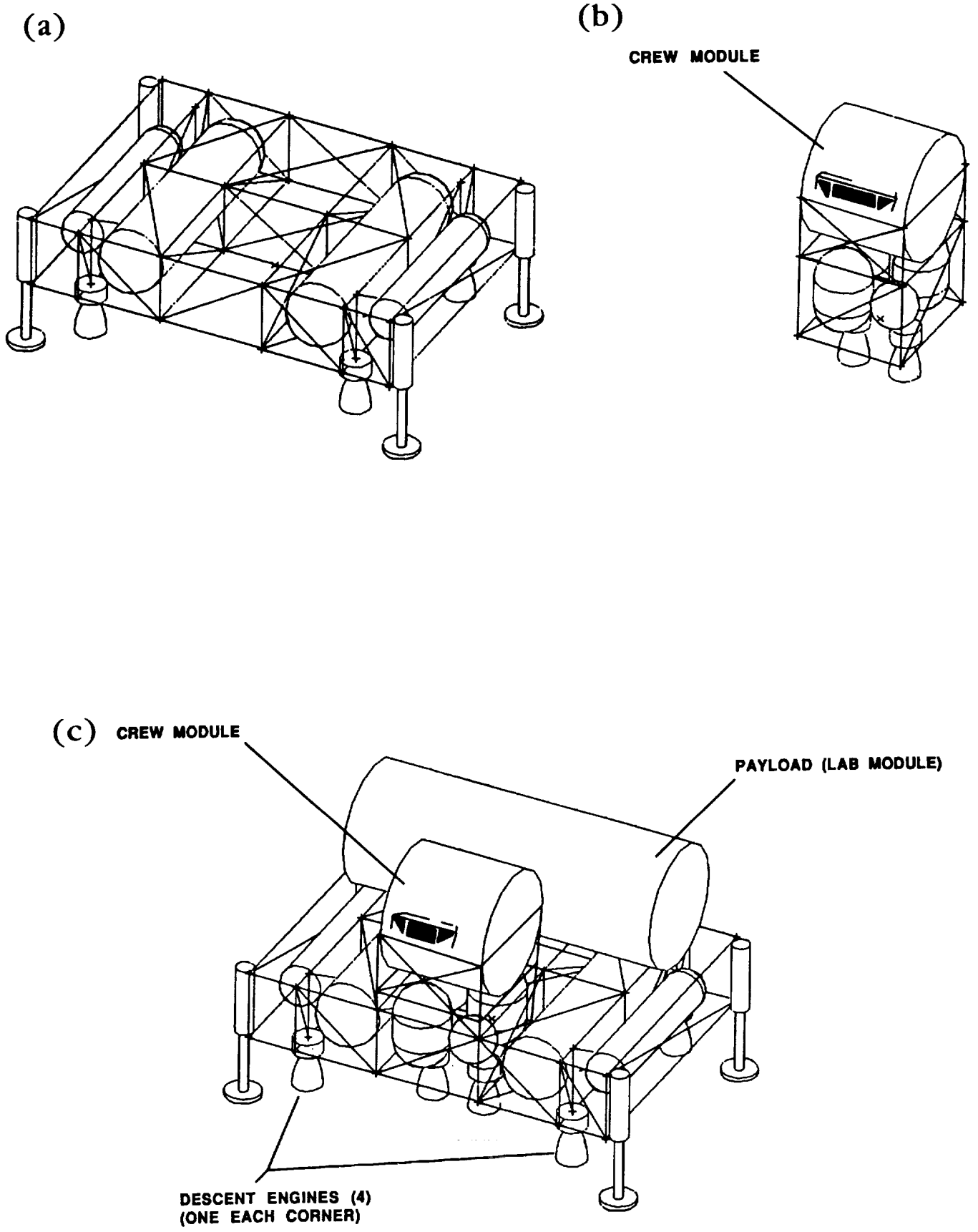

Fig. 11. Lander stage configuration. (a) descent stage (expendable or reusable); (b) ascent stage (expendable); and (c) descent stage with ascent stage plus payload.

TABLE 4. Lunar lander vehicle cost summary (1988 dollars in millions).

	Option 1, 2, & 3	Option 1		Option 2		Option 3			
	Expendable Ascent Veh.	Expendable Lander	Reusable Lander	Expendable Lander	Reusable Lander	Expendable Lander 1	Expendable Lander 2	Reusable Lander 1	Reusable Lander 2
DDT&E									
Stage	2723	4,191	5886	5,331	7743	4,144	3177	5908	4117
Engine	493	493	740	483	725	493	493	740	725
Total	3216	4,684	6626	5,814	8468	4,637	3670	6648	4842
First Unit Cost									
Stage	190	347	396	486	581	342	236	398	240
Engine	7	13	16	13	8	13	13	16	8
Total	197	360	412	499	589	355	249	414	248
Total Production Cost of Vehicles	3127	10,374	412	7,921	589	9,224	2837	414	248
Total Operations Cost	220	440	190	220	190	390	150	210	140
Total Life Cycle Cost	6563	15,498	7228	13,955	9247	14,251	6657	7272	5230
Total Cost of Option		29,289		29,765		39,973			

Note: These costs do not include transportation to low-Earth orbit or lunar orbit.

that the process of determining lunar lander requirements described in this paper will be useful in the future as program scenarios and payload models change.

REFERENCES

- Alphin J. H., Taylor B. G., and Kirkland B. G. (1968) *LM Powered Descent Trajectory for the Apollo Lunar Landing Mission*. NASA-TM-X-69804, NASA Manned Spacecraft Center (Johnson Space Center), Houston. 10 pp.
- Battelle Columbus Division (1987) *Advanced Space Transportation System Mission Analysis Final Report* for NASA Johnson Space Center. Contract No. NAS9-17356, Columbus. 278 pp.
- Bellcom Inc. (1968) *LM Landing Using Steep Descent Trajectory*, TM-682015-1, NASA Contract No. NASAF-CR-95562, Washington, DC. 10 pp.
- Eagle Engineering (1984) *Impact of Lunar and Planetary Missions on the Space Station Final Report*. Report 84-85D for NASA Johnson Space Center, pp. 4, 24-26. Contract No. NAS9-17176.
- JSC (Johnson Space Center) (1984) *Lunar Surface Return*, Internal Report 84-00637, p. D7.
- Laidlaw W. R. (1964) The characteristics of lunar missions. In *Lunar Missions and Exploration* (C. T. Leondes and R. W. Vance, eds.), pp. 16-17. Wiley, New York.
- Martin Marietta (1987) *Orbital Transfer Vehicle Concept Definition and System Analysis Study Contract Extension II Final Review*, MCR-87-2600, for NASA Marshall Space Flight Center, Contract No. NAS8-36108, Denver. 441 pp.
- McCauley L. A. (1986) *National Space Transportation and Support Study Civil Needs Data Base Version 1.1 Summary Report*, Vol. I, pp. i, 4-1, 4-2. Washington, D.C.
- Woodcock G. R. (1985) Mission and operations modes for lunar basing. In *Lunar Bases and Space Activities of the 21st Century* (W. W. Mendell, ed.), pp. 111-124. Lunar and Planetary Institute, Houston.