

PRECEDING PAGE BLANK NOT FILMED

# LUNAR LANDER CONCEPTUAL DESIGN

J. M. Stecklein and A. J. Petro

Mail Code ED231  
NASA Johnson Space Center  
Houston TX 77058

N 9 3 - 1 7 4 2 8

W. R. Stump, A. S. Adorjan, T. V. Chambers,  
M. D'Onofrio, J. K. Hirasaki, O. G. Morris,  
G. Nudd, R. P. Rawlings, C. C. Varner,  
C. W. Yodzis, and S. J. Zimprich

Eagle Engineering  
16915 El Camino Real, Suite 200  
Houston TX 77058

*This paper is a first look at the problems of building a lunar lander to support a small lunar surface base. A series of trade studies was performed to define the lander. The initial trades concerned choosing number of stages, payload mass, parking orbit altitude, and propellant type. Other important trades and issues included plane change capability, propellant loading and maintenance location, and reusability considerations. Given a rough baseline, the systems were then reviewed. A conceptual design was then produced. The process was carried through only one iteration. Many more iterations are needed. A transportation system using reusable, aerobraked orbital transfer vehicles (OTVs) is assumed. These OTVs are assumed to be based and maintained at a low Earth orbit (LEO) space station, optimized for transportation functions. Single- and two-stage OTV stacks are considered. The OTVs make the translunar injection (TLI), lunar orbit insertion (LOI), and trans-Earth injection (TEI) burns, as well as midcourse and perigee raise maneuvers.*

## INTRODUCTION

This paper summarizes work carried out under NASA contract and documented in more detail in the Lunar Lander Conceptual Design (Eagle Engineering, 1988). One lander, which can land 25,000 kg, one way, or take a 6000-kg crew capsule up and down is proposed. The initial idea was to build a space-maintainable, single-stage, reusable lander suitable for minimizing the transportation cost to a permanent base, and use it from the first manned mission on. Taking some penalty and perhaps expending expensive vehicles early in the program would avoid building multiple types of landers.

A single-stage lander is feasible from low lunar orbit (LLO) (less than 1000 km). The single-stage lander will be heavier (15-30%) in LLO than a two-stage vehicle. A lander capable of multiple roles, such as landing cargo one way or taking crew modules round-trip, is possible with some penalty (5-10%) over dedicated designs; however, the size of payload delivered to lunar orbit may vary by a factor of 2.

A four-engine design for a multipurpose vehicle, with total thrust in the range of 35-40,000 lbf (12,000 to 13,000 lbf per engine) and a throttling ratio in the 13:1 to 20:1 range is proposed. Initial work indicates a regeneratively cooled, pump-fed engine will be required due to difficulties with regenerative cooling over wide throttling ranges with pressure-fed systems. The engine is the single most important technical development item. Reuse and space maintainability requirements make it near or beyond the current state of the art. Study and simulation work should continue until this engine is defined well enough for long lead development to start.

The lander must be designed from the start for simplicity and ease of maintenance. Design features such as special pressurized

volumes will be needed to make the vehicle maintainable in space. Space maintainability and reusability must be made a priority.

Liquid oxygen/liquid hydrogen (LOX/LH<sub>2</sub>) propellants show the best performance, but LH<sub>2</sub> may be difficult to store for long periods in the lander on the surface. Earth-storable and space-storable propellants are not ruled out. Liquid hydrogen storage over a 180-day period on the lunar surface at the equator needs study. A point design of a LOX/LH<sub>2</sub> lander needs to be done in order to have a good inert mass data point that shows the performance gain is real.

Initial calculations indicate LLO offers the lowest low-Earth-orbit (LEO) stack mass. Low-altitude lunar orbits are unstable for long periods. The instability limit may set the parking orbit altitude.

Low-Earth-orbit basing for the lander is possible with some penalty in LEO stack mass (10-25%) over a scheme that bases the lander in LLO or expends it. The lander will require a special orbital transfer vehicle (OTV) to aerobrake it into LEO, however. Figure 1 shows a conceptual design of a LOX/LH<sub>2</sub> lander and a large OTV that carries it, single stage, from LEO to LLO and back.

## SCALING EQUATIONS

It is difficult to accurately estimate the inert mass of the lander, which is a key issue in several of the trades. An equation was developed to scale the lander so that it matches the Apollo lunar module (LM) at one point, and accounts for different payloads and propellants. The LM provides the best historical data point from which scaling equations can be formulated.

On a lunar lander some systems, such as overall structure, vary with the gross or deorbit mass ( $M_g$ ). Others, such as tanks, are primarily dependent on propellant mass ( $M_p$ ). Other systems,

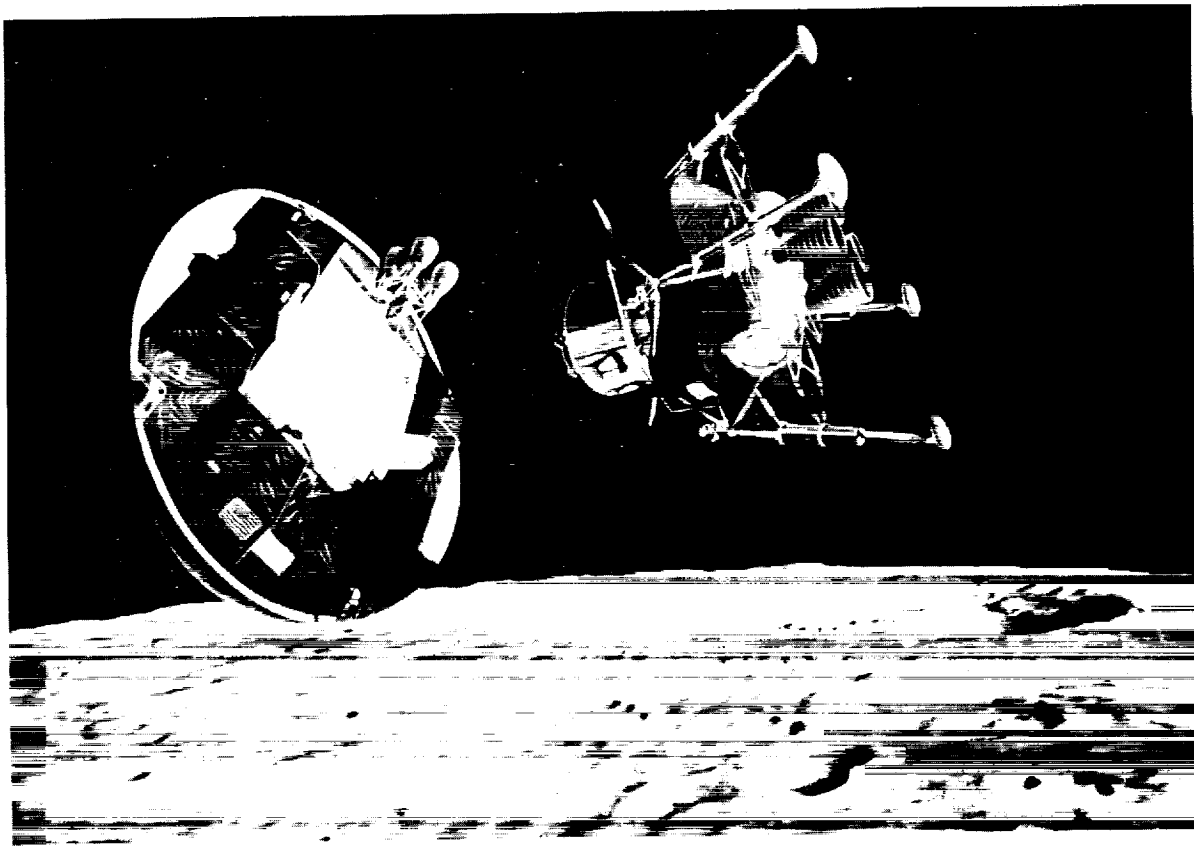

Fig. 1. OTV and lander in lunar orbit.

such as the computers, will change very little or not at all with the lander size. The inert mass ( $M_i$ ), which is the sum of all of these systems, can therefore be represented using equation (1)

$$M_i = CM_g + BM_p + A \quad (1)$$

To compare vehicles using cryogenic propellant systems with vehicles using storable propellant systems, the equation needs further modification. Due to the typically high volume associated with cryogenic propellants, it is expected that the tank systems and the thermal protection systems will be larger than for storable propellants of the same mass. Equation (1) does not take such effects into account.

One solution is to make the second term of the equation a function of the propellant bulk density ( $D_b$ ). The bulk density is the total mass of propellants divided by the total volume of propellant. The tank inert mass is inversely related to the bulk density, therefore the equation should be rewritten as

$$M_i = CM_g + BM_p/D_b + A \text{ (Linear Law)} \quad (2)$$

$M_p/D_b$  is the total volume of propellant. This equation is a linear scaling function and assumes that those systems that are dependent on the propellant, or bulk density, are scaled linearly with propellant mass or volume.

The coefficients of the linear scaling law in equation (2) are determined by matching the masses calculated from the law with those of the Apollo LM for its various subsystems. The LM ascent

stage is taken as a model payload. The coefficients of the scaling equation can be found and equation (2) becomes

$$M_i = 0.0640 M_g + 0.0506 (1168/D_b) M_p + 390 \text{ <kg>} \quad (3)$$

	Propellant lbm/ft <sup>3</sup>	Bulk Density kgm/m <sup>3</sup>	Mixture Ratio	Isp lbf-sec/lbm
N <sub>2</sub> O <sub>4</sub> /Aer 50	72.83	1168	1.6:1	300
N <sub>2</sub> O <sub>4</sub> /MMH	73.17	1170	1.9:1	330
LO <sub>2</sub> /LH <sub>2</sub>	22.54	361	6:1	450

### TWO-STAGE VS. SINGLE-STAGE

The LM true payload was calculated to be 2068 kg. A single-stage vehicle, scaled using the above equation, transporting 2068 kg to and from the lunar surface to a 93-km circular orbit must have a gross mass in orbit, prior to descent, of 21,824 kg. When ascent and descent stages are used, applying the derived scaling equations, and assuming that the descent payload is equal to the ascent gross mass, the total gross mass of the two-stage lander prior to descent from orbit is 18,903 kg. The real LM, which is not an entirely equivalent case, had a mass of 16,285 kg.

As expected, single-stage to and from LLO results in some penalty. This penalty must be weighed against the benefits of single-stage operations, the chief one being easy reusability. Other

benefits include reduced development cost and greater simplicity. Total reusability is not practical without single-stage operation. Once lunar surface oxygen becomes available, the performance losses associated with single-stage operation will go away and single-stage operation will be the preferred mode. Single-stage operation is therefore chosen as the baseline.

### SINGLE-STAGE PERFORMANCE PLOTS

Figures 2, 3, and 4 show the lander performance to and from a 93-km orbit using different propellants. The three propellants/mixture ratios/Isp as shown in the above chart are used. The Isp are chosen to be average values for a lunar ascent/descent.

The plots show three cases. In the "Cargo Down" case, the lander does not have propellant to ascend to orbit after delivering its payload. All the propellant capacity is used to deliver a large payload to the surface. The case in which the lander places a

payload on the surface and has enough propellant remaining to return its inert mass to orbit is called the "Inert Returned" case. In the "Crew Module Round Trip" case a crew module is taken down to the surface and then back to orbit.

Tables 1 and 2 show performance vs. Isp as well as other variables. The cryogenic vehicle shows better performance, but not as much as expected. The low density of hydrogen drives the propellant mass multiplier up in the scaling equation (3). The equations may be biased against a pump-fed cryogenic system because they are scaled from a pressure-fed storable system.

### PARKING ORBIT ALTITUDE

Tables 1 and 2 show how lander mass increases steadily as lunar orbital altitude goes up. Table 3 shows how LEO stack mass also goes up with lunar orbit altitude. The LEO stack mass does not rise dramatically until orbits of 1000 km or over are used. From a performance standpoint, the lowest orbits are therefore preferable. Apollo experience has indicated that very low orbits, on the order of 100 km, may be unstable over periods of months. The best altitude will therefore be the lowest altitude that is stable for the period required.

Ascent to a 93-km lunar orbit is assumed to be 1.85 km/sec. Descent from a 93-km lunar orbit is assumed to be 2.10 km/sec. These values were back-calculated from the Apollo 17 weight statement in order to match design theoretical values. They closely match postmission reported Apollo 11  $\Delta V$ s of 2.14 and 1.85 km/sec (*Apollo 11 Mission Report*, 1969). Ascent/descent to or from higher lunar orbits assumed a Hohmann transfer.

### PLANE CHANGE CAPABILITY

One-time plane changes on the order of 15° in low lunar circular orbit can be built in for modest lander mass increases on the order of 10% for LOX/LH<sub>2</sub> landers. This will also result in a LEO stack mass increase of at least 10%. The plane change  $\Delta V$  and vehicle mass increase does not vary much with lunar orbit altitudes below 1000 km for a given angle of plane change;

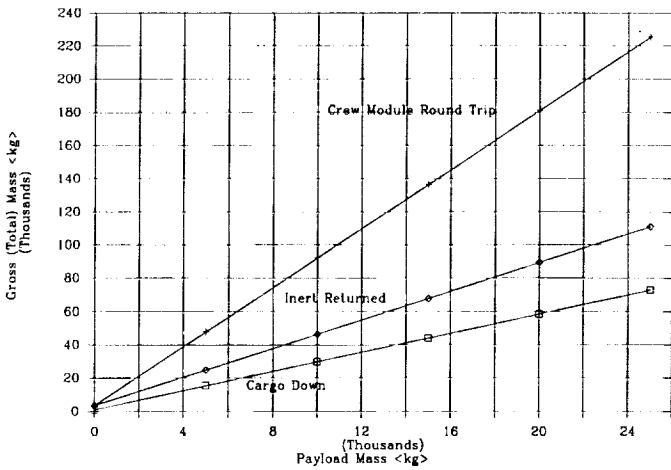

Fig. 2. Single-stage crew/cargo lander. Orbit = 93 km; MR = 1.6 N/A; Isp = 300.

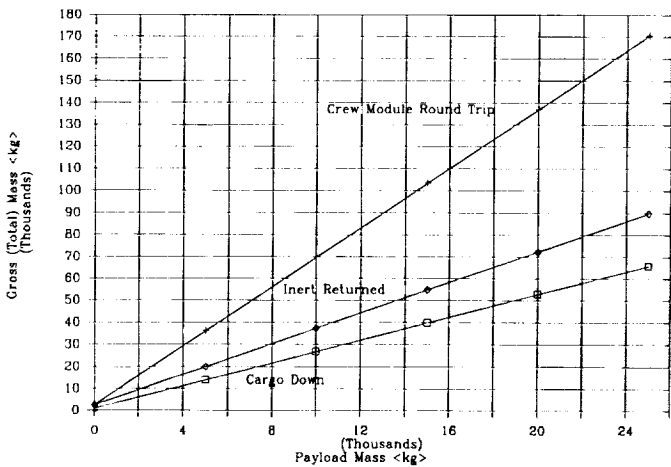

Fig. 3. Single-stage crew/cargo lander. Orbit = 93 km; MR = 1.9 N/M; Isp = 330.

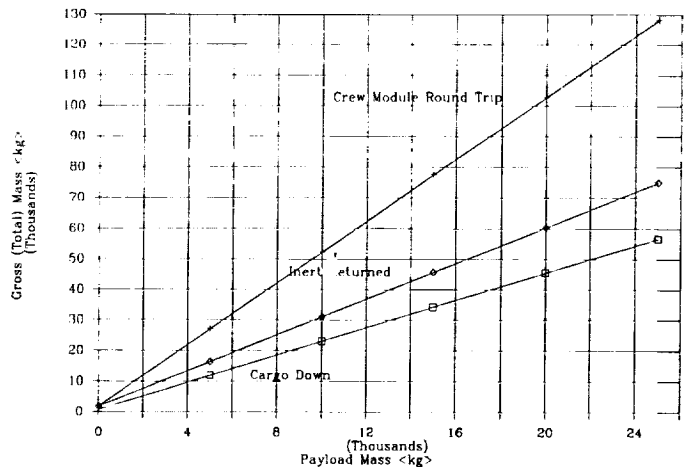

Fig. 4. Single-stage crew/cargo lander. Orbit = 93 km; MR = 6.0 O/H; Isp = 450.

TABLE 1. Lander mass vs. altitude, 6000-kg crew module round trip.

Circ. Orbit Altitude (km)	Isp = 450 sec			Isp = 330 sec		
	Deorbit Mass	Inert Mass	Propellant Mass	Deorbit Mass	Inert Mass	Propellant Mass
93	32	6	20	43	5	32
200	34	6	22	46	5	35
400	37	7	24	50	6	38
1000	46	9	31	66	7	53
L2 (M-LP-E)	166	13	147	344	38	300

TABLE 2. Lander mass vs. altitude, 25,000-kg cargo down case.

Circ. Orbit Altitude (km)	Isp = 450 sec			Isp = 330 sec		
	Deorbit Mass	Inert Mass	Propellant Mass	Deorbit Mass	Inert Mass	Propellant Mass
93	57	8	24	66	6	35
200	58	8	25	68	7	36
400	60	8	27	70	7	38
1000	64	9	30	76	7	44
L2 (M-LP-E)	84	13	46	100	11	64

TABLE 3. LEO stack mass as a function of lunar orbit altitude.

LLO Altitude (km)	Lander Deorbit Mass	LEO Stack Mass			
		One-stage OTV		Two-stage OTV	
		LLO	Load lander propellants in LEO	LLO	LEO
<i>6000-kg crew capsule round trip, LLO-LS-LLO, 450-sec Isp Lander</i>					
93	32	111	136	101	127
200	34	120	142	107	133
400	37	121	150	112	140
1,000	46	142	174	131	165
36,000 (L2)	170	500	535	471	506
<i>25,000-kg cargo one way, 450-sec Isp expended lander</i>					
93	57	190	190	174	174
200	58	192	192	176	176
400	60	195	195	180	180
1,000	64	202	202	187	187
36,000 (L2)	84	268	268	246	246
<i>6000-kg crew capsule round trip, LLO-LS-LLO, 330-sec Isp lander</i>					
93	44	148	169	137	159
200	46	155	172	144	162
400	50	162	184	152	173
1,000	66	205	226	191	214
36,000 (L2)	344	963	1,115	904	1,039
<i>25,000-kg cargo one way, 330-sec Isp expended lander</i>					
93	66	217	217	199	199
200	68	221	221	204	204
400	70	229	229	208	208
1,000	75	238	238	219	219
36,000 (L2)	100	314	314	290	290

All masses are metric tons.  
 All OTVs are LOX/LH<sub>2</sub>, 455-sec Isp.  
 Space station orbit altitude - 450 km.  
 Delta Vs as given in Table 4.  
 All LEO-LLO trajectories are 75-hr transfers.  
 No plane changes are accounted for.  
 OTVs are "rubber" and optimized to the given payload.  
 OTVs assume: 15% of entry mass is aerobrake, 5% of propellant is tankage, etc., 2.3% of propellant is FPR and unusables.  
 Other OTV inerts = 2.5 m tons for two-stage, 4.5 m tons, for one-stage.

however, as the orbit altitude increases above 1000 km, plane change  $\Delta V$  goes down drastically, but the lander mass goes up drastically due to increased ascent and descent  $\Delta V$  (Table 4).

The ability to change planes widens the launch window the vehicle has to reach high-inclination lunar orbit. For a landing site such as Lacus Verus at 13°S latitude, it might allow a lander to ascend to an OTV or LLO space station in lunar equatorial orbit at any time. This is a highly desired feature. For a high-latitude base and parking orbit, polar for instance, a 15° plane change capability would allow launch on roughly 4.5 days out of 27 days in a lunar month.

TABLE 4. Delta Vs.

Lunar Orbit	TLI	LOI/TEI*	Total
93	3.101	0.846	3.947
200	3.101	0.832	3.933
400	3.102	0.809	3.910
1,000	3.102	0.759	3.861
35,000 (L2, M-IP-E)	3.084	0.863	3.947

\* LOI and TEI are assumed to be the same.

### PROPELLANT LOADING LOCATIONS

There are several options for lander propellant loading locations. In addition to propellant loading, the lander must be serviced with other consumables, maintained, and periodically tested. Two straightforward options include (1) returning the lander to the space station after each mission to the surface and servicing and loading it with propellants at the space station or (2) loading the lander with propellants in lunar orbit and servicing and maintaining it in lunar orbit.

The concept of maintenance and propellant transfer in space is new. The space station will already have propellant loading, maintenance, and refurbishment facilities for the OTVs. The space station will have the largest stock of spares, most personnel, shortest logistics tail, etc. Maintenance man-hours in space will cost least at the space station. Development cost will be reduced in that facilities required for the OTVs can be designed to service the landers as well.

Bringing the lander back requires a larger stack in LEO. Table 3 illustrates this. Given the OTV transportation system described, bringing the lander back can cost as much as 25% more LEO mass in one mission than loading propellants in lunar orbit. Loading propellants in lunar orbit will also have costs however. The lander will be left in a given orbit that the next mission must fly too. Some performance loss or loss in mission flexibility will be associated with this. If a facility is required in lunar orbit to handle propellant transfer, then the flights needed to place and support this facility represent a performance loss on the system.

It is difficult to integrate the lander with an aerobrake. An OTV specially configured to carry the lander will be required, or the lander will require its own aerobrake and will be an independent vehicle on return to Earth.

If it is practical to design a lander that can be loaded with propellants and other consumables and be maintained and checked out in lunar orbit without a fixed facility (a small lunar orbit space station), then this is a more attractive option. There is debate about the practicality of basing a reusable vehicle at the space station however. The further away from Earth a vehicle is based, the more expensive and difficult maintenance, repair, and

testing will become. Other performance losses would be associated with operation from a fixed orbit. These losses will go up as inclination of the lunar orbit goes up. If the base is equatorial, this will not be a problem.

### MAIN ENGINES

Table 5 shows various thrusts and throttling ratios estimated to be required in different circumstances. The deorbit cases assume an acceleration of 9 ft/sec<sup>2</sup> or 2.74 m/sec<sup>2</sup> is required at the start of the burn. The ascent case assumes an acceleration of 6 ft/sec<sup>2</sup> or 1.83 m/sec<sup>2</sup> is required. The hover case assumes 40% of the lunar weight is the minimum hover thrust. All these assumptions match Apollo numbers. New trajectories need to be run with these vehicles to see how these numbers can be varied.

The widest range is between deorbiting a 25,000-kg payload from a higher low orbit with a low-performance propellant (43,000 lbf required) and hovering a crew capsule and the vehicle inert mass just before running out of propellant as might occur in an abort to the surface or a normal landing requiring propellant loading on the surface (1760 lbf). The ratio between these two cases is roughly 24:1. The Apollo LM engine was designed with a 10:1 throttling ratio. If the minimum thrust case is taken as a normal landing for an H<sub>2</sub>/O<sub>2</sub> lander with a crew capsule (2957 lbf), the throttling ratio becomes 13:1. Table 5 shows a variety of cases and how the throttling ratio might vary.

TABLE 5. Comparison of throttling ratios.

Max. Thrust (lbf) Orbit Alt., Isp, Prop. Situation	Min. Thrust (lbf) Situation	Throttling Ratio
37,000 400 km/450 sec/O <sub>2</sub> /H <sub>2</sub> Deorbit with 25,000-kg cargo	1760 40% of hover, near empty with crew capsule only, abort to surface.	21:1
35,665 93 km/450 sec/O <sub>2</sub> /H <sub>2</sub> Deorbit with 25,000-kg cargo	1760 40% of hover, near empty with crew capsule only, abort to surface.	20:1
37,000 400 km/450 sec/O <sub>2</sub> /H <sub>2</sub> Deorbit with 25,000-kg cargo	2957 93 km, 450-sec Isp 40% of hover before normal landing, 6000-kg capsule	13:1
19,731 93 km/450 sec Deorbit with 6000-kg crew capsule	2957 93 km, 450-sec Isp 40% of hover before normal landing, 6000-kg capsule	7:1
19,731 93 km/450 sec Deorbit with 6000-kg crew capsule	1760 40% of hover, near empty with crew capsule only, abort to the surface	11:1
35,665 93 km/450 sec/O <sub>2</sub> /H <sub>2</sub> Deorbit with 25,000-kg cargo	4693 93 km, 450-sec Isp, O <sub>2</sub> /H <sub>2</sub> 40% of hover, near empty with 25,000-kg cargo	8:1
43,000 400 km/330 sec Deorbit with 25,000-kg cargo	1760 40% of hover, near empty with crew capsule only, abort to the surface	24:1

Reducing the required throttling ratio may have significant advantages. The single, pressure-fed Apollo LM engine was cooled by ablation of the nozzle. A reusable engine must be regeneratively cooled. Pressure-fed regenerative cooling over a wide throttling ratio may not be possible due to the flow changing a great deal. This leads to a pump-fed engine, a much more complicated device, which then leads to two or more engines for redundancy. A single-purpose lander, to land only a crew, might function with a pressure-fed single engine. Table 5 indicates a throttling ratio of 7 or 8 to 1 might be enough if one lander were not required to bring down the 25,000-kg cargo and the crew capsule as well. The table indicates that a dedicated cargo lander and a dedicated crew lander would each require a throttling ratio of 7 or 8 to 1. The crew lander might use one or two engines and the cargo lander four. Other schemes involving shutting off or not using engines are also possible, but result in inert mass penalties. Another option would be to reduce the lander deorbit acceleration. The penalties for doing this should be determined.

On the other hand, pump-fed, cryogenic engines may be able to function well in the 20:1 throttling ratio regime as some individuals have claimed. Less work has been done on storable engines with wide throttling ratios. The pump-fed engine may be required even at low throttling ratios because of cooling problems. The relationship between throttling ratio and engine cooling needs to be determined. In particular, the highest throttling ratio, pressure-fed, regeneratively cooled engine, that will work, must be determined. If it is below 7 or 8, pressure-fed engines can be eliminated as candidates.

Another possibility is a partially ablative engine. The combustion chamber and throat could be regeneratively cooled and the majority of the nozzle could be ablative, designed for easy replacement every few missions, which might allow a pressure-fed system to be used.

The Adaptable Space Propulsion System (ASPS) studies and the OTV studies have narrowed the propellants to  $N_2O_4/MMH$  and  $O_2/H_2$ , respectively, using pump-fed engine cycles. Some of the technology efforts for the ASPS and OTV engines are underway and more are planned. The lunar lander propulsion system can benefit from this technology to a great extent. However, a propulsion system designed especially for the lunar lander should also be studied and compared to determine the technical penalties of using the ASPS/OTV technology engines vs. the cost and time penalties of developing another engine. Additional technology requirements resulting from the lunar lander studies could be added to the ASPS/OTV engine technology programs. This would decrease cost and development time for the lunar lander engine program.

## PROPELLANTS

There are many propellant combinations to consider for the lunar lander study. For initial vehicle sizing the Earth-storable combination  $N_2O_4/MMH$  and the cryogenic combination  $O_2/H_2$  are selected (see Table 6). These propellant combinations are being studied for other space propulsion systems and experience has been gained by their use on operational spacecraft and booster vehicles. All the previous tables and figures can be used to compare the performance of these two propellants. In general, the  $O_2/H_2$  lander and LEO stack is 10-30% lighter. The OTVs are all assumed to be  $O_2/H_2$ . More study of the inert mass is needed to better qualify this difference, however. A point design of an  $O_2/H_2$  lander is needed to get good inert weights.

TABLE 6. Engine characteristics to be used for initial vehicle sizing.

	$O_2/H_2$	$N_2O_4/MMH$
Thrust (lbf)	12,334	
Chamber Pressure (psia)	1,270	
Mixture Ratio (O/F)	6.0	1.9
Max Isp (sec)	460	340
Ave. 14:1 Isp (sec)	450	330
Nozzle Area Ratio	620	
Nozzle Exit Diameter (in)	60	
Engine Length (in)	115	
Weight (lb)	525	

There are other propellant combinations to be investigated such as  $O_2/C_3H_8$  and  $O_2/C_2H_4$ , which have higher performance than  $N_2O_4/MMH$ ; however, the propellant bulk densities are lower. The combinations should be reviewed when the thrust chamber cooling requirements and performance are investigated for high throttling ratios. These propellants could take advantage of surface-produced oxygen at some point in the future without the problems of long-term hydrogen storage.

Pressure-fed propulsion systems with the Earth-storable propellant combination  $N_2O_4/Aer50$  were used for the Apollo spacecraft propulsion systems for simplicity and reliability. The Apollo descent-stage thrust chamber (nonreusable) was ablatively cooled while the lunar lander thrust chamber (reusable) requires regenerative cooling. The estimated throttling for the lunar lander cannot be achieved with a pressure-fed system using a regeneratively cooled chamber and reasonable tank and system weights. Therefore, the lunar lander will be pump-fed unless some innovative method for thrust chamber cooling is discovered that would then allow a pressure-fed vs. pump-fed comparison.

Achieving the required throttling and cooling with an Earth-storable propellant, pump-fed propulsion system will also be difficult and could prove unfeasible. The system would become too complex if two engine designs (different maximum thrust levels) and shutdown of engines became necessary to attain the overall thrust variation.

## NUMBER OF ENGINES

The complexity of a pump-fed engine requires at least two engines for a manned space vehicle so that one engine failure will not result in loss of crew. Vehicle control system requirements and effective Isp must be considered in selecting the number of engines, i.e., thrust vector control and loss of Isp due to nonparallel engines if an engine fails.

Four engines have been tentatively selected for the initial study. The engine size is smaller than a two- or three-engine configuration and the throttling ratio is lower. The maximum thrust required for the  $O_2/H_2$  lunar lander configuration is assumed to be 37,000 lb (see Table 5). For manned missions, if one engine fails during lunar descent the mission will be aborted to lunar orbit since redundancy would be lost for lunar launch. Thrust would be adequate with two of the four engines operating, but thrust vector control would be a problem. For unmanned missions, if one engine fails during lunar descent, the mission will be continued to lunar landing since there is no problem with loss of crew, and at some point in the descent insufficient propellant will be available to abort to lunar orbit. With these ground rules, the selected maximum thrust level for each of the four engines is 12,334 lb. This results in a total maximum thrust of 37,000 lb in the event one engine fails during the unmanned lunar descent,

and the lunar lander still has the capability to land, where a normal landing determines minimum thrust on the lunar surface as planned. The throttling ratio required per engine is 13.4:1. An ascent/descent simulation with aborts is needed to refine these numbers.

Another approach to obtain pump-fed engine redundancy is the use of a single thrust chamber with two sets of turbopumps and associated controls. This would result in a single thrust chamber of 37,000-lb thrust with a slight gain in performance (higher area ratio) and a simplification of the thrust vector control. Relying on a single, reusable, regeneratively cooled thrust chamber with the associated deterioration as missions are added would be one reason to reject this approach. An extremely critical inspection of this chamber would be required between missions if this engine system were selected.

The performance figures for  $N_2O_4/MMH$  are satisfactory for preliminary vehicle sizing. Further information on engine cooling is required before additional engine characteristics can be determined. The use of a single, 37,000-lb-thrust, pump-fed engine should be investigated since a large engine results in lower thrust chamber cooling requirements. This investigation should include the use of both propellants for thrust chamber cooling, the integration of redundant turbopump operation, and the possible requirement of a variable-area injector as used on the Apollo descent engine to improve performance throughout the throttling range.

The present technology goal for the OTV engine is an operational life of 500 starts/20-hr burn time, and a service-free life to 100 starts/4-hr burn time. Based on the Apollo LM burn times this would allow approximately 58 operational missions and 11 service-free missions. This is a goal. The space shuttle main engine (SSME) requires reservicing every mission and is effectively replaced, on average, every three missions.

## REACTION CONTROL SYSTEM (RCS)

The RCS propellants for the  $O_2/H_2$  lunar lander are proposed to be also  $O_2/H_2$  and are loaded into the main propellant tanks. Liquid propellants are extracted from the main tanks, pumped to a higher pressure, gasified by passing through a heat exchanger, and then stored in accumulator tanks as gases to be used in gas/gas RCS thrust chambers. The gas generators to operate the turbopumps use gaseous oxygen/gaseous hydrogen and the exhaust gases are passed through the heat exchanger to gasify the LOX and  $LH_2$  as mentioned previously. Sixteen thrusters are located in four clusters  $90^\circ$  apart, four engines per cluster, to supply the required control and translation thrust. The thrust of each RCS engine is approximately 100 to 150 lb depending upon vehicle requirements. The Isp is 370 sec, steady state.

The RCS propellants for the Earth-storable lunar lander are the same as for the main engine,  $N_2O_4/MMH$  with separate RCS propellant storage tanks and pressurization system. The engines are pressure fed and the Isp is about 280 sec, steady state.

Integrating the  $N_2O_4/MMH$  main propulsion system and the RCS resulting in smaller RCS tanks and the elimination of the RCS pressurization system is a possibility and warrants investigation.

## SUPPORTABILITY

Support of the lander for an extended period of time will require a different approach to all the supportability disciplines than those that have been used for NASA manned spaceflight

programs through the space shuttle era. A new approach to reusability, maintenance, and repairability considerations is needed.

Technology available in the early 1990s can, in most cases, produce sufficiently reliable hardware and software to support the lunar lander scenario if proper management emphasis is given to it. The space environment is, in many ways, quite benign and conducive to long life and high reliability.

Past NASA manned space programs, most notably Apollo and space shuttle, have been initiated with the intent of providing in-flight maintenance capability; however, these requirements were either deleted from the program or not pursued with sufficient rigor and dedication to provide meaningful results. It will be necessary for the supportability requirements to be given continuous high priority throughout the life cycle of the lander if it is to achieve the current goals of space basing and long useful life.

If true reusability with acceptable reliability is to be achieved, these considerations must be given high priority from program initiation onward. The current manned spacecraft redundancy requirements will, in general, provide sufficient reliability for the lander. To achieve high reliability it will be desirable to use proven technology in as many of the vehicle systems as possible and still meet the performance requirements. If the lunar lander is adequately maintained and repaired then the reusability goal can be met. The major exception may well occur in the main propulsion system inasmuch as high-performance rocket engines with life expectancies of the order needed to satisfy the lander design requirements are not available.

Designing to achieve efficient space-based maintenance will give rise to new problems and require unique approaches to keep maintenance activity to an acceptable portion of the overall manpower available. Teleoperated robotic technology is one possibility. Another approach, shown in the conceptual design, is a large pressurized volume on the lander that can be docked to the space station and can be designed to hold most equipment requiring maintenance, servicing, or replacement.

## DATA MANAGEMENT AND GUIDANCE, NAVIGATION, AND CONTROL (GN&C)

The multipurpose lander must land with cargo unmanned as well as manned. Sophisticated automatic fault detection, identification, and reconfiguration (FDIR) will be required.

The vehicle must be designed from the onset to be entirely self-checking and rely on onboard calibration. Most of the maintainability functions specified for the space station are also applicable to the lunar lander.

In addition, the lunar lander design must be capable of autonomous launch. The Apollo program demonstrated many aspects of the capabilities needed to launch and operate a vehicle without the benefit of a costly launch check-out facility. With the advances in expert system design and the increases in onboard computer power the autonomous checkout goals should be readily achievable but require that these functions are recognized as primary requirements.

The data management system (DMS) is defined as the redundant central processing system, multipurpose displays, data bus network, and general purpose multiplexor-demultiplexors. The software system is also included. Although the DPS processors accomplish the principal function processing, processors are

implemented at the subsystem or black box level to perform data compression, FDIR functions, and other functions amenable to local processing. These local processors would be procured to be card compatible with the main processor. All items required to interface with the standard data bus are procured with a built-in data bus interface.

The DMS processor recommended is a 32-bit machine derived from a commercial chip to capitalize on the advantages of off-the-shelf software, support tools, and the many other advantages that accrue from having a readily available ground version of the onboard machine. For the purpose of this conceptual design a version of the Intel 80386 microprocessor was assumed.

Two multipurpose displays are proposed using flat screen plasma technology. The operations management software supports the monitoring of onboard consumables, system configurations, and failure status, and displays this information for the benefit of space station checkout crews or, when applicable, to the lunar lander crew members. The display system also supports the flight displays for mission phases when manual control is available.

The IMU proposed is a strapped down system based on ring-laser gyro technology. This approach is chosen because of advantages in cost, ruggedness, stability, and ease of integration with optical alignment devices. Projected advances over the next few years also show a clear advantage in weight and power over other types of inertial systems. The ring-laser gyro is readily adaptable to a "Hexad" configuration that provides the maximum redundancy for the least weight and power. The "Hexad" configuration contains a built-in triple redundant inertial sensor assembly (ISA) processor that does the strapdown computations, sensor calibration, redundancy management, checkout, and other local processing assignments. The ISA processor also calculates the vehicle attitude and vehicle body rates required for control system stabilization.

Alignment of the IMU will be required prior to descent and ascent to minimize errors and  $\Delta V$  expenditure. This is accomplished by an automatic star scanner attached to the case of the IMU to minimize boresight errors.

Guidance functions, control equations, jet select logic, and similar processes are mechanized in the DMS processor. To the maximum extent possible, these and other critical functions will be implemented in read-only memory (ROM) to provide the maximum reliability and lowest power and weight penalties. Commands to the main engines and RCS engines are transmitted via the triple-redundant data bus to the control electronics sections where electrical voting takes place before transmittal of the command to the actual effectors.

Automatic docking of the lunar lander with the OTV is a requirement; however, the OTV is assumed to be equipped with the sensors and intelligence to accomplish this operation, and no provision is made on the lunar lander to duplicate this capability. Wherever the capability resides, it must be developed. The sensors and software to do automatic docking do not exist at this time in the free world.

A variety of systems are possible for updating the onboard inertial system and performing landing navigation. The preferred system is the cruise missile-type terrain-following radar with surface-based transponders. The basic elements of this system will all be part of the landers anyway, and depending on the surface features and the knowledge of their positions, no surface elements at all may be required. A small surface-based radar would be a low-cost addition to the onboard terrain-following system.

The first requirement for terrain-following-type navigation is knowledge of a terrain feature's location to within a certain range of error. If the first landings on the site are manned, they must occur during lighting conditions allowing good visual landing navigation. The first landers can carry a transponder and, if required, place another on the surface at a known location. Subsequent landings will then get positions relative to these transponder(s). Table 7 estimates the mass, power, and volume required for each component.

## ENVIRONMENTAL CONTROL AND LIFE SUPPORT SYSTEMS (ECLSS)

Comparison of open and closed systems were made to determine the crossover point where it pays to go from open loop to a partially closed loop. The crossover point is dependent on several factors: mass, volume, energy, and operational considerations. From the mass standpoint, the crossover point was approximately 60 days for the atmosphere revitalization system, and 35 days for the water management system. Neither of these two comparisons took into account the impact on other subsystems such as power and thermal control. With the identified power requirements, these impacts should be added to the ECLSS mass impacts to arrive at a reasonable mass break-even point. As a point of reference, a partially closed loop system is estimated to require on the order of 4 kW of power and have hardware masses of around 3000 kg. Open-loop systems are predicted to require 1 kW of power and have a hardware mass of 1300 kg for 15-day missions. The break-even point will be at an even longer stay time when the additional power system mass required is considered. Three- to 15-day missions are under consideration for the lander. For these reasons, the system design selected was the open-loop configuration (see Table 8).

The choice of power generation method can also bias the choice of ECLSS design selection. If fuel cells are used to generate electricity, then the process byproduct, water, can be used in the open-loop concept.

The atmosphere supply and pressurization system source consists of tanks of gaseous high-pressure nitrogen and oxygen. If fuel cells are used for electrical power, then the system would get oxygen from a common cryogenic supply tank. These sources are fed through regulators to support the cabin, crew suits, airlock, and EMU station. Provisions are available for cabin and airlock depressurization and repressurization. Equalization valves are available at each pressure volume interface. Partial pressure sensors will be connected to the regulators to maintain the proper atmosphere composition mix.

Atmosphere revitalization is supported by LiOH canisters for CO<sub>2</sub> removal. Odors and particulates will be removed by activated charcoal and filters. Cabin fans provide the necessary circulation of the atmosphere through the system and habitable volume. Humidity and temperature control will be handled by heat exchangers and water separators. Thermal control for other equipment in the crew compartment will be handled by cold plates and a water loop connected to the thermal control system. Included in this subsystem will be the fire detection and suppression system.

Shuttle power requirements, itemized by systems that might be comparable to lunar lander systems, were added up. The average power required based on this calculation was 1.81 kW. The shuttle is designed for a nominal crew of 7 with a contingency of 10.

TABLE 7. DMS/GN&amp;C mass and power.

Component	Unit (Vehicle) Weight (kg)	Unit (Vehicle) Power (W)	Unit cubic ft Volume (Config.)	Number/Vehicle
DMS Processor	10 (30)	75 (225)	0.27 (0.81)	3
MDM	7.7 (46.4)	60 (360)	0.25 (1.5)	6
ANK/Display*	8.6 (17.3)	40 (80)	0.35 (0.7)	2
Hexad IMU	16 (16)	75 (75)	0.3 (0.3)	1
Star Track	2 (6.1)	10 (30)	0.1 (0.3)	3
Nav. Sensors				
Landing	13.2 (13.2)	100 (100)	0.4 (0.4)	1
Rendezvous	20.5 (20.5)	200 (200)	0.6 (0.6)	1

\* ANK = alpha-numeric keyboard.

Total Weight = 149.3 kg (325.5 lb).

Total Power = 1070 W.

Total Volume = 0.13 cu m (4.61 cu ft).

TABLE 8. Open-loop ECLSS mass required.

No. of Crew	Support Time (days)	Consumables (3 airlock cycl. kg)	Hardware (kg)	Fluids (kg)	Crew Prov. (+crew mass) (kg)	Total (kg)
6	1	72	1264	214	2562	4112
4	3	133	1264	214	1708	3319
6	15	894	1264	214	2562	4934
4	15	612	1264	214	1708	3798

The lander crew module holds four with a contingency of six. The power requirement is assumed to be roughly linear with crew downsized by 4/7, resulting in a requirement for 1.0 kW average power. Increased efficiency in motor design and advanced cooling techniques occurring over the 20-30-year interval between the two vehicles is expected to result in some savings as well.

## ELECTRICAL POWER

Two scenarios have been discussed with respect to the crew module. In one scenario the crew only enters the module to descend to the surface and lives in another module in-orbit. In the second scenario, the crew lives in the lander module for the complete trip, estimated to be 15 days minimum. For this reason the lunar lander mission is broken down into two scenarios for the electrical energy storage provisions: (1) Power up in lunar orbit; descent, three days on surface; ascent to lunar orbit — 144 kWhr at 2 kW average. (2) Power up in LEO one day; three days to lunar orbit; one day in lunar orbit; descent, three days on surface; ascent, one day in lunar orbit; three days to LEO; three days in LEO — 720 kWhr at 2 kW average (15 days).

The lander may stay much longer than three days on the surface, but it is assumed that external power will be provided. In either case it is assumed that the power system would be serviced at the space station in LEO.

The 2-kW average power requirement is an estimate based on the Apollo LM (peak power 2.3 kW) and calculations indicating DMS/GN&C and ECLSS will each require about a kilowatt. This may be reduced, but there will be other power requirements. A more conservative estimate might be an average power requirement of 3 kW.

Fuel cells and a number of ambient temperature batteries were compared. The shuttle-derived fuel cell yields the system of lowest weight and greatest flexibility. For large energy (>50 kWhr) requirements the fuel cell becomes the candidate of choice primarily due to the large energy content of the reactants, H<sub>2</sub> and O<sub>2</sub>, supplying approximately 2200 Whr/kg (tankage not included). The reactant can be stored as a high-pressure gas, a liquid in dedicated tanks, or the main propellant tanks can be used.

There is no impact from adding the fuel cell reactants to the propellant tanks; 31 kg H<sub>2</sub> adds 26 mm to the diameter of each H<sub>2</sub> tank, an increase of 0.7% for each parameter, and 244 kg O<sub>2</sub> adds 6 mm to the diameter of each O<sub>2</sub> tank, an increase of 0.9% and 0.3% respectively for each parameter. This provides energy storage of 200% of that required for the 15-day mission. Getting the reactants out of the large tanks when only small quantities are left may be a problem, however.

The fuel cell operating temperature range is between 80° and 95°C. It is provided with a fluid loop heat exchanger that is integrated with the ECLSS thermal control loop, just as in the shuttle orbiter. Heat rejection will be approximately 4400 btu/hr at the 2-kW power level.

Fuel cell product water is portable and useful for crew consumption and evaporative cooling. It is produced at the rate of about 3/4 l/hr at the 2-kW power level for a total of 260 kg for the 15-day mission. It is delivered to the fuel cell interface in liquid form for transfer to the ECLSS system. Therefore, storage and plumbing are not included in the power system design. However, for single tank storage, a tank of 0.8 m in diameter is required.

The baseline system used in the weight statements is a dual redundant fuel cell system using dedicated tanks for cryogen storage. Table 9 estimates the total mass of the system that

TABLE 9. Fuel cell options.

H <sub>2</sub> /O <sub>2</sub> Fuel Cells (100% redundancy, 15-day mission, 720 kWhr)		
	Energy Density (Whr/kg)	System Weight (kg)
Dedicated Cryo Tanks	391	1842
Integrated with Propellant Tanks*	1051	685

\* Added weight of propellant tanks for slight increase in diameter not included. Reactants are included.

Fuel Cell System Analysis (no redundancy)*						
Reactants (kg)	Tank Diameter (m)	Tank Weight (kg)	F.C. weight (kg)	System weight Fc,Rx,Tank	Energy Density (Whr/kg)	
<i>Gaseous</i>						
720 kWhr (15 days)						
H <sub>2</sub> 30.9	1.57	442	68	1000	720	
O <sub>2</sub> 243.7	1.46	215				
144 kWhr (3 days)						
H <sub>2</sub> 6.2	0.92	88	68	254	567	
O <sub>2</sub> 48.8	0.73	43				
<i>Cryo</i>						
720 kWhr (15 days)						
H <sub>2</sub> 30.9	0.94	224	68	921	782	
O <sub>2</sub> 243.7	0.74	354				
144 kWhr (3 days)						
H <sub>2</sub> 6.2	0.55	45	68	239	603	
O <sub>2</sub> 48.8	0.43	71				

\* 1 fuel cell, 1 set of tanks.

Included in weights: 10% fuel cell weight for mounting; 10% tank weight for plumbing/mounting; 5% reactant weight for ullage.

provides 2 kW for 3 days as 478 kg. An equivalent system that uses the main propellant tanks for reactants might weigh 274 kg (dual redundant, not counting tank mass increase).

## MULTIPURPOSE LANDER WEIGHT STATEMENTS

Table 10 shows a multipurpose lander weight statement. The cargo landing task results in the largest deorbit mass that scales the structures, engines, RCS dry mass, and landing systems. The round trip with a crew module results in the largest propellant mass that scales the tanks and thermal protection. The electrical power system uses four dedicated tanks for redundant reactant storage. The  $\Delta V$  includes an additional 0.43 km/sec for a 15° plane change.

The multipurpose lander pays a penalty of 2300 kg (lunar deorbit mass) in the crew module case for being able to do all three tasks, as compared to a lander designed to do only a round trip with a crew module. The scaling equation described previously was used to determine these masses.

The plots shown in Figs. 2, 3, and 4 and tabulated in Tables 1, 2, and 3 are for similar landers, except the 0.43 km/sec  $\Delta V$  for plane change is not included and no mass for the airlock/tunnel is included. They are therefore smaller landers. Table 11 shows the same lander sized for N<sub>2</sub>O<sub>4</sub>/MMH propellants.

## LH<sub>2</sub>/LOX MULTIPURPOSE LANDER CONCEPTUAL DESIGN

Figures 5 and 6 show a conceptual design of an LH<sub>2</sub>/LOX multipurpose lander. The tanks are sized to hold roughly 30,000 kg total of propellant. The H<sub>2</sub> tanks are 3.9 m in diameter, and the O<sub>2</sub> tanks are 2.76 m in diameter. The weight statement for this lander is given in Table 10.

Important features of this lander include (1) airlock/servicing tunnel down the center of the lander to allow easy access on the surface, and pressurized volume for LRUs, inside which many engine connections can be made and broken; (2) flyable without the crew module, which is removable; (3) fits in 30' heavy-lift vehicle shroud with landing gear stowed; (4) electromechanical shock absorbers on landing gear; and (5) emergency ascent with one or two crew possible without crew module (crew would ride in suits in airlock/servicing tunnel). Figure 7 shows this lander being serviced on the lunar surface and illustrates how the airlock/servicing tunnel allows pressurized access to a surface vehicle. An engine is being removed in the figure.

Figure 1 shows this lander in lunar orbit, about to dock with a large (single-stage) OTV. The OTV is designed to return the lander to the space station for servicing. The OTV delivers the lander to LLO, single stage, and waits in orbit for it to return. The OTV tanks are sized to hold 118,000 kg of LOX/LH<sub>2</sub> propellants.

TABLE 10. LO<sub>2</sub>/LH<sub>2</sub> multipurpose lander weight statement.

Delta V, Ascent	0	2.28*	2.28*
Payload, Ascent	0	6,000	0, Inert Mass returned to LLO
Delta V, Descent	2.10	2.10	2.10
Payload, Descent	25,000	6,000	14,000
Total Inert Mass	9,823	9,823	9,823
Structure	1,681	1,681	1,681
Engines	822	822	822
RCS Dry	411	411	411
Landing System	784	784	784
Thermal Protection	2,017	2,017	2,017
Tanks	3,025	3,025	3,025
DMS (GN&C)	150	150	150
Electrical Power †	478	478	478
Airlock/Tunnel	455	455	455
Total Propellant Mass	25,251	32,395	30,638
Ascent Propellant	0	11,334	7,240
Descent Propellant	22,597	18,137	20,486
Unusable Propellant (3%)	678	884	832
FPR Propellant (4%)	904	1,179	1,109
Usable RCS	858	689	778
Unusable RCS (5%)	43	34	39
FPR (20%)	172	138	156
Deorbit or Gross Mass (less payload)	35,074	42,218	40,461
Deorbit or Gross	60,074	48,218	54,461

\* Delta V = 1.85 + 0.43 km/sec for a 15° plane change in a 93-km circular orbit.  
 † Electrical power provided for three days only (2 kW). 100% redundant fuel cells have dedicated redundant tankage.

All masses are kg, all ΔVs, km/sec, Isp = 450 (lbf · sec/lbm).

TABLE 11. N<sub>2</sub>O<sub>4</sub>/MMH multipurpose landers.

Delta V, Ascent	0	2.28*	2.28*
Payload, Ascent	0	6,000	0, Inert mass returned to LLO
Delta V, Descent	2.10	2.10	2.10
Payload, Descent	25,000	6,000	14,000
Total Inert Mass	7,899	7,899	7,899
Structure	1,955	1,955	1,955
Engines	956	956	956
RCS Dry	478	478	478
Landing System	912	912	912
Thermal Protection	1,006	1,006	1,006
Tanks	1,509	1,509	1,509
DMS/GN&C	150	150	150
Electrical Power †	478	478	478
Airlock/Tunnel	455	455	455
Total Propellant Mass	36,398	50,767	45,429
Ascent Propellant	0	15,702	9,406
Descent Propellant	32,861	30,665	31,927
Unusable Propellant	986	1,391	1,240
FPR Propellant (4%)	1,314	1,855	1,653
Usable RCS	990	923	961
Unusable RCS	50	46	48
FPR RCS (20%)	198	185	192
Deorbit or Gross Mass (less payload)	44,297	58,666	53,328
Deorbit or Gross	69,297	64,666	67,328

\* Delta V = 1.85 + 0.43 km/sec for a 15° plane change in a 93-km circular orbit.  
 † Electrical power provided for three days only (2 kW). 100% redundant fuel cells/tank sets.

All masses are kg, all ΔVs, km/sec, Isp = 330 (lbf · sec/lbm).

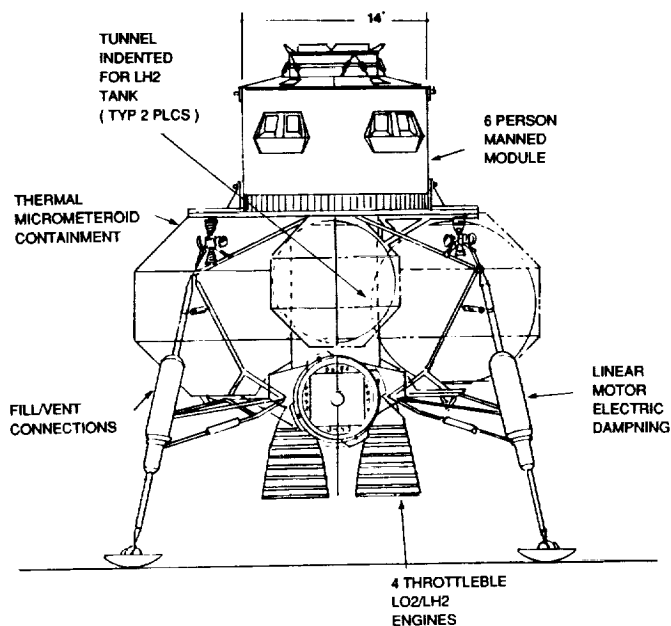
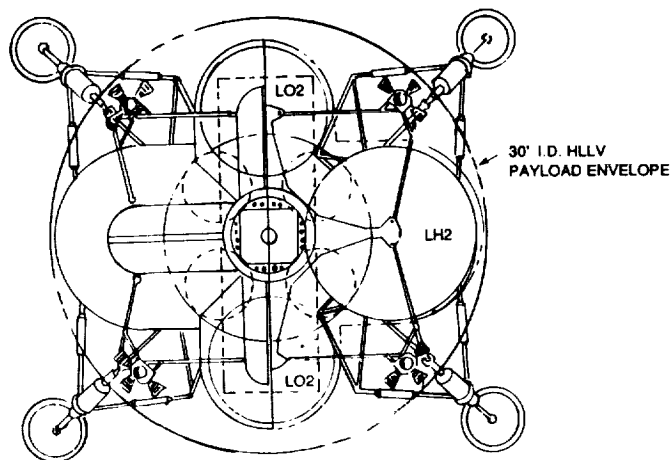

Fig. 5. LOX/LH<sub>2</sub> reusable lunar lander, side view.



SCALE: 1/2" = 1 METER

Fig. 6. LOX/LH<sub>2</sub> reusable lunar lander, top view.

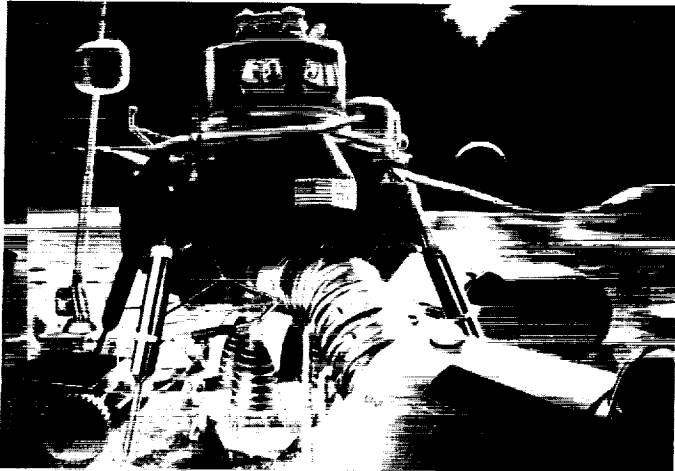

Fig. 7. Lander on surface.

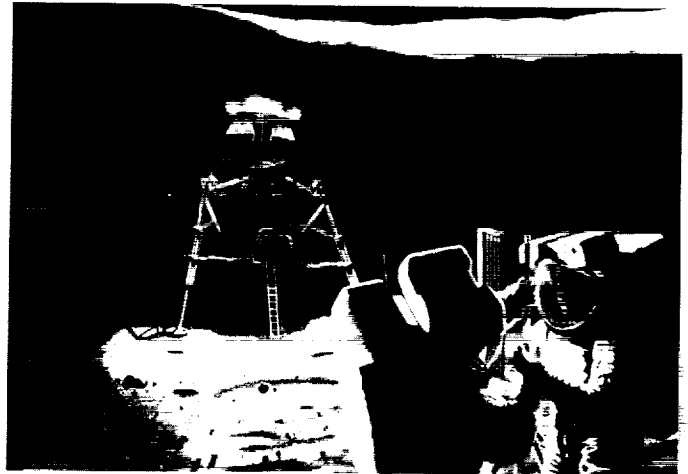

Fig. 8. Lander on surface at pole.

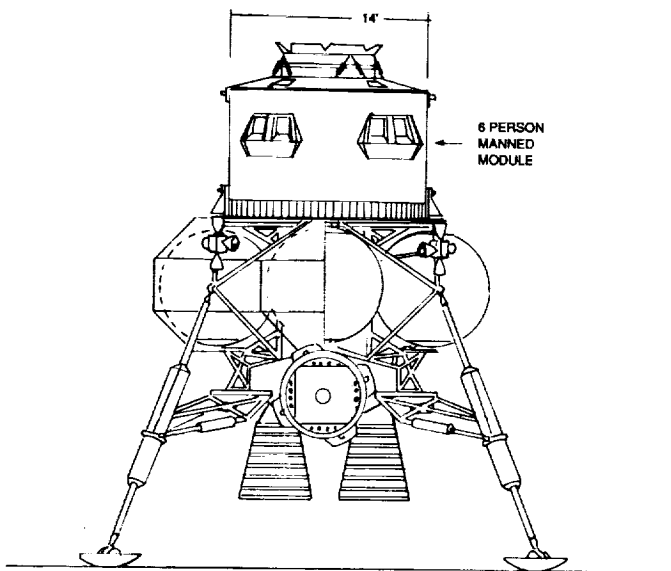

Fig. 9. Advanced reusable lunar lander, side view.

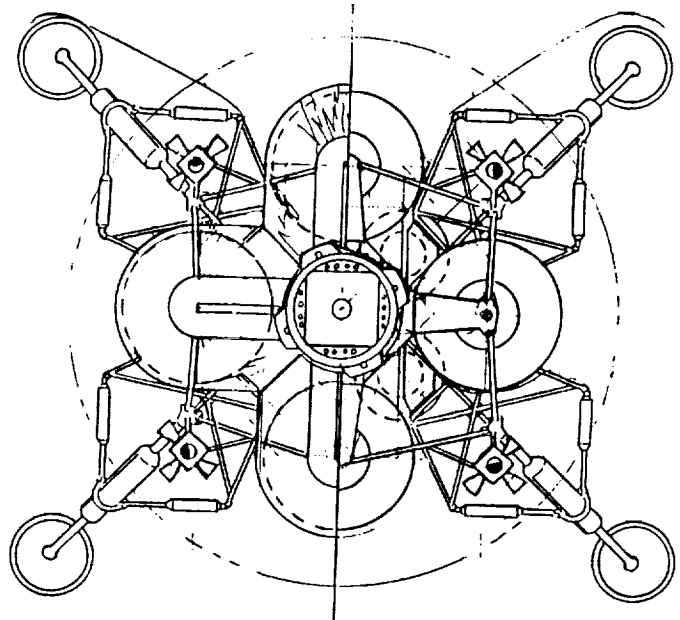

Fig. 10. Advanced reusable lunar lander, top view.

Figure 8 shows the lander on the surface at the poles. The lander may also serve as a suborbital "hopper" if propellant loading on the lunar surface is provided. The figure illustrates normal egress, without a pressurized vehicle.

### ADVANCED STORABLE MULTIPURPOSE LANDER CONCEPTUAL DESIGN

Figures 9 and 10 show a lander with equivalent capability to the LOX/LH<sub>2</sub> lander, except using N<sub>2</sub>O<sub>4</sub>/MMH propellants. This lander, though considerably heavier than the LH<sub>2</sub>/LOX lander, is much smaller, due to higher propellant density. Its features are essentially the same as the previously described lander.

The propellant capacity of this lander is 35,000 kg divided into four tanks of 16 cu m each. Tank diameter is 2.5 m for all tanks.

### COST

Lander production costs were determined using a cost estimating relationship (CER) model. With this method, design and fabrication cost curves are developed for each vehicle component, relating the component's historical costs to its weight. Components from the Gemini, Apollo, Skylab, and shuttle programs were considered when developing the CERs. Where several significantly distinct classes of a given component existed, a separate CER was created for each class. The cost curves generated using this method usually had a correlation coefficient of 0.9 or better. All costs have been adjusted for inflation, and are expressed in 1988 dollars. Program management wrap factors are included in the CERs.

Total design and development cost is estimated to be \$1539 million, and total fabrication cost is estimated to be \$759 million per vehicle. Total program cost for ten vehicles is \$9129 million.

To verify the reasonableness of these estimates, they were compared to actual Apollo LM engineering and fabrication costs. Estimated design and development costs were within 7% of actual LM costs (when adjusted for inflation), and estimated fabrication costs were within 2% of actual LM costs.

<b>Design/Development Costs</b>	
Apollo LM (1967 \$M)*	378
Apollo LM (adj. to 1988 \$M)	1672
New lunar lander (1988 \$M)	1539

<b>Fabrication Costs</b>	
Apollo LM (8 units, 1967 \$M)	1354
Apollo LM (1 unit, 1967 \$M)	169
Apollo LM (1 unit, adj. to 1988 \$M)	745
New lunar lander (1 unit, 1988 \$M)	759

\*These numbers come from a 1967 document (*Grumman Corp.*, 1967). Other significant development costs were incurred after 1967 that are not shown here.

## REFERENCES

- Apollo 11 Mission Report*, MSC-00171. Manned Spacecraft Center, Houston, pp. 7-11.
- Eagle Engineering (1988) *Lunar Lander Conceptual Design*, Report No. 88-181, NASA Contract No. NAS9-17878.
- Grumman Corp. (1967) *Lunar Module Program Cost Summary — Total Program*.