

PRECEDING PAGE BLANK NOT FILMED

PRELIMINARY DEFINITION OF A LUNAR LANDING AND LAUNCH FACILITY (COMPLEX 39L)

N 93 - 17429

H. Dennis Matthews

NASA Kennedy Space Center
Kennedy Space Center FL 32899

Eric B. Jenson and Jerald N. Linsley

Florida Institute of Technology
Melbourne FL 32901

A preliminary definition of a lunar landing and launch facility has been formulated. A permanently manned lunar base and a baseline lunar module are assumed. The major features of the facility are specified and major design areas are described.

INTRODUCTION

We have formulated a preliminary definition of a lunar landing and launch facility (Complex 39L). A Phase III lunar base is considered (Roberts, 1987; Ride, 1987). Without specifying lunar base scenarios, three traffic levels are envisioned: 6, 12, and 24 landings/launches per year. We have assumed a single multipurpose vehicle for the lunar module, whose characteristics will be described below. The design and specifications of the vehicle and of the lunar base are outside the scope of this study; however, these two items will have an impact upon those items considered within the scope of this study because of the interaction at the boundaries of our system. The scope of this study is graphically illustrated by the systems diagram of Fig. 1. Here, major functions or facilities are represented in a block diagram. The dashed line represents the boundary of Complex 39L. This is a simplified version of this diagram. Other items could be included, e.g., lunar surface transportation and electromagnetic launchers. As previously mentioned, those items either on or outside the dashed lines that will have a significant impact upon the design of those

items within the boundary will be discussed. Based upon this diagram, nine major design items are considered: (1) landing/launch site considerations; (2) structure, shelter, safety, and environmental needs; (3) landing/launch guidance, communication, and computing needs; (4) lunar module surface transport system; (5) heavy cargo unloading/loading systems; (6) personnel unloading/loading systems; (7) propellant unloading/loading systems; (8) vehicle storage; and (9) maintenance, repair, test, and check-out requirements.

We provide a general, conceptual description of each of these items. We have obtained preliminary sizes, capacities, and/or other relevant design data for some of these items.

DESIGN SCOPE

The Transportation System and Lunar Module

We assume a baseline transportation system (Astronautics, 1987). The transportation infrastructure (Fig. 2) consists of a low Earth orbit (LEO) space station, a low lunar orbit (LLO) space station, orbit transfer vehicles (OTVs), lunar modules (landers), and a lunar landing and launch facility (Complex 39L). Both the OTVs and the lunar modules will be reusable with no expendable vehicles considered. For the baseline transportation system all vehicle propulsion systems use hydrogen/oxygen (H/O).

The basing scenario includes the space station in LEO to provide servicing, payload accommodation, and propellant supply. Propellant refers to liquid oxygen as well as liquid hydrogen. A similar basing node located at LLO will be needed as a propellant storage depot, and for the servicing of either OTVs or lunar module systems. The final basing node will be at the lunar surface and will have propellant storage, payload transfer, and lunar module servicing capabilities.

For the flight from LEO to LLO the OTV will carry a manned capsule, payload, and propellant for the lunar module and for its return to LEO. For the flight from LLO to Complex 39L the lunar module will carry a manned capsule, payload, and propellant for its return to LLO. Unmanned OTVs and lunar modules in which the manned capsule is replaced with an increased payload can also be used. For this design we assume a preliminary baseline lunar module design.

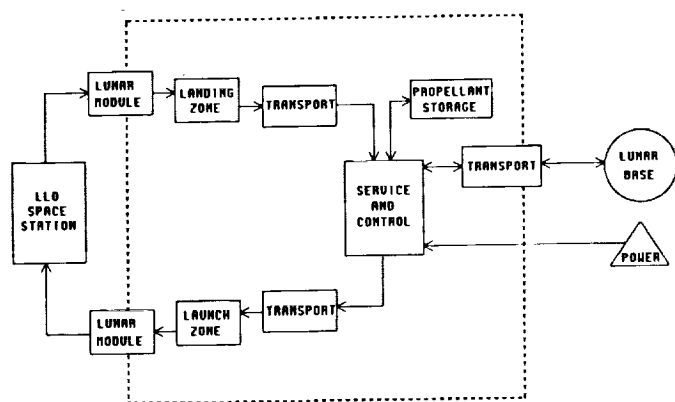

Fig. 1. Lunar landing and launch facility (Complex 39L) systems diagram.

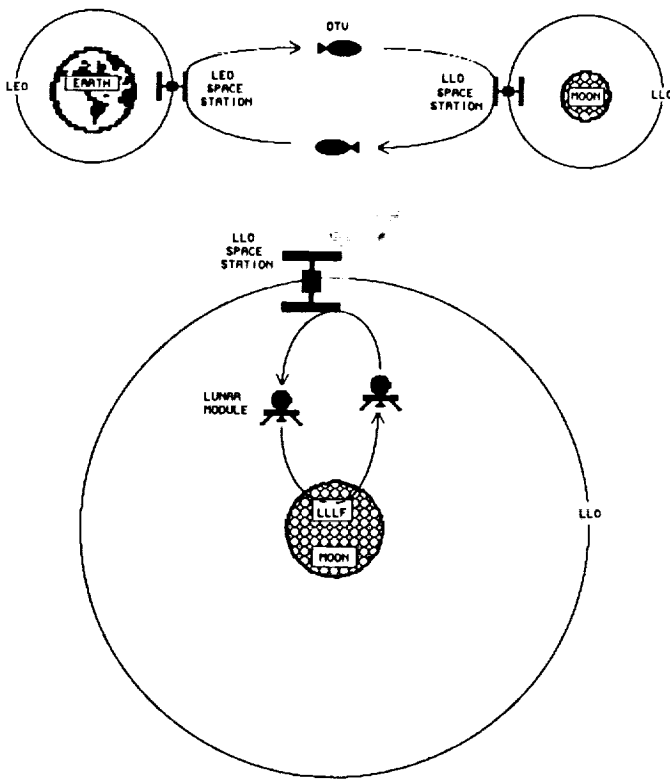

Fig. 2. Earth-Moon transportation infrastructure.

The baseline lunar module is a reusable, two-engined vehicle capable of delivering 15,900 kg (manned capsule plus payload) to the lunar surface from LLO and returning to LLO with an equivalent payload (Astronautics, 1987). Specific engine features are $I_{sp} = 470$ sec, thrust per engine = 33.4 kN, mass per engine = 95 kg, and mass ratio of O_2 to $H_2 = 5.5$. The manned capsule will have the capability of transporting six people (two pilots and four passengers). The lunar module has a propellant capacity of 21,000 and 4000 kg for oxygen and hydrogen respectively. The vehicle lifetime with minimum maintenance is estimated to be 40 flights. Dimensions for the lunar module are estimated from the weight and engine size, and by making comparisons with the lunar excursion module (LEM) used in the Apollo missions. The height (10 m) is the vertical distance from the footpads to the top of the vehicle. The diameter (13 m) is the distance from footpad to diagonal footpad. The lunar module has four footpads. This vehicle is consistent with studies by Johnson Space Center (Alfred, 1987).

It is desirable that the vehicle have a "modular" design, i.e., main subsystems (propellant tanks, engines, cargo modules, manned capsules, etc.) should be easily removable and replaceable. Due to the expense and hazards of extravehicular activity (EVA) it will be advantageous to make maximum use of robotics to perform the required lunar surface tasks (Eagle Engineering, 1987). However, we believe that at this stage in lunar base development many of the tasks will be diverse and complex enough that most repairs will need to be made by personnel wearing spacesuits. This requires special design consideration in an attempt to accommodate the person making the repairs.

The Lunar Base

The lunar base is assumed to be a permanently occupied facility in the timeframe of 2005-2009 (Phase III). The human population will range from approximately 10 to 30 during this time period. The base will emphasize both scientific research and *in situ* resource utilization. It will be desirable to make use of resources available on the Moon in an attempt to minimize the required Earth launch mass (ELM). For this study we take a conservative stance and assume minimal use of lunar resources.

The lunar base can be broken down into several subfacilities. These will include habitat modules, various lunar production facilities, nuclear power facility, and lunar landing and launch facility. A preliminary plot plan for Complex 39L is given in Fig. 3. We now discuss the interaction between Complex 39L and the other subfacilities, i.e., the boundaries of our systems diagram.

It is assumed that habitat and laboratory modules similar to those used in the LEO space station will be used on the Moon. The modules will be covered with lunar regolith for radiation protection (Guerra, 1988). The increase in the number of inhabitants must be accompanied by an increase in the number of habitat modules. The landing, unloading, transportation, and assembly of habitat modules will be an ongoing activity at the lunar base. An increase in the number of inhabitants will also call for an increase in consumables (water, food, oxygen, etc.)

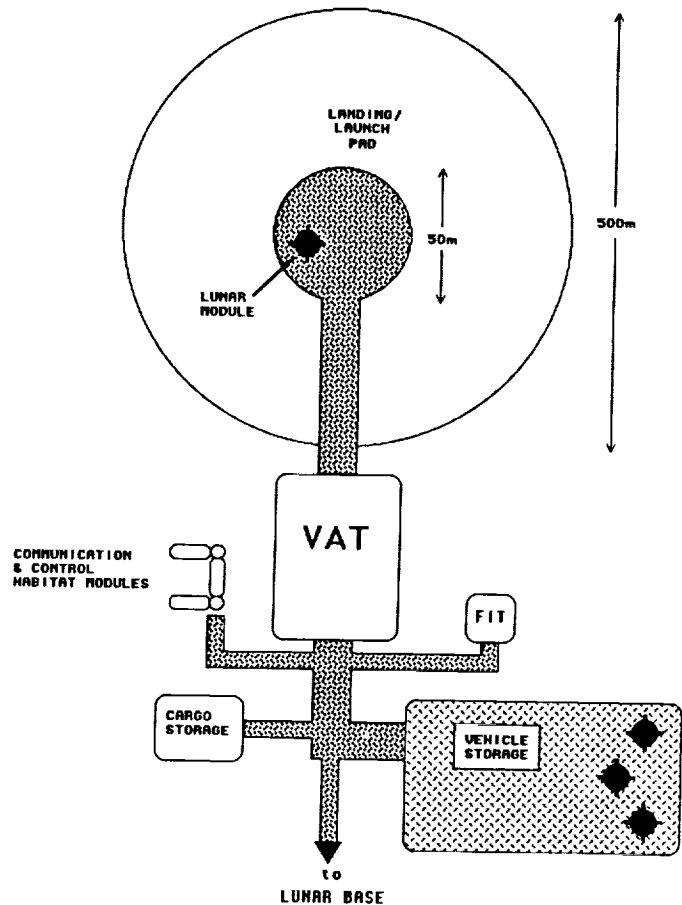

Fig. 3. Complex 39L plot plan.

required. We assume a baseline crew rotation of six months. With a population of 30 this will require 15 lunar module flights per year.

The construction and operation of a lunar liquid oxygen (LLOX) production facility will occur during Phase III of lunar base development (Roberts, 1987; Ride, 1987). As the amount of LLOX exported increases, so must the capacity of the LLOX plant. When the capacity must be increased, another LLOX production module must be landed, unloaded, transported, assembled, and put on line. Each LLOX production module is assumed to have a standard production capacity, and the LLOX plant will be made up of these modules operating in parallel.

The power requirements of the lunar base will increase as the production capacity and number of inhabitants increase. The power available is estimated to range from 1 to 10 mW over the given time period (Roberts, 1987). To meet the increasing demand, nuclear reactors and supporting elements must be landed, unloaded, transported, and assembled. Other supplemental energy sources such as solar energy may also be used with similar installation requirements.

The lunar base subfacilities will be separated from Complex 39L by a specified distance. This distance will depend on safety considerations and the site of the base. The potential of an explosion, large navigation errors in landing, and rocket engine blast will warrant separating Complex 39L some distance from other facilities. An appropriate distance needs to be determined.

Other Considerations

In this section we discuss a number of items that are considered outside the scope of the design, i.e., outside the dashed boundary of Complex 39L as indicated in Fig. 1. Consideration of items being either inside or outside the scope of design follows good design practice (Linsley, 1988).

For purposes of our design, we consider only manned lunar modules. We realize that design requirements for manned as opposed to unmanned vehicles are considerably more stringent and that there will be an effort to use unmanned vehicles to the greatest extent possible. Manned vehicles will also impose more stringent constraints on the design of Complex 39L. The only area where unmanned vehicles will impose more requirements is in the guidance and communications area. These increased requirements can be considered within the margin of error in this preliminary analysis.

It is generally accepted that a high degree of utilization of automation and robotics technology will be used in lunar base activities. While recognizing this, we take many of our design concepts from current technology that has not yet experienced automation or robotics technology advances. Again, this is done partially in the interest of obtaining a conservative design. We also consider that the highly automated and roboticized facilities will be heavily interspersed with rather low-technology devices. Designers of lunar base equipment should look to the seven basic machines of elementary physics for initial design concepts.

A number of advanced concepts have been omitted from this study. We mention two of these. Electromagnetic launchers, which are a popular concept in discussions of lunar base design, are not considered in this Phase III design. Another, less popular, concept that we have considered but omitted is the design of a landing and launch pad from which the recovery of water vapor from the exhaust plume is attempted. We consider these interesting concepts to be beyond Phase III.

MAJOR DESIGN ITEMS

Landing/Launch Site Considerations

The lunar module will touch down vertically on a specified zone (landing/launch pad). For lunar module transportation requirements and dangers from engine blast effects, it is desirable to have a prepared surface. Loose particles on the pad can become dangerous projectiles in the presence of engine blast from the lunar module. With a prepared surface this problem can be greatly diminished. In this study, we assume that the same pad will be used for both landing and launch.

The landing pad will be circular with a diameter of 50 m (approximately four times the diameter of the lunar module). This figure was arrived at by making comparisons with terrestrial vertically landing vehicles. A circular area with a radius of approximately 250 m from the center of the landing pad will be cleared of large rocks and equipment (Eagle Engineering, 1988). The landing area will be marked with lights similar to a terrestrial airport. Also, television cameras will be present to aid the controllers in the communication and control facility. This equipment will be within the 250-m circle, and must be designed to handle any engine blast effects that may occur, e.g., replaceable lens covers on camers. The number of pads will depend on the flight schedule and the time required for maintenance. Figure 3 shows one pad, though more may be required.

Shelter, Structure, Safety, and Environmental Needs

It is assumed that the lunar module will spend a significant amount of time on the lunar surface. This could be from two weeks to two months. It will be desirable to control the temperature of the vehicle by removing it from direct sunlight. This will decrease the boil-off of cryogenes and also provide a more constant thermal environment.

We propose the use of a quonset hut tent-like structure (Fig. 4). This structure will be referred to as the vehicle assembly tent (VAT). The facility will be large enough to contain four lunar modules. The dimensions are 50 m long, 36 m wide, and 18 m high at the center line. Entrances, 15 m high and 16 m wide, will be located at each end of the structure. A framework will be

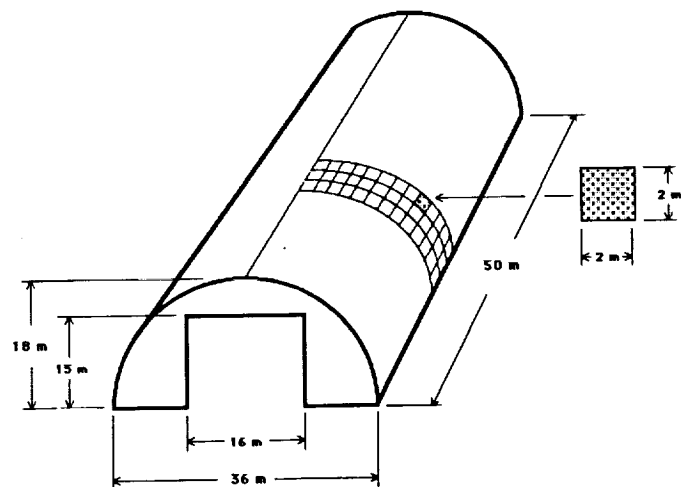

Fig. 4. Complex 39L vehicle assembly tent (VAT).

constructed of a material such as 2014-T6 aluminum (*Aluminum Association*, 1975). Highly reflective panels made of a mylar/evaporated aluminum laminate will shield equipment inside the VAT from incoming thermal radiation. These panels are expected to reflect approximately 90% of the thermal solar spectrum (*Incropera and DeWitt*, 1985). Other panel materials and laminates are being investigated. Initial calculations, with one layer of panels, give a surface-level temperature inside the VAT of approximately 0°C during the lunar day. It was found that using two layers of panels separated by 0.1 m gave a decrease in surface temperature of only 8°C. Movable flaps will be used to cover the entrances at each end of the structure. They will serve to block glare and possible particles from engine blast. These will be made of the same material as the panels. They will cover an area of 240 sq m at each end. A total mass of approximately 10,000 kg has been derived for the proposed structure.

Most servicing and unloading/loading operations will be performed in the VAT. Artificial lighting must be provided where men or video cameras are working. This is not a pressurized facility and personnel must wear spacesuits. This facility will not block radiation that is potentially dangerous to humans. The amount of time humans can work in this environment will be limited (*Adams and Shapiro*, 1985). It may be determined that all surface operations will be best performed during the 14-day lunar night. Electronic devices will also be affected by high doses of radiation in the form of both hardware and software upsets, and should be specially designed for lunar application.

Landing/Launch Guidance, Communications, and Computing Needs

The lunar module will be manually controlled by two pilots. Assistance will be provided by a surface communications and control facility similar to that of a terrestrial airport. It has been determined that currently available terrestrial navigation systems can be applied to achieve high degrees of landing and positioning accuracies, and these systems will be fully operational by Phase III of the lunar base development (*Eagle Engineering*, 1988). A communications and control facility will be located at Complex 39L. Habitat modules will be used to house the operators and equipment. Approximately two people will be required to operate the facility.

Lunar Module Surface Transport System

The lunar module will be transported from the landing/launch pad to the VAT. We envision the use of self-powered dollies. A dolly will be placed under each footpad and the lunar module will be guided to the VAT. It is assumed that the positioning of dollies and guidance of the lunar module will be performed by a person in a spacesuit, though this is an area with potential robotic application that should be investigated. This same system will be used for transporting lunar modules to vehicle storage.

Heavy Cargo Unloading/Loading Systems

Heavy cargo items such as habitat modules, construction equipment, nuclear reactors, and LLOX production modules will be landed at the lunar base on a regular basis. These items will be attached to the lunar module and may or may not be stored in containers. The lunar module will be transported into the VAT fully loaded with payload. Once in the facility the module will be unloaded. We envision the use of a bridge crane. The crane

will encompass an area of 15 m by 30 m at a height of 15 m. For a preliminary design we assume a maximum load of 45,000 kg. We design the center beam to have a deflection less than 0.05 m with the maximum load applied at the center point. It was found that a standard 24 × 62 wide flange beam constructed of 4340 low-carbon steel will meet these design requirements. This is a baseline design and other construction materials are being investigated. We assume that the entire structure will be constructed of the same members. This gives a total crane mass of approximately 20,000 kg.

Operations will begin by detaching (unstrapping) a payload from the lunar module. The crane will then be positioned and attached to the payload. The payload will be lifted, transported away from the lunar module, and lowered onto one or more dollies. If the cargo is not to be delivered directly to its final destination, it will be transported to cargo storage to await further processing. Complex 39L cargo storage will be a separate tent structure similar to the VAT and located nearby (Fig. 3). The lunar module will be loaded in a reverse manner.

Personnel Unloading/Loading Systems

We envision three modes of personnel unloading/loading. The first requires EVA and is similar to that used in the Apollo missions. The personnel will don spacesuits and exit the lunar module by climbing down a ladder that is attached to one of the module legs. This can be done either on the landing/launch pad or in the VAT. If the personnel exit or enter the vehicle on the pad they must either walk or be transported to or from the pad.

The second mode of unloading/loading is for the personnel to remain in the module until it has been transported into the VAT. They will then disembark into the pressurized compartment of a lunar surface transport vehicle. This is a "shirt-sleeve" transport operation where spacesuits are not required. This mode will require a pressurized transport vehicle and an airlock mechanism to connect the two vehicles.

The third mode of unloading/loading is again for the personnel to remain in the lunar module until it has been transported into the VAT. Here, the manned capsule of the lunar module will be detached, lifted by the bridge crane, and placed on one or more dollies. The entire manned capsule will then be transported to the habitat modules where the personnel can disembark through an airlock. This is also a "shirt-sleeve" operation where EVA is not required. A separate pressurized transport will not be required as in the second mode. This example illustrates the integration (modularity) that we believe is necessary for a successful lunar base.

Propellant Unloading/Loading Systems

The lunar module will land at Complex 39L with some propellant remaining in its fuel tanks. Assuming no LLOX is available this will be all the hydrogen and oxygen required for the return flight to LLO. The propellant can either be left in the fuel tanks or transferred into propellant storage tanks. If boil-off from the fuel tanks is large, then it would be preferable to store the cryogenics in larger tanks with active cooling systems. Hydrogen and oxygen storage tanks will be located at Complex 39L. We assume that active cooling systems will be used. The cooling systems will be designed to achieve a specified maximum boil-off.

As a design criterion we require that enough propellant be stored to evacuate the entire lunar base population. For a

population of 30 this would require storage of approximately 150,000 kg of oxygen and 30,000 kg of hydrogen. If one spherical tank is used to store each cryogen, this would require tank diameters of roughly 6 m and 9 m for oxygen and hydrogen respectively. Multiple tanks of differing geometries may be used.

The storage tanks and pumps will be located in a separate tent near the VAT. This tent is referred to as the fuel inventory tent (FIT) (Fig. 3). One method for defueling/fueling the lunar module is to remove the propellant tanks from the module with the bridge crane, place them on dollies, and transport them to the FIT in the same manner that cargo is transported.

Vehicle Storage

A long-term vehicle storage area will be provided at Complex 39L (Fig. 3). This will be an area near the VAT that has been cleared of large objects. At this stage in the lunar base development, we envision an area large enough to contain six lunar modules (approximately 1000 m²). With an increase in the lunar module fleet and landing/launch rate, this area will need to be enlarged.

The lunar module will be transported to vehicle storage if it has been damaged beyond repair, exceeded its operational life, or will not be used for a long period of time. The lunar modules will have been defueled prior to storage. The module will be transported to a storage location as previously discussed. A dome tent will then be pitched over it. This will be a tent made of the same material used in the VAT attached to a support frame. Lunar modules in vehicle storage will be used for cannibalizations. We assume that lunar module components will have varying operational lives. Some components will still be operational when the vehicle as a whole is not. Working components from vehicles in storage will be used to repair operations vehicles in the VAT.

Maintenance, Repair, Test, and Check-Out Requirements

The lunar module is a reusable vehicle and will require regular maintenance with each flight. Unlike presently operated reusable terrestrial space vehicles, the lunar module should have minimal maintenance requirements. For our highest frequency flight schedule (24 flights/year), the lunar module turnaround time will be two weeks (14 days). For a baseline case we assume that routine maintenance will be performed by two personnel. However, more manpower will be required if a significant problem develops or if major systems alterations are required. We identify four main procedures: initial safing, postflight servicing, lunar module modification, and preflight servicing. The following is a preliminary description of some of the operations that will be performed during each of our identified main procedures.

Initial safing will include transportation of the lunar module to the VAT, defueling propellant tanks, attachment of ground power and purge lines to the lunar module, purging main engines and fuel lines to remove possible moisture resulting from hydrogen/oxygen combustion, and unloading payloads. Also, the lunar module crew will disembark sometime during the initial safing procedure. This is a preliminary list of required operations that can easily be expanded upon.

After initial safing is complete, postflight troubleshooting begins to determine anomalies that may have occurred during launch, spaceflight, or landing. An umbilical cord containing electrical, communication, instrumentation, and control lines is connected to the vehicle. Visual and electronic inspections are performed on the lunar module. Along with postflight inspection, routine

servicing will include lubrication, recharging of environmental systems, recharging/regenerating batteries and fuel cells, and others.

Lunar module modifications will then be made if necessary. Modifications will include replacing damaged components, adding or removing equipment to meet future mission requirements, and replacement of outdated hardware/software. Lander modification, if extensive, can be performed over a long period of time while the craft is in vehicle storage. However, many modifications will be performed in parallel with routine servicing.

The lunar module will finally be prepared for launch. Preflight servicing will include installation of flight supplies and payload, fueling of propellant tanks, loading of personnel, final visual and electronic check-out, and transportation from the VAT to the pad.

CLOSURE

We have presented short descriptions or specifications of our nine designated design items. The next stage in our design process is to determine preliminary estimates for the major resource requirements of our system. We identify three major resources to be mass, power, and manpower. The cost of the lunar base will be directly related to the resource requirements. While mass and power requirements can generally be determined by standard engineering methods, assessments of manpower requirements can be difficult. One assumption that is made is that all operations will be undertaken by a minimum of two personnel. This is a safety consideration that mimics the "buddy system" that is used in SCUBA diving.

In addition to our three major resource requirements, we recognize three main resource requirement areas: construction, operation, and maintenance. The construction area represents the resources that will be required during the construction phase of Complex 39L. This will include, but is not limited to, clearing a site, landing/launch pad preparation, pitching of various tents, and assembly of cranes and other structures. The operation area represents the resource requirements for the "steady-state" operation of the facility. The maintenance area represents the facility maintenance requirements, e.g., refurbishment of landing/launch pads, tent structures, and other hardware. More resources and resource areas can be incorporated into this design methodology as the need for greater and greater design detail is required.

Acknowledgments. This work was done under the auspices of the NASA-sponsored University Advanced Design Program through the University Space Research Association, i.e., this has been primarily a senior class engineering project. The Future Projects Office at NASA/KSC has been most helpful. Those who deserve the most thanks are our students.

REFERENCES

- Adams J. H. and Shapiro M. M. (1985) Irradiation of the Moon by galactic cosmic rays and other particles. In *Lunar Bases and Space Activities of the 21st Century* (W. W. Mendell, ed.), pp. 315-327. Lunar and Planetary Institute, Houston.
- Alred J. (1987) *Lunar Transportation Study*. Lunar Transportation Team/ED23, Advanced Programs Office, NASA Johnson Space Center, Houston.
- The Aluminum Association (1975) *Engineering Data for Aluminum Structures*. 750 Third Avenue, New York, New York.
- Astronautics Corporation of America (1987) *Lunar Surface Base Propulsion System Study*. NASA Contract NAS9-17468.

- Eagle Engineering Inc. (1987) *Lunar Surface Operations Study*. NASA Contract NAS9-17878, EEI Report 87-172.
- Eagle Engineering Inc. (1988) *Lunar Base Launch and Landing Facility Conceptual Design*. NASA Contract NAS9-17878.
- Guerra L. (1988) A commonality assessment of lunar surface habitation. Paper No. 85d, AIChE Spring National Meeting, New Orleans.
- Incropera F. P. and DeWitt D. P. (1985) *Fundamentals of Heat and Mass Transfer*. Wiley, New York.
- Linsley J. (1988) Analogies between the design and operations of batch chemical plants and launch and landing facilities. Paper 85h, AIChE Spring National Meeting, New Orleans.
- Ride S. K. (1987) *Leadership and America's Future in Space; Report to the Administrator*. U. S. Govt. Printing Office, Washington, DC. 63 pp.
- Roberts B. B. (1987) *Lunar Bases in the 21st Century: The First Step Towards Human Presence Beyond Earth*. NASA Johnson Space Center, Houston.