

LUNAR BASE LAUNCH AND LANDING FACILITIES CONCEPTUAL DESIGN

N 9 3 - 1 7 4 3 0

Paul G. Phillips¹

*Eagle Technical Services, Inc.
16915 El Camino Real
Houston TX 77058*

Charles H. Simonds² and William R. Stump

*Eagle Engineering, Inc.
16915 El Camino Real
Houston TX 77058*

The purpose of this study was to perform a first look at the requirements for launch and landing facilities for early lunar bases and to prepare conceptual designs for some of these facilities. The emphasis of the study is on the facilities needed from the first manned landing until permanent occupancy, the Phase II lunar base. Factors including surface characteristics, navigation system, engine blast effects, and expected surface operations are used to develop landing pad designs and definitions of various other elements of the launch and landing facilities. Finally, the dependence of the use of these elements and the evolution of the facilities are established.

INTRODUCTION

The likelihood of the establishment of a permanent lunar base has become sufficiently real that serious efforts are underway to mold plans and scenarios for its development. Issues surrounding the facilities needed to support safe and consistent landings must now be addressed to ensure they do not represent primary drivers of the early lunar base. This study was performed to examine the requirements for launch and landing operations and to prepare design definitions for the elements of these facilities. The focus of the study is on the lunar base, beginning at the first manned landing until permanent occupancy. This period of base development has generally been called Phase II, since it is the second in a three-stage process. This paper documents a study of launch and landing facilities done as a part of the Lunar Base Systems Study being performed by the Johnson Space Center Advanced Programs Office.

Requirements and design considerations must be defined generally before concepts for facilities can be developed. The surface characteristics of the Moon will cover site preparation issues, some landing capability requirements, and the degree of autonomy the vehicle must possess. The navigation systems on the flight vehicle will dictate what sort of navigation support must be provided by lunar base facilities. Another type of interaction with the flight vehicle, the effects of blast from the rocket engine, defines requirements for many aspects of facilities designs. Finally,

the expected general operations of the base and its landing facilities must be described to provide a framework for selection of what elements must be designed.

Once the elements of the launch and landing facilities have been defined, they can be fitted into more specific plans for the lunar base. The growth and evolution of launch and landing facilities will naturally be coupled with the growth and evolution of the lunar base itself. To complete the conceptual design, the dependencies between these base and launch and landing facilities must be defined. These dependencies can be used in the future in planning the lunar base.

SURFACE CHARACTERISTICS

The first task in the definition of landing facilities is the characterization of possible base locations. These site characteristics have general effects on the design requirements and setup operations of landing facilities. The characteristics of interest are surface roughness, soil mechanics data, lighting, and Earth visibility. Given its age, the lunar surface is fairly homogeneous in many respects. Landing pads can be designed without regard to base site.

Roughness

In general, landing sites with relatively low slopes of 4° to 6° for 25-m ranges can be found over the entire lunar surface. Some locations, such as the sides of large craters and mountainsides, may have unacceptable slope characteristics. Mountainside slopes of around 30° are not uncommon. Data on the roughness of the surface comes from several different sources:

1. Photogeologic terrain assessment is the first and most straightforward. This simply involves assuring that candidate landing sites do not lie on the sides of mountains.

¹Now at Science Applications International Corporation, 17049 El Camino Real, #202, Houston TX 77058

²Now at Lockheed Life Support Development Laboratory, Mail Code A23, 1150 Gemini Avenue, Houston TX 77058

2. Photogeologic measurements of slopes based on high-resolution vertical photography taken from lunar orbit provide slope distributions. Published data is available for all the candidate Apollo landing sites, as well as other areas of the Moon. Figure 1 shows some of these data.

3. Counts of the number of impact craters in a series of size classes based on high-resolution vertical photography taken from lunar orbit provide general roughness data. Figure 2 presents a summary of crater counting data before the Apollo 17 mission (*Minutes of Apollo Site Selection Board, 1972*).

Soil Mechanics

Bearing strength, slip resistance, and grain size are important characteristics when landing surfaces are considered with respect to landers. Strong variations are generally not found over the lunar surface, indicating that landing pad preparation and lander foot pads and legs may be designed without regard to specific base sites. Considering Apollo experience, landers can be designed for an unfinished surface.

The lunar surface consists of a fine-grained soil with over half the material finer than 0.075 mm (*Mitchell et al., 1973*). Table 1 summarizes other soil physical properties for the Apollo 14 through 17 landing sites. For reference, the Apollo lunar module placed a stress on the surface of about 0.69 N/cm². Such stresses resulted in penetrations of the lunar surface of less than a centimeter in firm soil to a few centimeters in soft soil. The angle of internal friction of lunar soil is equivalent to the angle of repose for loose soil such as on the side of a mountain. The tangent of the angle is equal to the coefficient of internal friction, 0.73 to 0.90.

Earth Visibility

The visibility of Earth from the selected base site will affect the degree of autonomy of the lander and its interaction with the landing site. The ability of vehicles to receive Earth-generated navigation updates will influence the need for lunar-based navigation systems. Continuous, real-time communication with Earth is highly desired. Earth support of most operations will be required to make the best use of crew time on the lunar surface. The effects must be described for each specific landing site.

Sites on the limb of the farside will not present good opportunities for updates without prior placement of either surface or space-based relays. The western limb does allow

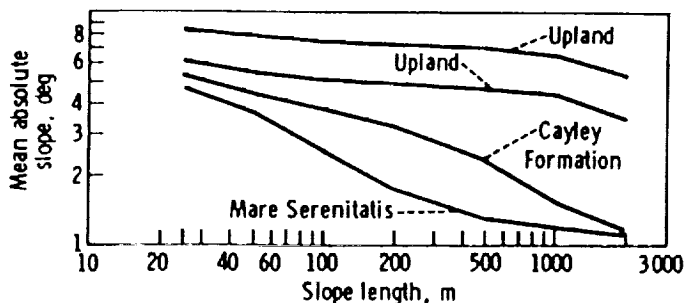

Fig. 1. Lunar slope-frequency distribution (*Moore and Tyler, 1973*).

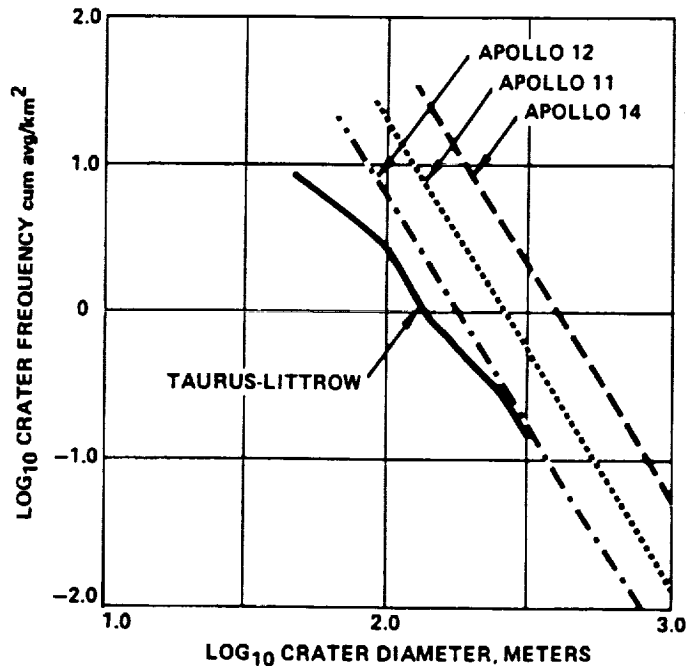

Fig. 2. Size distribution of lunar craters.

considerable Earth tracking of landers in the initial parts of the descent, but final descent will generally be invisible to Earth systems.

Lighting

Lighting mainly affects the time crew-controlled landings may occur for most sites. Polar sites, however, have continuously low solar angles and landing systems, especially during early missions, and must be able to handle hidden features and long shadows. Again, these effects must be analyzed with respect to each particular site.

NAVIGATION SYSTEMS

Flight operations are intended to result in landings with meter accuracy. One of the primary purposes of the landing facilities and the equipment they encompass is to ease flight vehicle operations from orbit-to-surface and surface-to-orbit descent and ascent.

During descent, flight vehicle navigation and guidance systems must be provided position updates, and during final stages of landings must be able to find relative positions and velocities to within accuracies of meters. In particular, unpiloted cargo landers will require this level of accuracy to land on a specific site. The vehicle inertial platforms should be updated on the orbit before descent and then continuously from the time of descent to landing.

The navigation systems provided as part of the lunar base landing facility may be relatively simple systems of radar transponders with known locations. Onboard systems will use terrain- and feature-matching systems, similar to those used by current cruise missiles, during periods when the base is out of view. In short, the navigation systems can use currently available terrestrial systems applied to the lunar surface to achieve high degrees of landing and positioning accuracies.

TABLE 1. Soil properties.

Soil Consistency	Mechanical Data					
	G N/cm ³	Porosity	Void ratio, e	D _r	Φ _{TR}	Φ _{PL}
Soft	0.15	47%	0.89	30%	38°	36°
Firm	0.76 to 1.35	39% to 43%	0.64 to 0.75	48% to 63%	39.5° to 42°	37° to 38.5°

G = penetration resistance gradient; D_r = relative density = $(e_{\max} - e) / (e_{\max} - e_{\min})$, based on standard ASTM methods; Φ_{TR} = angle of internal friction, based on triaxial compression tests; and Φ_{PL} = angle of internal friction, based on in-place plate shear tests. From Mitchell et al. (1973).

TABLE 2. Navigation system advantages and disadvantages.

System	Advantages	Disadvantages
Lunar Orbit Global Positioning Satellite (GPS) type system.	Terminal, perhaps landing accuracy navigation over entire surface.	Many satellites required. Expensive to place. Accuracy limited. Not adequate for touchdown navigation.
Earth-orbit GPS system or Earth-based radar.	Nothing to place or power on lunar surface. Good for orbit determination on the nearside.	GPS accuracy unknown. May require large antenna. Earth side only.
Long and Medium Range Lunar Surface Transmitters: TACAN, LORAN, low frequency.	Several low-frequency transmitters may provide low-accuracy global coverage. Can be placed and powered at base for local navigation and orbit updates. Terminal accuracy.	Heavy ground stations. Large antennae. Accurate over a limited range only. Low frequency does not provide high accuracy for any location. Low-frequency global coverage requires several transmitters at different places.
Instrument Landing System or Microwave Landing System at base.	Can be placed and powered at base. Landing accuracy.	Terminal and landing navigation only for area close to transmitter.
Lunar Surface-Based Radar (located at base).	Enables range safety thrust termination. Can provide updates to vehicles in orbit. Low mass system.	Local area navigation only.
Cruise missile type onboard terrain matching radar on lander with transponders on surface.	Transponders only on surface in landing area. Very low mass. Landing accuracy navigation probable over entire surface.	Landing accuracy depends on accuracy of surface feature maps.

The Apollo landers used a combination of Earth-based radar, crew recognition of local features, space sextant work, and inertial navigation to achieve an impressive accuracy. In addition, the vehicles had radar altimeters, and radars measured relative velocity. The radar altimeter was used to determine certain checkpoints later in the program. The crew always did the landing navigation visually.

Table 2 shows a variety of possible systems for updating the onboard inertial system and accomplishing landing navigation, including the terrain matching and transponder system. The advantages and disadvantages of each are discussed. All these systems can be related to similar Earth-based systems.

ENGINE BLAST

The effects of engine exhaust blasting the lunar soil are far reaching. Blast from the lander engine will affect virtually every aspect of lunar base design. While the effects will not present insurmountable problems, serious consideration must be paid to

them in the design of nearby facilities. The distance between the landing pads and surface facilities and equipment, especially the base itself, will depend on how far away blast damage can occur. The design and protection of equipment that must remain in the vicinity of the landing pad will be governed by how serious the damage from blast will be. When permanent reusable landing pads are needed, the stabilization of those pads will depend on the expected impingement of engine blast.

In addition to being far reaching, blast effects are probably the single most complex to analyze of any affecting pad designs. The analysis prepared for this study was a rough order of magnitude calculation. Many assumptions and simplifications were made. Where needed, they were made as conservatively as possible. Comparison to known data and effects were made where information is available. The nature of the rocket plume was quantified using data provided by Alred (J.W. Alred, personal communication, 1982). These data characterize the exhaust plume of a small engine that is scaled up to an engine the size of the 50,000-N lunar module (LM) engine. The effects of

backpressure were not included. Calculations are broken into four sections: (1) lofted particle sizes; (2) lofted particle trajectories; (3) particle flux at a distance; and (4) particle damage.

Lofted Particle Sizes

Lofting of surface particles is assumed to occur by stagnation of plume flow directly under the particle. The vertically upward force resulting from this pressure is balanced against the vertically downward gravity force and the angled drag force caused by direct impingement of the plume. Maximum particle size for the landed configuration is 5 mm. Particles in the 75 μm or less category, which make up 50% of the soil, can be lofted from a lander altitude of 15 m to 20 m. This is generally consistent with Apollo data, which show that dust usually first appeared at 15 m. Variation of the maximum sizes with respect to thrust variations is nearly linear. A fivefold increase in thrust to 250,000 N shows that rocks of up to 25 mm may be lofted, although they do not go far.

Lofted Particle Trajectories

Particle trajectories were found by assuming that ejection of particles occurs by direct drag acceleration of particles in the plume. The ejecta trajectory calculations from the baseline engine show the maximum distances and velocities shown in Table 3.

Figure 3 shows graphically the ballistic trajectories of the particles after they leave the plume. The trajectory data are generally consistent with the findings of *Cour-Palais et al.* (1972), which, based on Apollo 12 and Surveyor interaction, indicate that particles with velocities in the neighborhood of 100 m/sec were ejected from the engine blast. Increases in thrust result in roughly linear increases in distance and velocity increases that are proportional to the square root of thrust increase.

TABLE 3. Landing blast ejecta.

Particle Diameter (mm)	Impact Distance (m)	Impact Velocity (m/sec)
4.0	20	10
2.0	40	15
1.5	50	20
1.0	75	25
0.5	150	35
0.25	325	50
0.075	1200	100
0.050	2000	125

Particle Flux

Particle flux will obviously vary with the inverse square of the distance from the lander. The original flux was calculated assuming a percent surface obscuration due to particles and converting this to a number of some sized particles. The calculations were made using 50- μm particles and 50% obscuration. This provides conservative estimates of the number of surface impacts due to ejecta flux. In general, at 50 m over 30,000 particles per cm^2/sec can be expected. If larger particles are included, fewer impacts can be expected. At 200 m the flux drops to around 2000; at 2 km the flux is below 50. The flux will vary with the square root of power increase, so a fivefold increase in power will only roughly double the flux at a fixed distance.

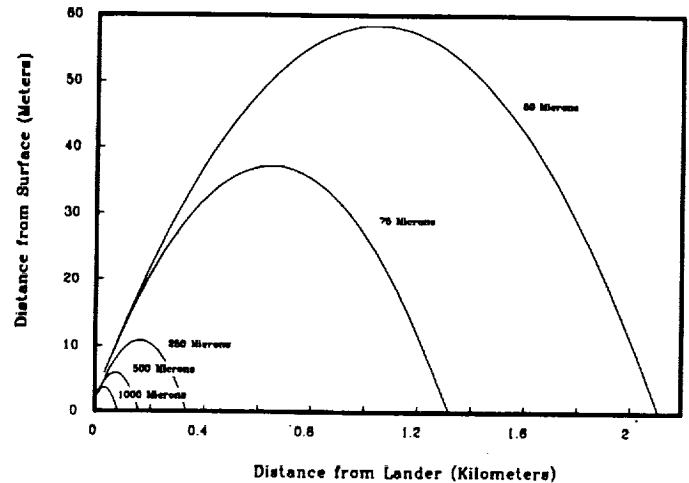

Fig. 3. Lofted particle trajectories.

Particle Damage

Finally, particle damage to surface facilities and equipment can be assessed using the calculated flux, velocity, and size data. Cratering by the low velocity impacts can be studied with known relationships such as those presented in *Wilbeck et al.* (1985). For the purposes of this study, cratering by ejecta on aluminum and glass surfaces was considered. To evaluate net effects of impacts on surfaces, the flux of 50 μm particles calculated above was used. A typical final 10-m descent should last approximately 5 sec. Combining this with flux data, the number of impacts per landing can be found. From crater diameters, surface areas of each crater may be established; thus, the percent of the surface area pitted by craters for each landing can be established. Figure 4 presents the effects for both surfaces with respect to distance from the landing event.

At 50 m an aluminum surface can be expected to have about 5% of its area covered by pits after one landing. This generally will not affect surface properties unless high reflectivity is needed. Glass at this same distance can be expected to have all of its surface pitted. Generally speaking, this will ruin optical-quality glass surfaces. Some pits resulting from bigger ejecta could achieve depths as high as 0.1 mm, easily visible to the naked eye.

At 200 m, about 0.5% of an aluminum surface will be pitted. This is only minor damage. If degradation of the surface radiative properties is not at issue, aluminum surfaces should not present problems even after numerous landings. Glass, however, can have as much as 10% of its surface pitted after a single landing event. For optical instruments, this will be unacceptable. Pit depths of 0.03 μm are possible. This would not ruin vision glazing until several landing events had taken place.

At 2 km, the aluminum surface will sustain virtually unnoticeable damage. Reflective surfaces will degrade after numerous landings and should be protected. Glass surfaces will sustain about 0.1% surface pitting. This will be unnoticeable in vision glasses after a single event but may show up as haze after several landings. Optical-quality glasses should certainly be protected.

SURFACE OPERATIONS

During early operations, landing facility activity will be coupled closely with overall base operations. Lunar surface operations will use the lander/ascent vehicle as a hub, and crews will live in the

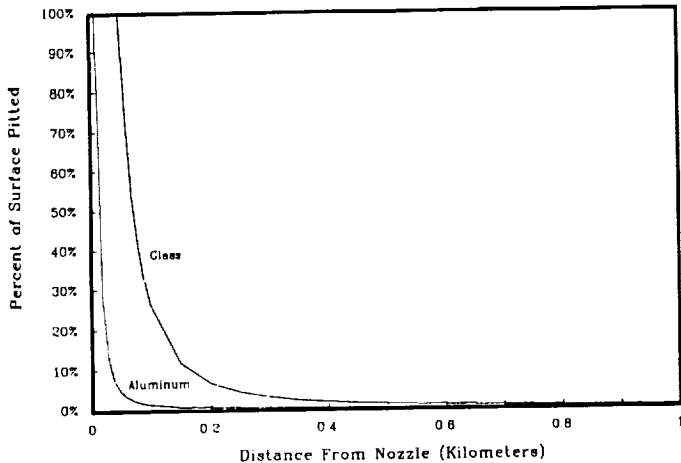

Fig. 4. Single-event surface damage.

vehicle. Because of this, the landing pads will tend to be as close to the base as possible. The first crews will arrive on the lunar surface and select or verify a base site with an area suitable for landings nearby. They will place remote navigational aids and lay out the additional pads needed. The number of pads will actually depend on the scenario, but it should be sufficient to handle all landings up to and including the next piloted mission. Subsequent crews will do the same, except they will not need to place the remote navigation aids. Vehicle off-loading will take place when appropriate according to mission plans. When each crew leaves, sensitive surfaces and equipment installed at the base will be protected from the blast of the next landings as appropriate for each case.

The general area of the temporary pads will be selected by crews near the end of the early landing site development stage. They will move the remote markers at the same time to accommodate the new landing location. Each crew will lay out at least a sufficient number of landing pads to accommodate all the missions up to and including the next piloted mission. To minimize the effects of blast and to eliminate danger to base facilities from landing errors, the pads will be located away from the base. Mission planning may indicate that all temporary pads may need to be marked during one mission. Crews will move to the base after arrival on the surface. Until pressurized transfer from vehicle to base is available, EVA will be needed to get crews into the base. This will necessitate careful mission planning to ensure that every EVA hour is used appropriately. Since the stay times for a temporarily occupied lunar base may be significant, the vehicles must be provided with survival support including power to operate systems, supplemental cooling to accommodate the extra loads from the lunar surface, and meteoroid protection. Crews will unload cargo vehicles as indicated by the mission plans. When each crew leaves, they will protect the equipment left behind near the pads, such as surface transportation vehicles, from the blast of the next landers. In addition, some of the equipment, instruments, and facilities left at the base may need protection.

At the end of the temporary stage, the best site will be picked by the crews, and the pads will be leveled and stabilized. These pads will be marked using the standard markers. Since the temporary and permanent pads will be close together, the remote

markers may be left where they are. Depending on the availability of pressurized transfer, the crew may or may not need EVA to get into the base itself. In addition to offloading vehicles, the reusable pads will need to be cleared of empty cargo vehicles and expendable lander platforms. Piloted vehicles will be provided with survival support for the long stay on the surface. Some vehicles may require loading and servicing. The activity of the crew as they leave the lunar surface will depend on whether the base is permanently occupied or not. Temporary occupation will indicate the same preparation as needed for the temporary stage. Permanent occupation indicates the same sort of preparation but may also require suspension of some ongoing activity such as EVA operations.

FACILITY ELEMENTS

From examination of the surface operations, the elements needed for the launch and landing facilities may be ascertained. Many of the elements used as part of the launch and landing facilities will be used to support other lunar base operations. In general, these relate to transportation of crew and cargo and to construction-related activity such as surface grading and equipment handling. Some elements are truly unique to the launch and landing facilities. The elements of the launch and landing facilities described in the following section are generally unique to the facilities.

Landing Pad

The most obvious and indeed most important of the site facilities is the landing pad itself. Two basic types of pads must be designed: permanent reusable pads for later base development stages and nonreusable, unprepared pads for early use. Several issues combine to define the degree of surface preparation and refurbishment needed, the size and configuration of the landing pad, and the distances at which other base elements must be kept.

The stage of lunar base development affects two aspects of landing pad design: pad preparation and pad location. Unprepared nonreusable pads are appropriate during early stages of base development when surface crew time is at a premium. The maximum distance between the base and landing pad is 250 m to 400 m before base habitation is possible, since crews must be able to easily walk between the vehicle and base site. After base habitation and until highly reliable surface transportation is available, the base and landing area must be within maximum crew walking range, so 3 km to 5 km is the maximum separation distance.

Surface slope and obstacle characteristics affect the degree of landing pad preparation required. Landing area selection efforts, the degree of pad preparation, and lander capabilities can all be traded against each other. As a first-order discussion of these trades, the Apollo lander capabilities will be assumed. Lunar base site selection must be done for an area at least large enough to handle all planned landings as well as gross navigation errors. This area may be as large as an ellipse 14 km by 6 km or greater, typical of Apollo missions. Unprepared landing pads can be located within this area with only modest amounts of *in situ* inspection by crewmembers. Adequate sites were found by Apollo astronauts within several minutes from some 10 km away while the LM was in flight. When precise alignment of surface systems with vehicle systems is required, level landing pads are needed. For example, placing a large cargo in a set of trunnion attachments will require significant alignments. If the series of fittings is not near

horizontal, proper attachments to all fittings at one time will be difficult, time consuming, and dangerous due to the possibility of cargos coming loose. Significantly off-horizontal landing configurations may present unacceptable requirements for cargo loading and vehicle servicing equipment.

Landing errors affect the size of the landing pad and the distance between the pads and base. Landing pad size should be about 100 m across. The Apollo nominal 3σ landing areas were about 2000 m across, assuming good navigation system updates from landmark recognition and Earth-based tracking. The additional aid of site-originated, precise, and continuous navigation system updates will be available for lunar base landings. This precise position data coupled with the maneuvering capability experienced in Apollo 17 should easily allow the 3σ landing area to be reduced by an order of magnitude to 100 m. There is a risk of the vehicle landing in an area 100 m from the target landing spot. Consequently, equipment and facilities located within 150 m to 200 m of the target are at risk of the same damage they would experience if they were located on the pad itself. Because of this risk, the base and related equipment should be at least 200 m to 250 m from the landing pad. During later stages the landing pads should be at least 3 km away from the base to remain outside the landing ellipses.

Lander and pilot visual and radar resolution will mainly affect the distribution of pad markings. Markings may be placed at the apexes of a triangle inscribed within a circle 100 m in diameter. The placement of three pad markings on this circle in a triangular pattern will result in separations of about 90 m. This presents a 1° separation at 5 km and should provide adequate resolution for final approach and landing sequences. Apollo landing operations only allowed direct line-of-site viewing at 8 km. This should be sufficient for piloted landings and present little or no problems for radar guidance, assuming transponders are provided.

Blast effects will dictate the distance between the landing pads and surface facilities and equipment, especially the base. The interaction of the blast with the lunar soil was described previously. From 0 m to 50 m, metal objects will experience significant surface damage, and glass surfaces will experience severe damage. From 50 m through 200 m to 400 m, metal objects will experience only minor pitting after one landing, while glass surfaces will experience significant damage. From 400 m past 2 km, metal objects will sustain only very minor and probably unnoticeable pitting damage after numerous landings. Glass surfaces will sustain minor damage after numerous landings. The damage will eventually be unacceptable for optical-quality glasses. Optical instruments should face away from landings.

The conceptual designs of the landing pads resulting from accommodation of these issues are shown in Figs. 5 and 6. A reusable pad will have a flat, leveled and stabilized surface inside a 100-m diameter. Surface stabilization techniques will be described later in this report. The pad will be marked by three markers on the circle. The slopes within this area should be as close to 0° as is practical and certainly not over 1° . These slopes will allow easy alignment between surface and flight vehicle systems so complex surface support activities can take place. An area 200 m in diameter should have slopes not greater than 4° so that small dispersions can be accommodated with little off-nominal surface support efforts. Usable items should be outside a 250-m radius to prevent damage from stray ejecta that may break away from the pad. The pad should be located 3 km from the base to accommodate 3σ landing dispersions determined for gross navigation update failures, for crew safety during permanently occupied operations, and to minimize blast effects on the base.

An unprepared pad will be of the same dimensions and markings as the reusable pad. Slopes of 6° over 20-m distances, and 1-m humps and depressions are acceptable. Boulders over

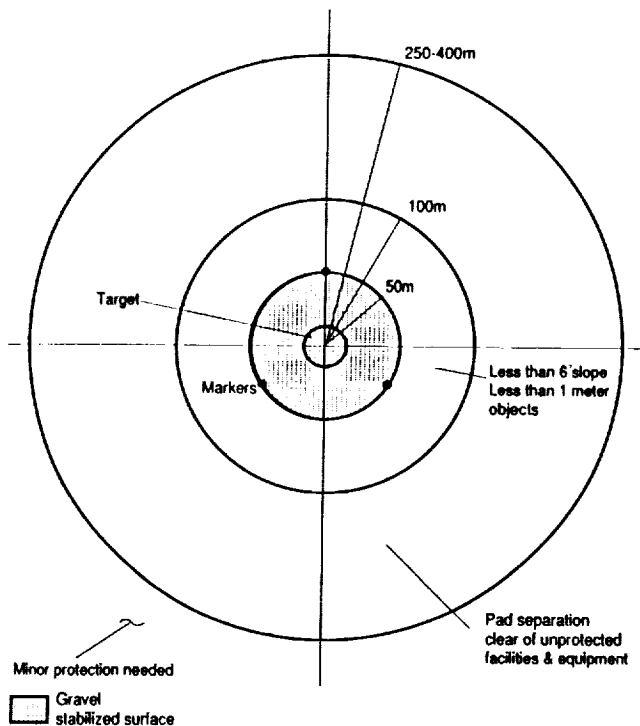

Fig. 5. Permanent landing pad.

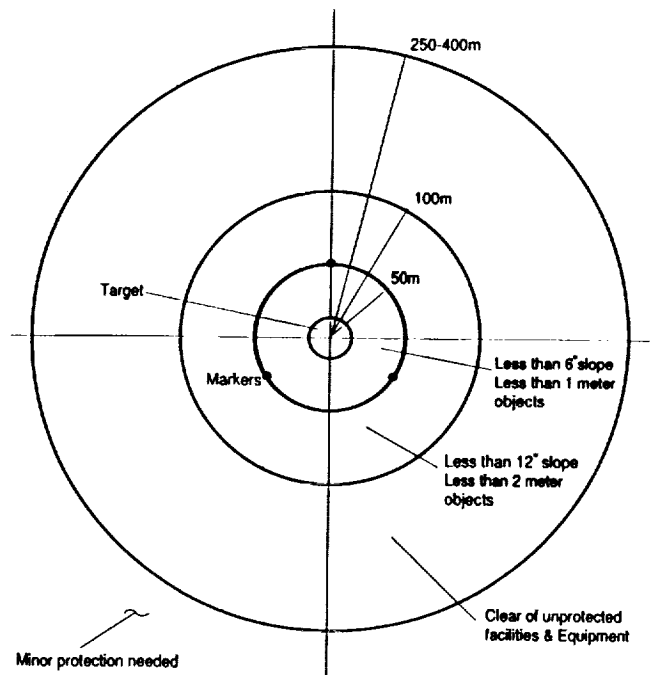

Fig. 6. Unprepared landing pad.

about 0.5 m should be eliminated or avoided to provide footpad stability and clearance for descent engines. The 200-m area should have no slopes over 12° and no humps or depressions over 2 m in relief. Slope restrictions are based primarily on landing stability limits in this case instead of surface support interface requirements. Pads may be located as close as 250 m to 400 m from the base and each other. However, at these distances precautions must be taken to protect reflective and optical surfaces on base equipment. When the base can support habitation, the pads should be located 3 km from the base. In addition to accommodating safety and navigation errors, this distance relieves some of the facility and equipment surface protection precautions.

Surface Stabilization

Surface stabilization will be required once the conditions for the establishment of reusable landing pads occur and area grading has been accomplished. This stabilization reduces the amount of pad refurbishment required between landings, reduces or eliminates ejecta, and provides easier surface transportation and more consistent roadway surfaces. There are several methods for stabilizing the lunar surface. Paving tiles, gravel, and simple compaction represent three methods of various degrees of complexity of the setup equipment and operations, and the extent of maintenance operations. The results of these trade-offs seem to indicate that deposition of either natural gravel or man-made gravel is the best surface stabilization method.

Paving tiles, depending on the tile design, offer the best overall surface. Maintenance of the surface is virtually nonexistent, but paving tiles are very difficult to set up. Simple compaction, at the other end of the spectrum, offers the lowest quality surface. Even though soil cohesion is high, fine particles are still exposed to lander blast and to wheeled and foot traffic. This will eventually result in blast ejecta and dust problems.

In addition, maintenance of surfaces will be the same as initial setup operations, since the surface will require releveling and recompaction after exposure to traffic. Finally, gravel provides a good, although not superior, surface. The surface is not as stable or easy to travel on as paving tiles, but fine soil particles are not exposed to lander blast or surface traffic. Proper selection of gravel sizes should provide roads and pads that are well within acceptable specifications. Gravel is readily available from natural screening or as a by-product of the resource utilization processes, which will just precede the need for stabilized surfaces. Leveling and spreading of gravel surfaces can be accomplished easily by the same operations used for leveling the surfaces below them. Maintenance may involve periodic leveling of gravel surfaces, but these operations should be minimal if gravel sizes are selected appropriately. In short, gravel deposition surface stabilization provides adequate surface characteristics without the need of any significant unique equipment and without the need for exotic operational activity. Figure 7 shows the three types of stabilization.

Blast Barriers

Blast barriers are used to protect equipment from the effects of the ejecta from the landing events. There are two primary philosophies for the design of these barriers. First, blast barriers can be erected as permanent structures close to the landing pads. Second, smaller temporary or permanent structures can be erected at individual equipment locations to shield small areas from the effects of the ejecta. Examination of the nature of the blast and the effects of small off-nominal landing conditions

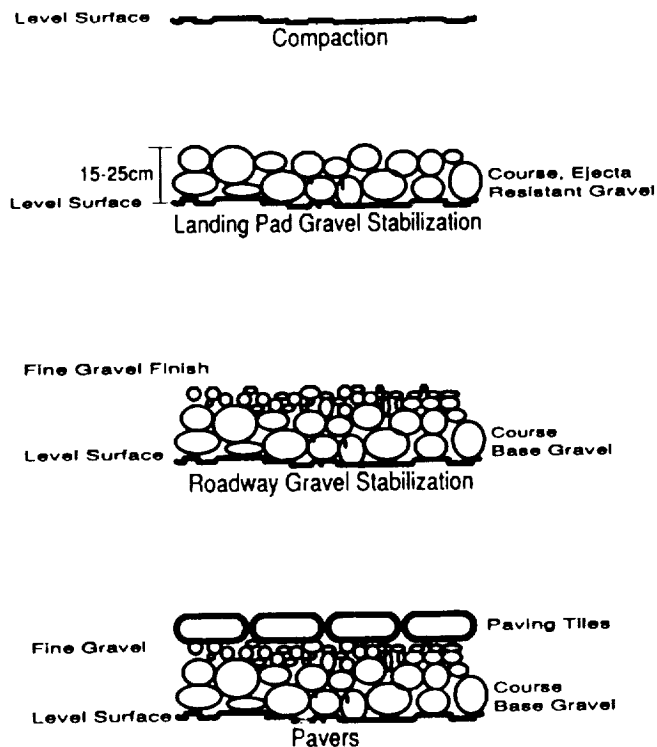

Fig. 7. Surface stabilization.

indicate that the second philosophy of protecting equipment and facilities is the most desirable. Figure 8 shows some of the methods of local blast protection.

Close barriers must be tall enough to block the bulk of the particles and yet must be far enough away so as not to represent hazards for off-nominal landings. Blast calculations above indicate that at 50 m, maximum particle altitude is 7 m, and at 100 m particle altitude is 12 m. Barriers 7 m to 12 m high are major items. With these heights, it is safe to assume that the barriers must be made from local resources such as piles of soil or gravel. A soil barrier 12 m high, beginning at 50 m and peaking at 100 m, will have a slope of 13° (only marginally acceptable) and will be a considerable construction project.

Local equipment and facility barriers appear to provide easy forms of surface protection for modest efforts and minimal weight penalties. Several methods are available depending on the particular application. First and most simple is careful orientation of equipment so that sensitive surfaces face away from the landing. If this proves unfeasible because equipment cannot be moved, installation of a barrier will be needed.

For glass surfaces, two methods may be considered. If the surface must be used to view the landing event, double glazing should be used such that the outer layer is easily replaced once surface erosion has progressed too much. If the viewing is not needed during the event, a movable opaque shield can be installed. This could consist of thin plastic or aluminum sheets.

For equipment with complicated geometries and extensive sensitive surfaces, covering by a blanket or erection of a vertical barrier may be used. Blankets of mylar or lightweight fabrics provide the simplest method of protecting sensitive equipment that is not used without crewmembers. A shield such as metal

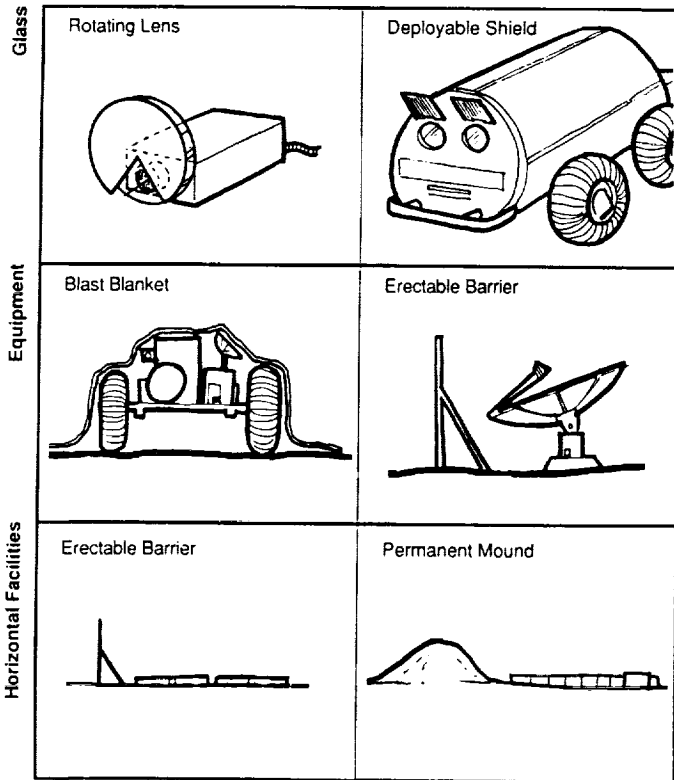

Fig. 8. Blast barriers.

plate or fabric stretched on a frame of suitable size can be easily leaned against or propped next to equipment that must remain active during the absence of crew.

Pad Markers and Navigation Aids

Pad markings and navigation aids are present to assist flight crews and automated landers in locating the landing pads and in adjusting trajectories to ensure precision landings. Visual marking is intended to provide identification of the pad to the crew for piloted missions. Navigation aids are intended to provide visibility to automated guidance systems.

Figure 9 shows one possible device to serve as a pad marker with a radar transponder. The marker should have stowed dimensions of 50 cm x 50 cm x 10 cm and a mass no greater than 10 kg. The device contains a transponder, a visual marker, and a laser range finder. These markers are placed at three positions on the 100-m diameter of the landing pad as discussed for the landing pad design. In addition, two of these markers are placed at about 1.5 km downrange and 1.5 km crossrange from the landing site. The two will be visible above the horizon, both from each other and from the landing pad. These long-range transponders provide detailed navigation data to the lander guidance system. They will show 1° separation at 90 km at which point the base will be visible to the lander and the lander will have plenty of time to make needed course corrections. Three markers are needed for each pad along with the two downrange and crossrange. Each crew will generally set at least two pads for a subsequent cargo and piloted landing. As a result, the first crew

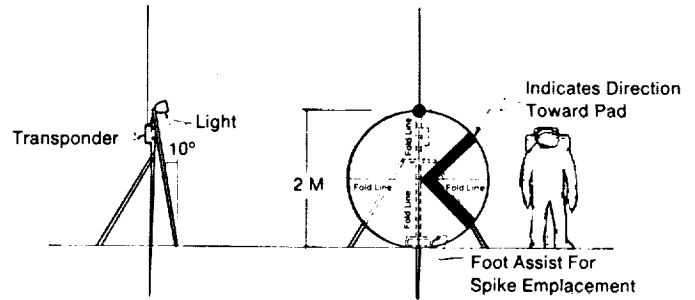

Fig. 9. Landing pad marker.

will need eight markers. The two long-range transponders will be set once and left in place. The three pad markers will be set each time a pad is selected, whether for unprepared pads or reusable pads.

Crew Access

Methods for transferring crewmembers to and from vehicles can be extremely simple. The initial method will be via extravehicular mobility units (EMUs) already carried by crews for other purposes. This method will be considered the trivial case, since only a ladder will be needed. Of primary interest is transfer between two pressurized spaces. The employment of IVA transfers will relieve operational issues such as mission planning for EVA on the first and last days of the surface stay.

Several concepts are available for accomplishing pressurized transfers including rigid and flexible tunnels, systems fixed to either the lander or the pressurized surface vehicle, and independent systems. One concept involves a dedicated ramp vehicle similar to the mobile stairways used for airline passengers. The difference is that the lunar version would be pressurized. After the landing, the ramp approaches and connects to the landed vehicle. Soon afterwards the rover vehicle attaches to the other end of the ramp. Crewmembers then pass from the lander to the rover, reseal the ramp, and depart for the base.

Figure 10 shows one concept for a ramp-type transfer tunnel. The tunnel ramp is basically a trailer with a special pressurized tunnel and universal docking adapters/hatches at both ends of the tunnel. The tunnel ramp is estimated to have a mass of about 3 t. The wheels will be powered so that the ramp may be operated independently. It can either be controlled by connection to the pressurized rover itself, or it may be teleoperated. The ends of the tunnel are flexible so that it can mate with the uneven docking adapters of the lander and rover. It is anticipated that the height difference between the rover and the lander hatches will be approximately 2 m from center to center.

Cryogenic Transfer

Cryogenic storage equipment is needed for resource utilization activities in which liquid oxygen or hydrogen is produced in quantity on the lunar surface and is used in off-surface operations. Options for transfer could involve either permanently installed lines from storage equipment to pad locations or transfer vehicles with tankage for transfer. Since the vehicle needed for transfer can also be used for filling the storage facilities from plant

supplies, vehicles can easily be designed to have the same connections. Installation of permanent lines to each pad will be major operations and beyond a Phase II lunar base.

Figure 11 illustrates a propellant refill vehicle (PRV) that represents one concept for performing fuel transfer. The PRV consists of a storage tank for either liquid hydrogen or liquid oxygen, the necessary support equipment to transfer the fluid to a flight vehicle, and the required hardware to run the vehicle. The

PRV is used for filling and draining dedicated tanker vehicles with fixed tanks, filling propellant tanks of a reusable vehicle, and scavenging unspent fuel from landers.

The propellant tank for the PRV is 3 m in diameter and has a 3-m long cylinder with spherical ends. This allows it to carry 35 cu m of propellants, which is equivalent to about 2500 kg of liquid hydrogen and about 40,000 kg of liquid oxygen. A boom with flexible propellant lines is included with the PRV to

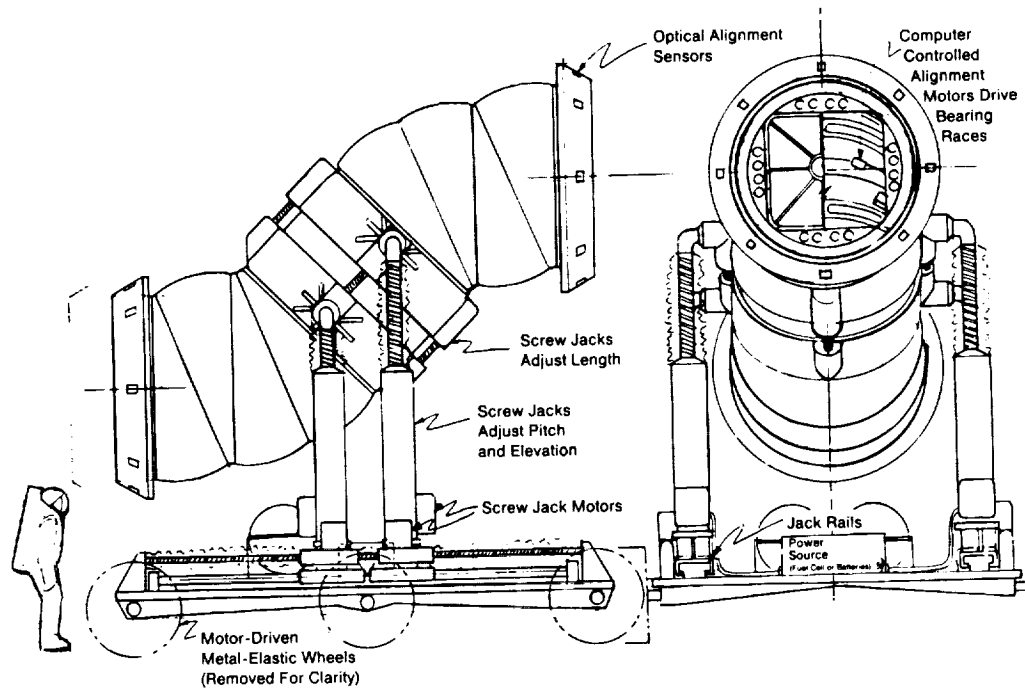

Fig. 10. Crew transfer tunnel.

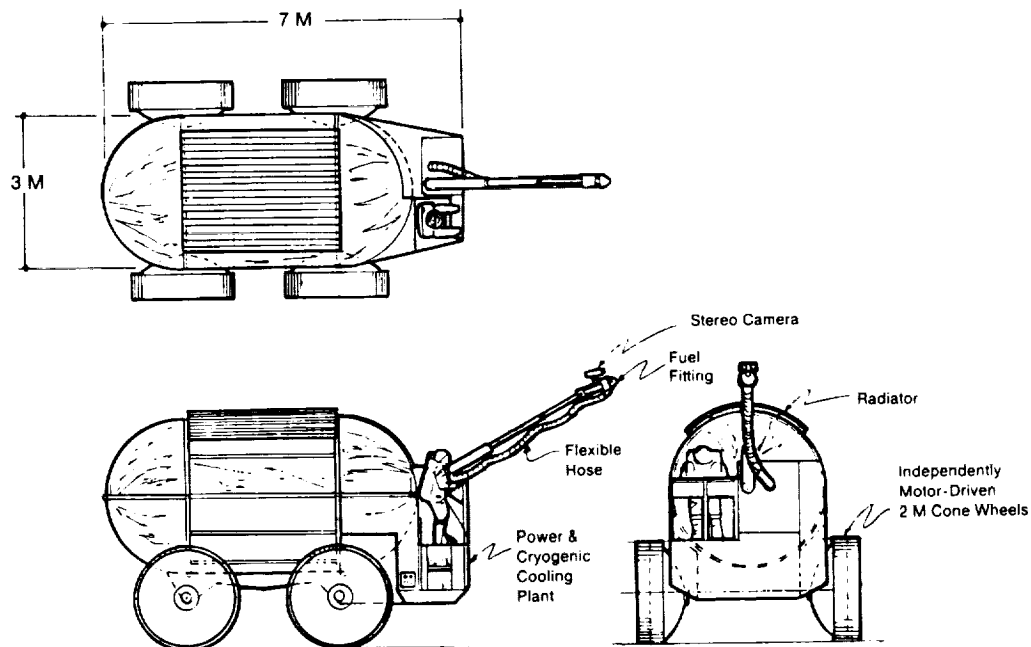

Fig. 11. Propellant refill vehicle.

accomplish fluid connections. The base of the fluid transfer boom is anchored to the front deck of the vehicle. The crewmember is situated at the base of the boom from where he controls boom positioning during propellant transfer maneuvers or controls the vehicle while traversing to the landing site. The fluid transfer nozzle is positioned by rotating the boom base and extending the telescoping boom elements. For accurate positioning, fine adjustments are made at flexible joints near the nozzle before mating to the lander. While the PRV is in motion, the boom is stored in the collapsed position.

No serious attempt has been made to find the mass of the PRV, but estimates are that it will mass 14,000 kg empty. This includes an estimated 10,000 kg for the tank, 2000 kg for the structure, power, locomotion, and other subsystems, and about 2000 kg for the refrigeration and radiator system.

Power Supply

Electrical power is a vital utility for piloted vehicles on the landing pads. The vehicle systems must be kept in working order, and appropriate overall vehicle thermal conditions must be maintained. Although these vehicles will have their own onboard power systems, the lunar environment is significantly different from that of space, and mass considerations may limit electrical energy storage capabilities. Without performing detailed study, it is evident that some sort of supplemental power supply for long surface stay times will be justified.

There are two basic ways to provide the needed supplemental power to the landing pad. One involves the use of an electric cord extended from a central base power system and the other a self-contained portable power supply. Some baseline requirements must be established to allow comparison of these two types of systems. To that end, it is assumed that the lander will require 2 kW of power for a period of 28 days. For the application described, the possibility of an inaccurate landing some kilometers away from the planned site, along with other versatility needs, will weigh heavily toward the self-contained power supply. If vehicle surface stay times increase, the balance may be shifted towards the cord system. This will occur for alternate ascent stage concepts in which the crew leaves the Moon in the vehicle used by the last crew providing complete ascent stage redundancy. Figures 12 and 13 show drawings of both type of systems.

The cord system consists of a 1-km long cord on a spool that is mounted on a four-wheeled cart. A power conditioning system consisting mainly of a transformer and rectifier is available on the cart to provide a variety of voltages including the standard 28V DC spacecraft electrical power. The overall mass of the system is estimated at 910 kg. Table 4 provides a mass breakdown and dimensional data. When needed, the cord is plugged into the base power system and unreeled to the site needed. Another cord can be connected between the vehicle and the power supply, and the lander will have the needed power. If additional distance is needed, another extension cord can be connected to the first, bypassing the transformer system.

There are several options available for the portable self-contained system. Among them, fuel cells and nuclear isotope generators appear to provide the best possibilities. Batteries will not be examined for this system, since the storage requirement of nearly 1500 kWhr will result in a massive system. Masses as low as the 5 kg per kWhr of zinc-silver batteries would result in a 7.5-t system. In addition, solar cells will not be considered as a primary power supply. Since the system must be operated during

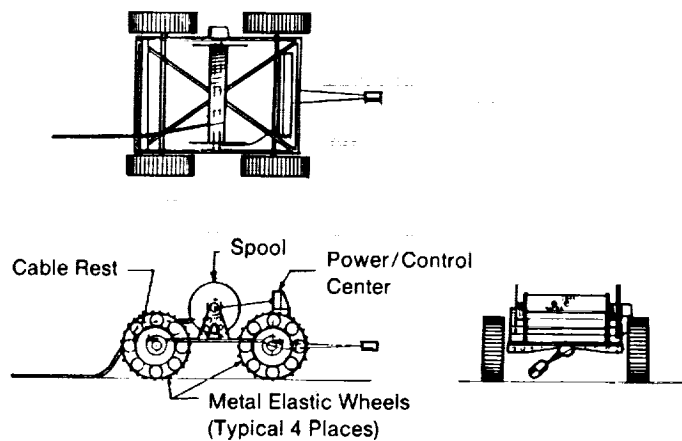

Fig. 12. Electric cord system.

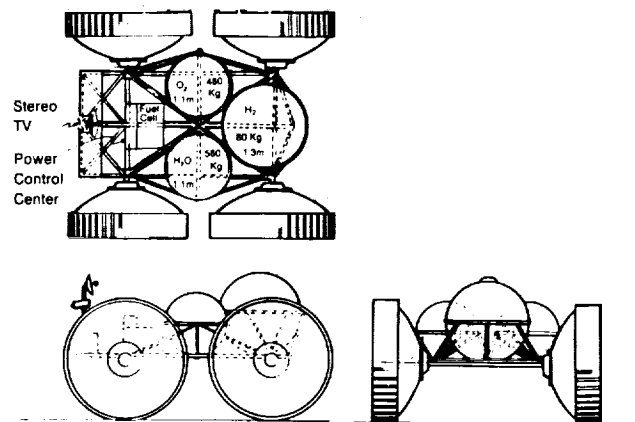

Fig. 13. Fuel cell power cart.

the lunar night, solar cells cannot be used for continuous power. These solar cells can be used as a source supplemental to the primary power generation system. Nuclear systems use technology that is not well known, and they involve some difficult political and safety issues. As a result they will not be considered here. Fuel cell technology is well developed, and application to the space shuttle and previous programs has proven it to be an operational technology. As a result, a fuel cell system is proposed for the self-contained power supply or "power cart."

The power cart consists primarily of cryogenic hydrogen and oxygen tanks, liquid water tanks, and a fuel cell system mounted on a four-wheeled cart. A solar cell can be mounted on the cart to provide extra power during sunlight periods. The estimated mass of the fuel cell power cart is 1290 kg. Table 4 provides a mass breakdown and dimensional data for this system. When a lander needs power, the cart is taken to the landing pad. The power cart is connected to the vehicle in the same way as the electric cord system. The fuel cell is then activated, and the

TABLE 4. Vehicle power supplies.

Electric Cord System (1 km)	
Conductor	490 kg
Insulation	250 kg
Power Conditioner	20 kg
Cart	90 kg
Total	820 kg

Dimensions: 2.0 m long; 1.4 m wide; 1.1 m high.

Fuel Cell Power Cart (2 kW, 28 days)

Tanks	
Hydrogen	190 kg
Oxygen	130 kg
Water	130 kg
Fuel Cell	90 kg
Solar Panel (1 kW)	40 kg
Cart	150 kg
Dry Mass	730 kg
Reactants	560 kg
Total	1290 kg

Dimensions: 4.3 m long; 1.3 m wide; 1.3 m high.

Tanks	
Hydrogen	1.3 m diameter
Oxygen	1.1 m diameter
Water	1.1 m diameter

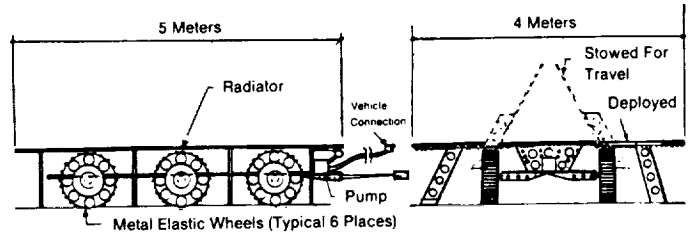

Fig. 14. Supplemental cooling cart.

TABLE 5. Supplemental cooling system.

Radiator	340 kg
Pipes	390 kg
Pump	20 kg
Cart	190 kg
Water Working Fluid	230 kg
TOTAL	1170 kg

vehicle has the appropriate power. After use, the cart can be taken back to a central regeneration station where it is charged for its next use.

Both the cord and cart systems have compelling and complementary advantages. Both systems can be used for many tasks other than simply supplying power to a lander. There will be need for power away from the base for a variety of transportation, construction, and other tasks, as well as for vehicle maintenance. Because of these needs, both types of systems are recommended. In fact, more than one of each may be required depending on how many simultaneous tasks are undertaken.

Supplemental Cooling Cart

For reasons analogous to the need for electrical power, a supplemental cooling system will be needed for piloted vehicles on the landing pads. The vehicles and their systems must be kept cool during the lunar day when reflection and reradiation from the lunar surface will add to the direct sunlight experienced in space. These vehicles will have their own onboard cooling power systems sized only for direct solar heat loads. A supplemental cooling system (SCS) will add radiator surface for the lander cooling system to allow it to handle the additional cooling loads of the lunar day.

The SCS will consist primarily of a radiator sized at a minimum to reject the added cooling load from the lunar surface and at a maximum to reject the entire vehicle cooling load. Since these loads are unavailable at this time, a load of 2 kW is assumed. The radiator can be sized at 2 kW for an average radiator surface operating temperature of 15°C. At this temperature, estimates of heat rejection are about 100 W per sq m for simple radiators (*Lunar Bases Synthesis Study*, 1971). At this rate, the radiator will be 20 sq m or about 4 m x 5 m.

The SCS shown in Fig. 14 has a deployable radiator system in three sections. The system mass is about 1170 kg. Table 5 provides a mass breakdown and some dimensional data. The system is mounted on a cart similar to the one used for the fuel cell power cart described above. This is a simplistic radiator system. Other

more sophisticated radiator designs have been proposed for applications such as this. The design presented here is intended to provide a conservative, rough order of magnitude size and weight. Further detailed design must be performed once better data on the expected heat load are known. Coolant choice must also be considered to ensure proper operation over the entire range of surface conditions.

Micrometeor Protection

It is probable that some vehicles that will remain on the surface for long periods will need to be protected from exposure to micrometeors. One concept for providing this protection is the use of a vehicle cover or blanket that can be draped over the entire vehicle or over selected systems sensitive to the expected micrometeor bombardment. These blankets would serve as bumpers supplemental to those already provided on the vehicle itself. Blankets such as this will be needed for blast protection. The same sort of material can be used. Multilayer mylar sheets or kevlar fabrics may provide appropriate protection.

SITE DEVELOPMENT

The evolution of lunar base landing facilities can be summarized in what will be known as a Site Development Plan. This plan must be meshed with other plans for lunar base development to ensure that appropriate facilities and equipment are available when they are needed. The Site Development Plan will indicate how and when the facility elements defined above will be used at the launch and landing facilities. The needs and evolution are translated into particular schemes. Generally known as "scenarios," these objectives, goals, and schemes are dynamic. Many scenarios for lunar development have been proposed and continue to be proposed. Scenario development and evaluation is a current and continuing process; thus, it is obvious that no one Site Development Plan may be proposed with hopes of it being valid for long. Each lunar base scenario must have its own Site Development Plan.

The primary interest in this planning is to affect the evolution of the lunar base in only modest ways if at all possible. This approach allows delivery schedules and crew activities to relate to the objectives of the base itself and not to a sideline effort such as development of landing facilities. The development of lunar landing facilities for a Phase II lunar base follows one general path. There are three stages along this path: early landing facilities, temporary landing facilities, and permanent landing facilities. Depending on the nature of the individual scenario, the length of any of these stages may vary. However, the activities within each stage are the same no matter which scenario is chosen. Figure 15 illustrates layouts of landing pads with respect to the base for the three development stages.

Base Objective Dependence

The objective of the base will affect primarily the transition from temporary to permanent facilities, although the early stage can be affected indirectly. The main dependence is derived from cargo operations and the need for cargo loading and alignment operations. Support for a scientific base can generally be characterized by the need for instrument and construction equipment, logistic resupply deliveries, and sample returns. All other things aside, if the sample return requirements are low, permanent, reusable landing pads may never be needed. A resource-oriented base will have an obvious export. While the specific operation is not of importance here, when the export

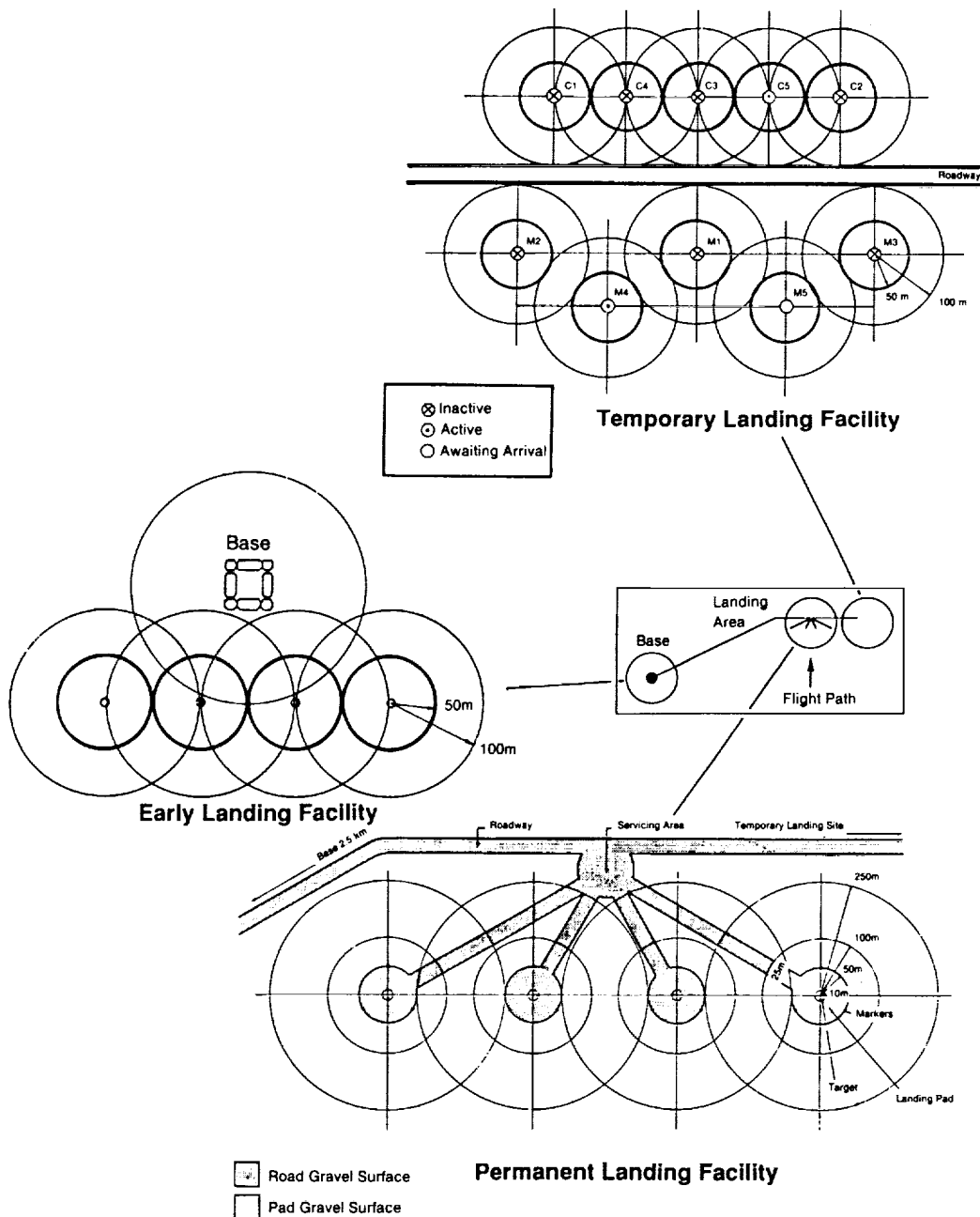

Fig. 15. Landing pad layouts.

activity begins in earnest, permanent pads will be needed and the transition from temporary to permanent stages will occur. A habitation base alone will, in general, not require a permanent landing facility. Since no product is shipped from the surface, no major cargo loading takes place.

Base Growth Dependence

The rate of growth of habitation facilities and the growth of surface stay times affect landing facilities in different ways and at different periods. Habitation growth relates directly to the early temporary stage transition. If habitation is important, the base will be rapidly developed to allow dwelling in the base. At this point, as long as some sort of vehicular surface transportation is available, the pads may be moved away to the remote sites and the temporary stage can begin. If the base is developed slowly, the early stage will be protracted, and the vicinity of the base may actually become littered with spent stages and used landing pads.

Stay-time growth will affect the transition from temporary or early stages to permanent stages. When surface stay times increase to the extent that reusable pad setup and maintenance becomes a fairly small percentage of available time, the permanent stage can be justified. Although not necessarily, this is usually associated with permanently occupied operations and would be very near the end of Phase II operations.

Flight Vehicle Dependence

The specific design of the lunar lander will affect pad location, equipment protection, and servicing requirements. These effects are related to the size and thus the thrust levels and the expendable vs. reusable nature of the vehicle.

If growth of flight vehicles increases or decreases the size of the engines, some change to site development may be indicated. Generally, ejecta from larger engines will be larger and travel farther and faster than for smaller engines, and facilities will need to be spread out.

The use of a reusable lander will affect the transition to permanent stages and the nature of facilities located at the pad. When a reusable vehicle begins to need servicing on the lunar surface, facilities for this servicing will be required. If the nature of the servicing is such that simple EVA is unacceptable, whether because of crew time or servicing complexity, the transition to the permanent stage must be made. This will occur regardless of the current stage. If the early stage is the current one, the temporary stage may be skipped altogether. If the facilities needed to handle the permanent operations are not available, they must be provided.

CONCLUSIONS

Launch and landing facilities and their growth rate depend on the base development scenario. The major emphasis of the base, the rate of emplacement of facilities, and the design of the flight vehicle will all play major roles in the requirements for facilities. Resource utilization bases will require more and different landing facilities than will science or habitation bases. The more rapidly some base capabilities are achieved, the more rapidly landing facility capabilities are required. Vehicles that require extensive

surface-based servicing will require leveled permanent landing areas. These permanent reusable landing pads are not needed or desired before major resource export or vehicle servicing activities take place. For some lunar base scenarios, permanent landing pads may never be needed.

With few exceptions, lunar landing facilities and equipment are present on the lunar surface for other reasons before they are needed for landing operations. Landing equipment and facilities will probably not be major drivers of delivery schedules and mission plans.

Based on the calculations done during this study, the effects of engine blast are significant. While they are not critical or life threatening, they must be considered. Equipment within 50 m of a landing may experience severe damage due to the impact of fairly large grains of lunar soil. Equipment over 400 m away will require only minimal protection. At 1 km to 2 km blast effects are very small.

Landing pads can be designed without general regard to the specific landing site because overall surface conditions are fairly uniform across the entire lunar surface. Landing pads, whether prepared or not, should be about 100 m across. The area just outside this circle to 200 m across should not include any major obstructions such as boulders or expended landers. Lunar-derived gravel may be used to stabilize prepared landing pads.

RECOMMENDATIONS

More work is needed concerning blast effects, vehicle servicing on the surface, site planning and development, and safety and rescue operations. More design definition is needed for surface stabilization methods, cryogen storage and transfer facilities, servicing and maintenance equipment, and other items.

The launch and landing facilities of a permanently occupied base need to be defined. This study was limited to the initial lunar base, and the facilities needed for extensive permanently occupied or Phase III bases have only been reviewed in a cursory fashion.

REFERENCES

- Cour-Palais B. G., Flaherty R. E., High R. W., Desler D. J., McKay D. S., and Zook H. A. (1971) Results of the Surveyor III sample impact examination conducted at the Manned Spacecraft Center. *Proc. Lunar Sci. Conf. 2nd*, pp. 2767-2780.
- Minutes of Apollo Site Selection Board, February 1972. On file at Lunar and Planetary Institute Library, Houston.
- Mitchell J. K., Carrier W. D., Costes N. C., Houston W. N., Scott R. F., and Hovland H. J. (1973) Soil mechanics. In *NASA SP-330*, pp. 8-1 to 8-22.
- Moore H. J. and Tyler G. L. (1973) Comparison between photogrammetric and bistatic-radar-slope-frequency distributions. In *NASA SP-330*, pp. 33-17 to 33-26.
- North American Rockwell, Space Division (1971) *Lunar Base Synthesis Study: Shelter Design*. Final Report for NASA Contract NAS8-26145, pp. 1-4-4 and 3-1-8.
- Wilbeck J. S., Anderson C. E., Wenzel A. B., Estine P. S., and Lindholm U. S. (1985) *A Short Course on Penetration Mechanics*, pp. 15-27. Southwest Research Institute, San Antonio.