

PRECEDING PAGE BLANK NOT FILMED

PREFABRICATED FOLDABLE LUNAR BASE MODULAR SYSTEMS FOR HABITATS, OFFICES, AND LABORATORIES

N 9 3 - 1 7 4 4 4

Yousef Hijazi

Architectural Horizon
Box 2
Makkah, Saudi Arabia

MOBILE ARCHITECTURE

In spite of the advanced building technologies available today, concepts for mobile architecture are still limited to certain styles and applications. Prefabrication of buildings as complete units to be produced in a factory assembly line is only possible for certain types of stationary and mobile structures. However, the concept of a multistory, prefabricated, foldable, modular, structural unit has paved the way for almost unlimited sizes of building complexes to be prefabricated, preassembled, and shipped to a site for fast erection.

As a new approach, the prefabricated, modular, multistory, structural system was introduced for the first time for the purpose of pilgrim accommodation in the holy city of Makkah, Saudi Arabia. Characterized by its own unique patented construction and adaptable to special purposes, this concept is thought of as a new trend of mobile architecture. Several applications, such as residential apartments, offices, schools, and hospital systems, were proposed in multistory, foldable structures with the proper modifications to fit each purpose.

The overall size of each of these complexes depends upon required functions. Transportation of the individual prefabricated modules can be via trucks, trailers, or they can even be self-driven. It is also possible to launch these foldable units in special space vehicles, opening the door for a new era of human settlements on other planets. The units would be equipped with adequate facilities for initial settlements.

LUNAR SETTLEMENT

Prior to the establishment of lunar scientific and industrial projects, an innovative architectural approach for a self-contained lunar base is very much needed. The aim is to provide essential protection from solar flare radiation and to house preliminary facilities and personnel for the very initial stage when manual construction operations may be difficult.

In view of the various problems connected with the initial lunar settlement, the basic characteristics of such an approach were analyzed as follows:

1. Independence from the expensive transportation of large and heavy building materials, site preparation machinery, and construction equipment and mechanisms.
2. Providing self-opening and site self-adjustment means to avoid using heavy and complex lifting mechanisms and site preparation machinery.

3. Self-erection of the entire base to minimize manual construction operations that require sizeable labor forces.

4. Utilization of local resources for galactic radiation flux protection, rather than terrestrial means, which must be imported, or the use of elaborate operations for tunnel digging or regolith massshielding.

5. A self-sufficient and self-contained lunar base of initial settlement, which is the precursor for additional research and development leading to a lunar city.

6. Providing conventional, habitable, and usable architectural spaces suitable to the 1/6-g environment.

7. Providing a modular, flexible, and expandable interconnected network for different future activities of a lunar base.

Evolving from the same philosophical approach of space settlements (i.e., space stations), it is believed that a prefabricated, self-contained system, providing all necessary life-support, is most appropriate for the initial stage of lunar colonization and manned settlement.

LUNAR BASE CONCEPTS

The first habitat and work station on the lunar surface undoubtedly has to be prefabricated, self-erecting, and self-contained. The building structure should be folded and compacted to the minimum size and made of materials of minimum weight. It must also be designed to provide maximum possible habitable and usable space on the Moon. For this purpose the concept of multistory, foldable structures was further developed.

The idea is to contain foldable structural units in a cylinder or in a capsule adapted for launching. Upon landing on the lunar surface, the cylinder of the first proposal in this paper will open in two hinge-connected halves (Fig. 1.1), while the capsule of the second proposal will expand horizontally and vertically in all directions (Figs. 2.2, 2.3, and 2.4). In both proposals, the foldable structural units will self-erect providing a multistory building with several room enclosures. The solar radiation protection is maintained through two regolith-filled pneumatic structures as in the first proposal (Fig. 1.4), or two regolith-filled expandable capsule shells as in the second one, which provide the shielding while being supported by the erected internal skeletal structure.

LUNAR BASE MODULE—FIRST PROPOSAL

The typical lunar base module proposed here is a cylinder 11 m in diameter and 40 m in length connected to a lunar shuttle vehicle.

The cylinder will longitudinally open to form two hinge-connected halves (Fig. 1.1). The self-opening mechanism will initially depend on lunar gravity for the two halves to open, and then the book-like opening will be completed by means of a built-in tension cable system. Horizontal stability is maintained by the same cable mechanism, assisted by a hydraulic footing system.

Each half of the cylindrical module contains four foldable structural units. Two units will form a pair that lean against each other when unfolded (Fig. 1.2). The typical structural unit is 9 m long and 3 m wide and consists of one rigid and four collapsible floors (Fig. 1.5). The typical floor-to-floor height is 2.5 m. The lower rigid floor of each structure provides two room enclosures,

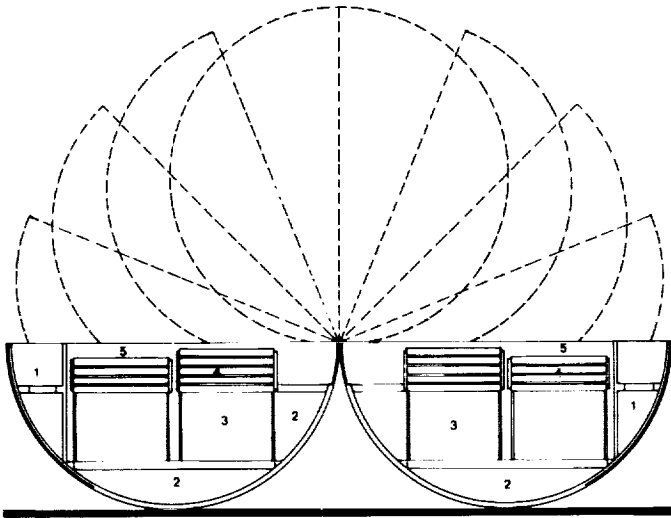

Fig. 1.1. Hinge-connected cylinder halves. Cross section showing folded structures. (Legend: 1. Ground regolith pumped between two layers of pneumatic structures and flowing to shield module sides. 2. Infrastructure and utility space. 3. Rigid floor and fixed installations. 4. Foldable structural units and room enclosures. 5. Pneumatic structures or capsule shells.)

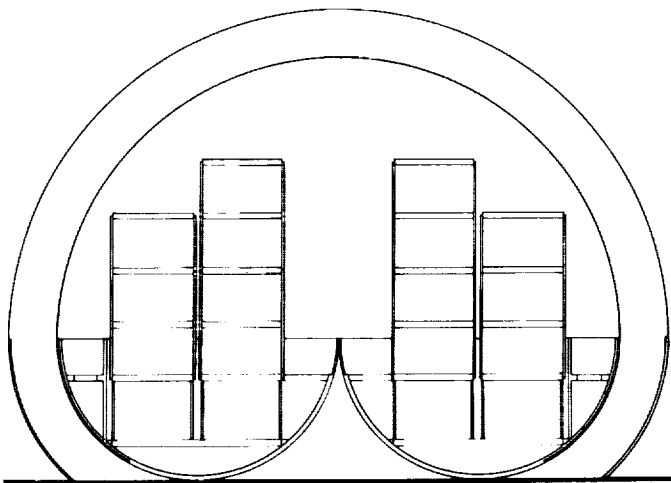

Fig. 1.2. Cylinder cross section. View during foldable structure self-erection.

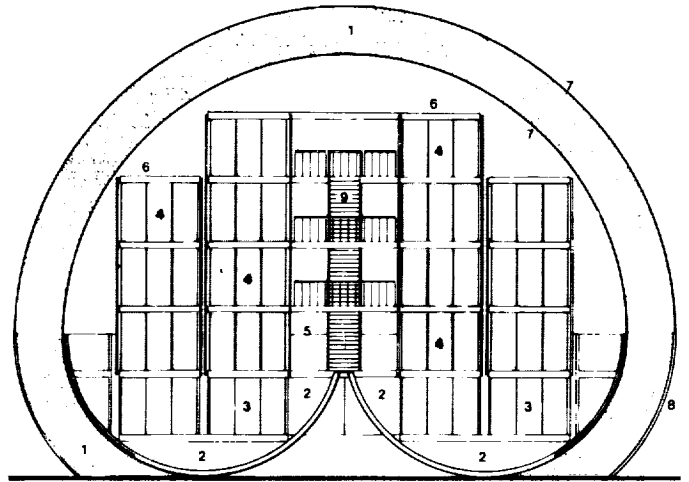

Fig. 1.3. Lunar base module interior elevation: (Legend: 1. Ground regolith pumped between two layers of pneumatic structures and flowing to shield module sides. 2. Infrastructure and utility space. 3. Rigid floor and fixed installations. 4. Foldable structural units and room enclosures. 5. Central hall. 6. Usable space. 7. Pneumatic structures or capsule shells. 8. Side shields to allow regolith to flow down. 9. Staircases to be assembled.)

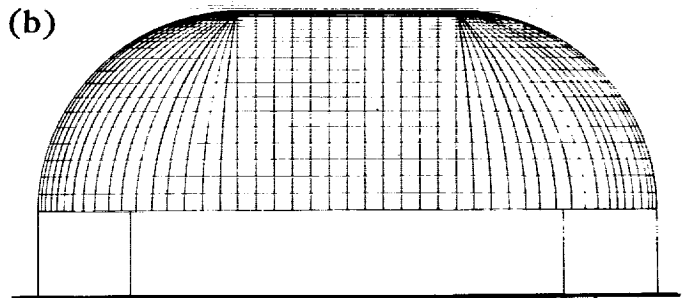
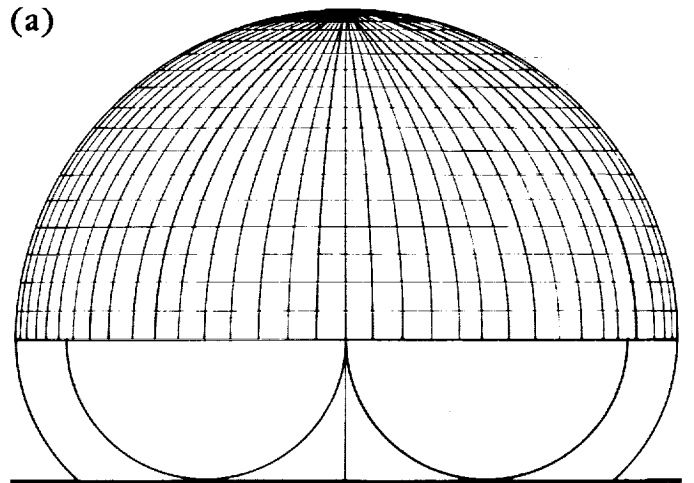

Fig. 1.4. View of cylinder after pneumatic structure inflation: (a) side elevation; (b) long side elevation.

while two additional rooms will be provided in each of the upper collapsible floors. Lightweight wall panels will unfold from the ceilings to form enclosed rooms (Fig. 1.3). Following the self-erection of the structural units (Figs. 1.2 and 1.5c), prefabricated stairwell components are assembled inside the base for vertical access (Fig. 1.6). To facilitate the unfolding process of the structural units without any additional external lifting facilities, the self-erection mechanism is built in.

The size of the lunar base module can be varied depending upon the launching capacity. Similarly, the size of the foldable structures can be varied to accommodate the internal carrying capacity of the lunar base module.

FIRST PROPOSAL COLLAPSIBLE STRUCTURE DESIGN

The aluminum structural units consist of several collapsible floor slabs 3.2 m wide, 6.5 m to 12.5 m long, and 15 cm thick. The preferred arrangement would have four collapsible floors plus a base platform.

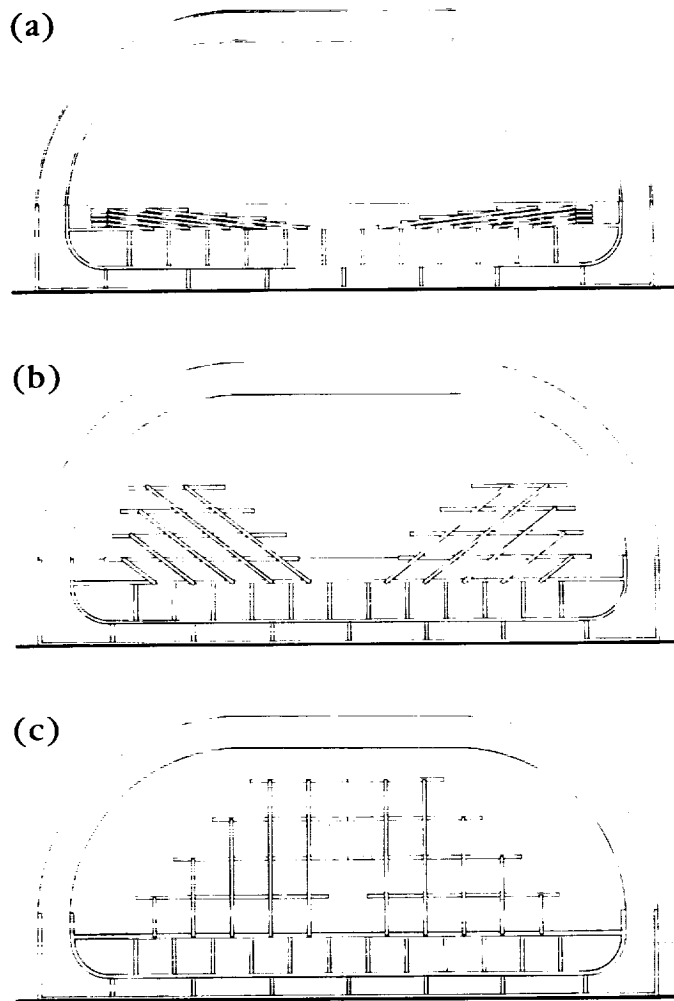

Fig. 1.5. Cylinder longitudinal section: (a) view before foldable structure self-erection; (b) view during foldable structure self-erection; (c) view after foldable structure self-erection.

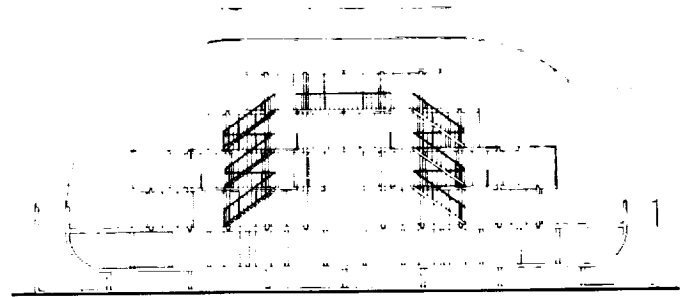

Fig. 1.6. Lunar base longitudinal section.

The floor slab consists of two main parallel longitudinal beams of 6.5 m to 12.5 m in length and 15 cm in height connected by secondary beams 3 m in length. The decking of these slabs could be achieved through suitable lightweight, rigid material, such as fiberglass, with proper final finishing.

Adjacent floor slabs are connected to each other with supportive columns connected to the longitudinal beams by pivotal hinged joints. The hinge connection allows for scissor-like rotations (Fig. 1.5b). Whenever the unit is folded inside the cylinder halves, the aluminum slabs stack neatly above each other in a horizontal position (Fig. 1.5a).

In the unfolded position, a supportive column is connected to the floor slab every 2.5 m. In the same way, every column is connected with a main longitudinal floor beam every 2.5 m in height. This scissor-like grid of vertical columns intersecting with horizontal floor slabs (as seen from the side elevation of the unit; Fig. 1.5c) allows for the rotation of columns and maintains the horizontal stability of the floor slabs, thus achieving the system's foldable and collapsible nature.

A self-winch mechanism is attached to the top floor slabs of each pair of foldable units. A cable connects the pair of winches to form one lifting mechanism. When the cable is wound around the winch, the folded structures will automatically be raised to their upright positions. Other self-uprighting mechanisms could also supply the required forces to raise the structures.

The rigid floor upon which each foldable unit is erected is integrated structurally with the cylinder half where it is contained to form a base platform (Figs. 1.1 and 1.5a). This base platform will permanently accommodate laboratories, work stations, fixed utility machinery, and infrastructures in eight 3×5 -m rooms. For the purpose of seating astronauts and crew members during the trip, some of these rooms will be used as seating compartments. Some spaces between the rigid floor and the cylinder half will temporarily be used as storage areas for the furniture and equipment of the upper collapsible floors. The rigid floor is reached through a permanent staircase leading up to the main central space of the lunar base (Figs. 1.3 and 1.6).

Corridors formed between the rooms of the base platform are 2.5 m wide and 2.3 m high. Through the use of square telescope sliding corridors, adjacent lunar base modules can be interconnected. This width and height will allow for a future motorized circulation network when many more modules are interconnected within the future lunar city layout.

An erection sequence for a module, culminating in the installation of regolith shielding, is illustrated in Fig. 1.7. Models on a simulated lunar surface are shown in Fig. 1.8.

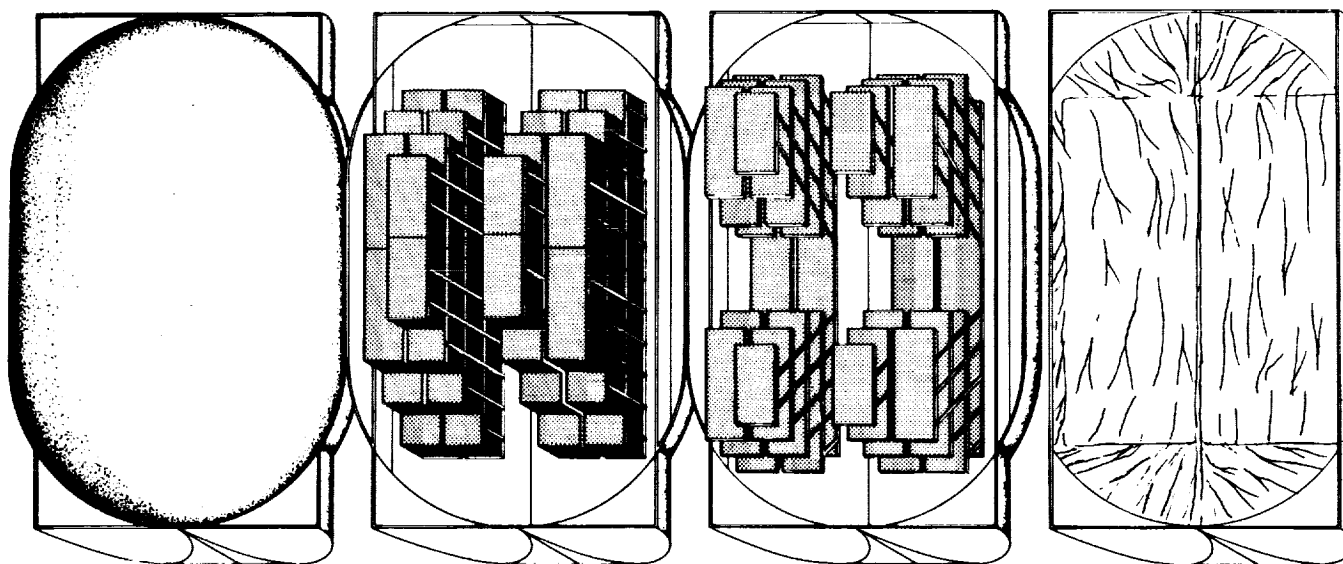

Fig. 1.7. Prefabricated lunar base modular systems (habitats, offices, and laboratories).

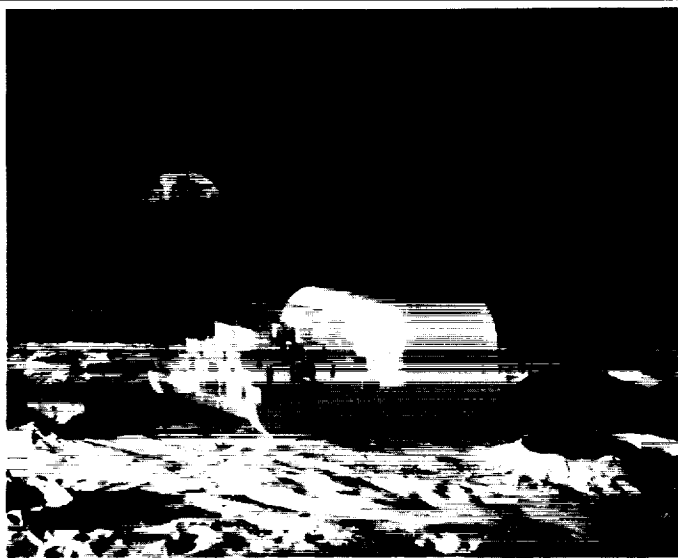

Fig. 1.8. Models of modules on a simulated lunar surface.

LUNAR BASE MODULE—SECOND PROPOSAL

The typical lunar base module in this proposal is a capsule 12 m in diameter (Fig. 2.1) and 30 m in length with two half-sphere ends. The exterior cylindrical and spherical envelopes consist of two expandable shells. The idea is to have this capsule expanded and amplified to provide larger habitable and usable space on the Moon. The outer shell will expand to make a 42-m-long capsule with a diameter of 24 m (Figs. 2.3 and 2.4). The inner shell will provide an internal sealed capsule 18 m in diameter and 36 m in length. The 2-m to 3-m cavity between the two expanded shells will be filled with either ground regolith or bags that contain the lunar soil.

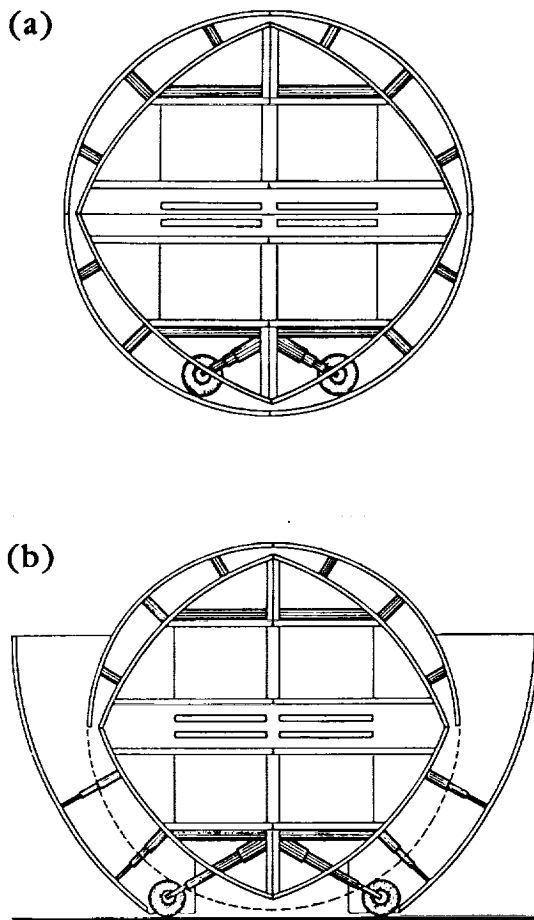

Fig. 2.1. Section of folded capsule (a) before landing; (b) after landing.

The original capsule is longitudinally split into four quarters and recombined through an internal skeletal structure and a set of horizontal and vertical hydraulic pistons. In its folded position, it contains two rigid floors with three folded collapsible floors in between (Fig. 2.1).

Prior to landing, the lower parts of the external capsule shell will slide and open to allow for proper landing with the assistance of the lunar shuttle vehicle jets (Fig. 2.2a). Immediately after

landing on the lunar surface, the capsule will expand in two opposite horizontal directions (Fig. 2.2b). The two halves, 6 m apart, will maintain their structural connection and stability. The two half-sphere ends will then expand horizontally in the other directions (Fig. 2.2c).

The self-erection of the folded structure will make it rise and complete the vertical expansion of the capsule, providing a multi-story building structure (Figs. 2.3 and 2.4).

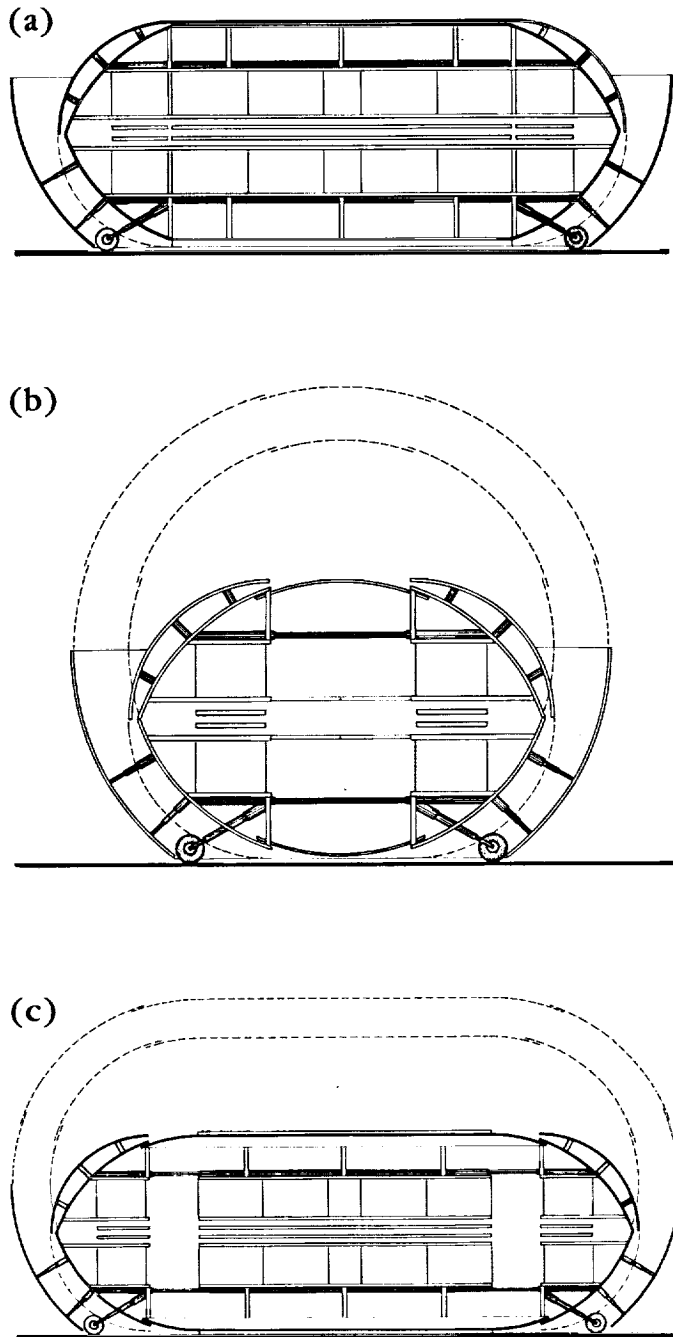

Fig. 2.2. (a) Longitudinal section before horizontal expansion. (b) Section showing capsule during horizontal expansion. (c) Longitudinal section after horizontal expansion.

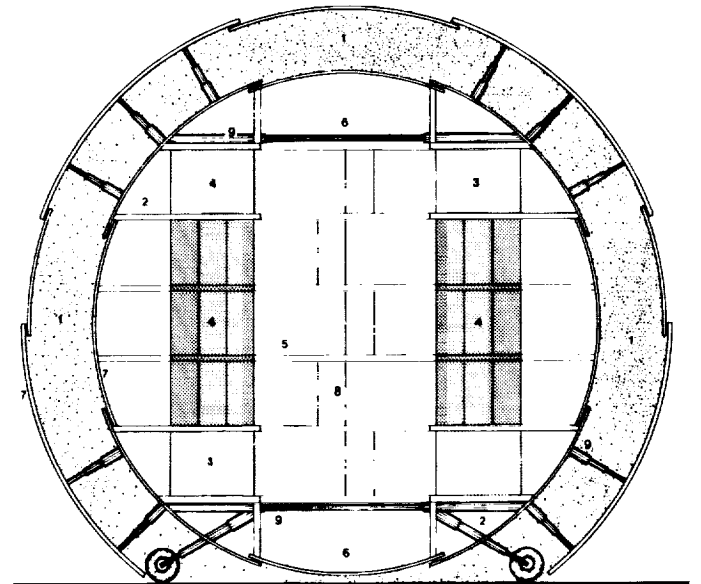

Fig. 2.3. Cross section. (Legend: 1. Ground regolith pumped between two layers of pneumatic structures and flowing to shield module sides. 2. Infrastructure and utility space. 3. Rigid floor and fixed installations. 4. Foldable structural units and room enclosures. 5. Central hall. 6. Usable space. 7. Pneumatic structures or capsule shells. 8. Staircases to be assembled. 9. Hydraulic piston.)

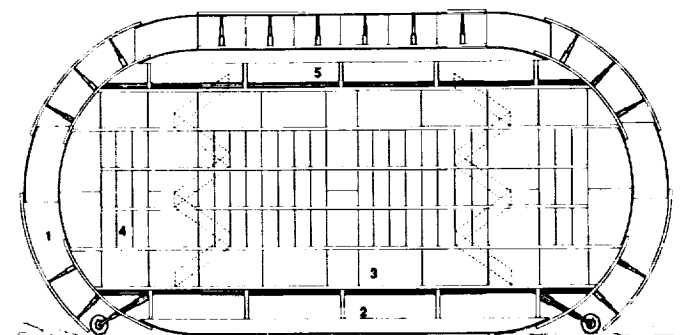

Fig. 2.4. Longitudinal section showing foldable structures after self-erection (vertical expansion). (Legend: 1. Ground regolith pumped between two layers of pneumatic structures and flowing to shield module sides. 2. Infrastructure and utility space. 3. Rigid floor and fixed installations. 4. Foldable structural units and room enclosures. 5. Usable space.)

SECOND PROPOSAL COLLAPSIBLE STRUCTURE DESIGN

The aluminum structural units of this proposal are integrated with the internal shell of the capsule. They consist of two rigid floors 6 m to 10 m wide (Fig. 2.1a) and 24 m to 28 m long (Fig. 2.2b) in the folded position. After the expansion of the system, these floors will become 13 m to 14 m wide (Fig. 2.3) and 31 m to 34 m long (Fig. 2.4). There are three collapsible floors folded between the two upper and lower rigid floors (Figs. 2.1 and 2.2b). The vertical unfolding of the structure will generate the space of these three collapsible floors of 16 m to 17 m in width (Fig. 2.3) and 30 m to 34 m in length (Fig. 2.4).

The rigid floor slabs consist of 15-cm-thick main and secondary beams. The collapsible floor slabs consist of two main parallel longitudinal beams 24 m in length and 15 cm in height connected by secondary beams 3 m in length. The decking of these rigid and collapsible slabs could be achieved through suitable lightweight, rigid materials such as fiberglass, with proper final finishing.

Rigid floor slabs are connected by rigid, supportive columns connected to the longitudinal beams. In the case of the collapsible floors, the supportive columns are connected to the beams by pivotal hinged joints. Each column will bend in two halves with the help of a middle pivotal hinged joint. This bending ability of the column will give the structure the chance to collapse and fold. The self-erection mechanism of the system is achieved through a set of hydraulic pistons that fulfill the vertical expansion providing the total of five typical floors 2.5 m in height.

COLLAPSIBLE FLOOR ROOM ENCLOSURES

Single-room enclosures are created in each of the collapsible floors of the foldable structures in both proposals. This could be achieved through the use of wall panels stored in compartments in the floor/ceiling slabs. One example is to have the panels unfold from a ceiling slab to be fixed to a floor slab providing a typical 3 × 4-m or 3 × 5-m room. These rooms could be easily elongated, combined, or even redesigned to fit required functions. They will be furnished as habitats, offices, work stations, or medical facilities.

The wall panels are prefabricated out of lightweight solid or transparent synthetic materials, as desired. Foldable furniture could also be built in for greater packing density and added compatibility of the entire structure. The floor will be finished with suitable material for each purpose. Ceilings will accommodate the lighting system, air conditioning, and any other utility infrastructure. A total of 60 single-room enclosures could be available in the first proposal, occupying 860 sq m. There are an additional 255 sq m of usable terrace space, which is the space between the upper floor roof slab and the curved pneumatic canopy. Adding the corridors and the open space results in a total usable area of 1520 sq m. In the second proposal, a total of twenty-four 3 × 3-m and 3 × 4-m single-room enclosures in the rigid floors is possible and 36 single-room enclosures of the same area in the collapsible floors. There are an additional 1880 sq m of usable open space in different floors. The total area provided in this proposal is 2640 sq m.

STAIRS

Stairs are necessary for personnel movement between floors. Following the self-erection of the foldable structures in both proposals, staircases will be positioned between the two inner

pairs of the structural units. Due to the lightness and design simplicity of the stair components, manual assembly could be performed by the crew members inside the lunar base modules.

GALACTIC RADIATION FLUX SELF-PROTECTION

The galactic radiation flux self-protection concept requires ground regolith to be pumped in and to fill a space created between the two outer layers of the pneumatic structure in the cylinder proposal or the cavity between the internal and external shells in the capsule proposal. This concept utilizes the lunar soil as a shield; thus, expensive and heavy shielding does not have to be transported from Earth. While being affixed to the exterior edges of the longitudinal halves of the cylinder, the two layers of the pneumatic structure are inflated prior to the self-erection of the structural units. Ground regolith is then pumped into the cavity between the two layers until it is completely filled. The load created from the regolith shielding canopy is transferred by the erected skeletal structure down through the vertical supports to the lunar surface. The cylinder halves are designed to accept a flow of ground regolith to fill their sides insuring complete shielding. Ground regolith could be provided by a special vehicle designed to drive on the lunar surface and collect, grind, and pump regolith through special pipes in order to fill the cavity in the inflated pneumatic structures. The outer layer of the pneumatic structure could be designed so that it is expandable in order to increase the size and thickness of the cavity if additional shielding is required. Another way to achieve the same goal is to collect regolith in bags and stack them in the cavity between the pneumatic structures. The same approach could be followed in the second proposal, utilizing the cavity between the two capsule shells for galactic radiation flux self-protection.

MODULE VARIATIONS

Additional future modules of both proposals could be entirely devoted to specialized functions such as hospitals, medical facilities, specialized laboratories, and prefabricated plants and factories. By eliminating some floor slabs and keeping only the skeletal structure, agricultural fields could be created in larger span enclosures. In the same way, aquariums and zoological gardens could be established.

CONTINUATION OF RESEARCH AND DEVELOPMENT

The initial lunar settlement of prefabricated foldable modules as proposed in this paper is thought of as providing a pioneer settlement that will pave the way for later phases of lunar-based construction capabilities. The proposed designs will accelerate the planning process for early manned presence on the Moon; therefore, it is worth further investigation to test various aspects and concepts outlined above. A full-scale prototype could be built for testing the self-opening, the site self-adjustment, and the self-erection mechanisms with respect to the 1/6-g lunar environment. In addition, various materials can be experimented with to provide a structure that uses lightweight materials to provide sufficient structural strength.