

# VERTICAL REGOLITH SHIELD WALL CONSTRUCTION FOR LUNAR BASE APPLICATIONS

N 9 3 - 1 7 4 4 6

**Jan Kaplicky and David Nixon**

*Future Systems Consultants  
1103 South Hudson Avenue  
Los Angeles CA 90019*

**Jane Wernick**

*Ove Arup & Partners California  
10780 Santa Monica Boulevard, Suite 300  
Los Angeles CA 90025*

*Lunar bases located on the lunar surface will require permanent protection from radiation and launch ejecta. This paper outlines a method of providing physical protection using lunar regolith that is constructed in situ as a modular vertical wall using specially devised methods of containment and construction. Deployable compartments, reinforced with corner struts, are elevated and filled by a moving gantry. The compartments interlock to form a stable wall. Different wall heights, thicknesses, and plan configurations are achieved by varying the geometry of the individual compartments, which are made from woven carbon fibers. Conventional terrestrial structural engineering techniques can be modified and used to establish the structural integrity and performance of the wall assembly.*

## PURPOSE

An established lunar base located on the lunar surface will require permanent protection from ionizing radiation sources and from engine blast debris or ejecta. Radiation, which includes galactic cosmic radiation and solar cosmic radiation (NASA, 1989), is particularly lethal in the form of solar flare radiation produced during periods of intense cyclic activity. The generation of debris and ejecta trajectories caused by vehicle engine blast during launch and landing operations is significant and accommodation and facilities must be shielded accordingly (Phillips et al., 1988). Though debris and ejecta are to some extent directional, radiation is isotropic, indicating that full enclosure of lunar base accommodation and facilities will be necessary for a permanently manned lunar base. The most economical and effective method will be based on mass-shielding using local lunar regolith as the shielding material.

This paper describes continuing studies of autonomous superstructure systems designed to provide the required complete proximity shielding of accommodation facilities located on the surface. A method of providing horizontal shielding above a lunar base complex has previously been described (Kaplicky and Nixon, 1985), and this paper outlines an approach toward the configuration of shielding as a vertical wall. It is anticipated that both systems can be integrated and reconfigured as a complete enclosure, given the availability of programmatic data on the architecture of the lunar base.

## CONCEPT

Free lunar regolith can be aggregated and constructed *in situ* as a modular vertical wall to surround the lunar base, based on knowledge of the availability of loosely compacted regolith in the vicinity of the lunar surface (Taylor, 1982). Loose regolith is

deposited into individually deployed columns of compartments that are interconnected and reinforced by lightweight vertical struts. The wall is constructed in a progressive linear sequence from the ground up using a construction method that employs an independent mobile gantry using interlocking struts as reinforcement elements. The wall geometry is tailored to the required shape and size for protection (nominally 2 m thick by 7 m high for the purposes of preliminary studies). Key objectives for the concept include (1) maximum simplification and standardization of required fabricated structural elements, (2) maximum control and verification of construction integrity during assembly tasks and sequence, (3) minimum volume and weight of structural elements/components to be transported from Earth, and (4) minimum crew extravehicular activity (EVA) task complexity, physical effort, and construction time on the lunar surface.

## ASSEMBLY

Compartment stacks are transported to the lunar surface in a compact and stowed condition in which the stacks are sandwiched between lightweight pallets. A possible construction for the pallets is a 2-cm-thick alloy waffle panel. Each pallet subsequently acts to help spread the load of the regolith evenly over the prepared regolith ground surface.

In Fig. 1, the stowed stack pallets are retrieved after landing and transported to the construction location using lunar surface vehicles. Field assembly of the shield wall uses a mobile gantry. In Fig. 2, a deployable and independently mobile gantry frame is assembled. Gantry frame design and construction is based on technology derived from the space station beam structure development and already successfully tested in orbit (STS 61B).

In Fig. 3, shield wall stacks are elevated in a bay-by-bay sequence. The folded stack pallets are first placed in the required positions at ground level. The operator moves the gantry over

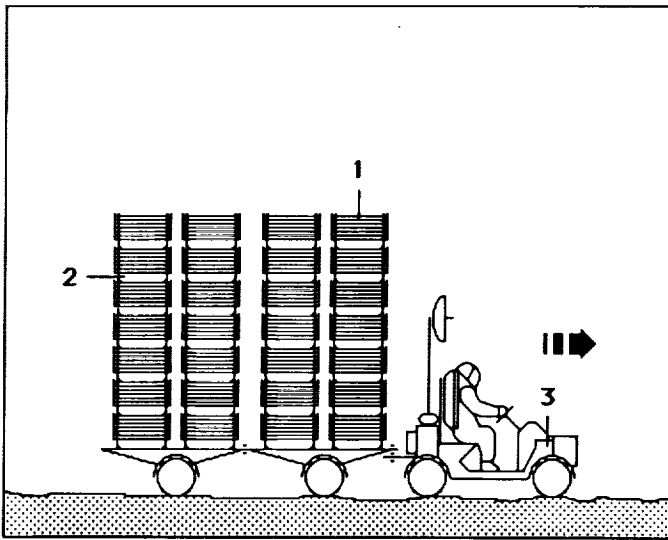

Fig. 1. Retrieval of (1) stowed wall stacks and (2) pallets after landing and transportation to the construction location using (3) lunar surface vehicles.

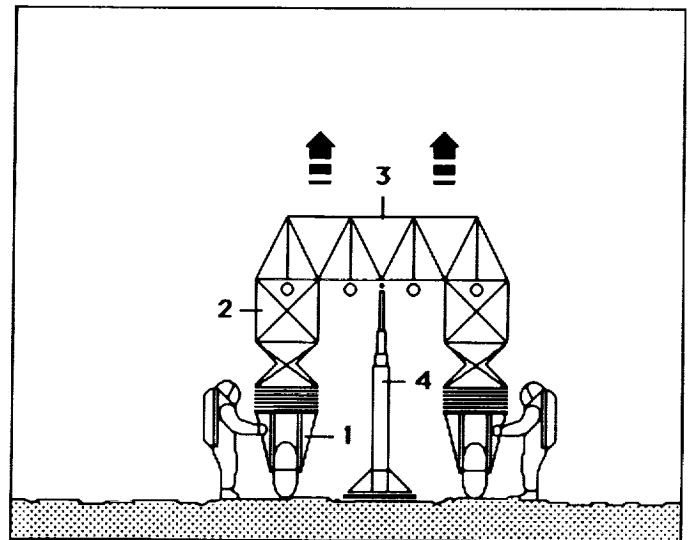

Fig. 2. A deployable and independently mobile gantry frame is assembled: (1) gantry undercarriage, (2) extending framework, (3) crossbar, and (4) lifting mechanism.

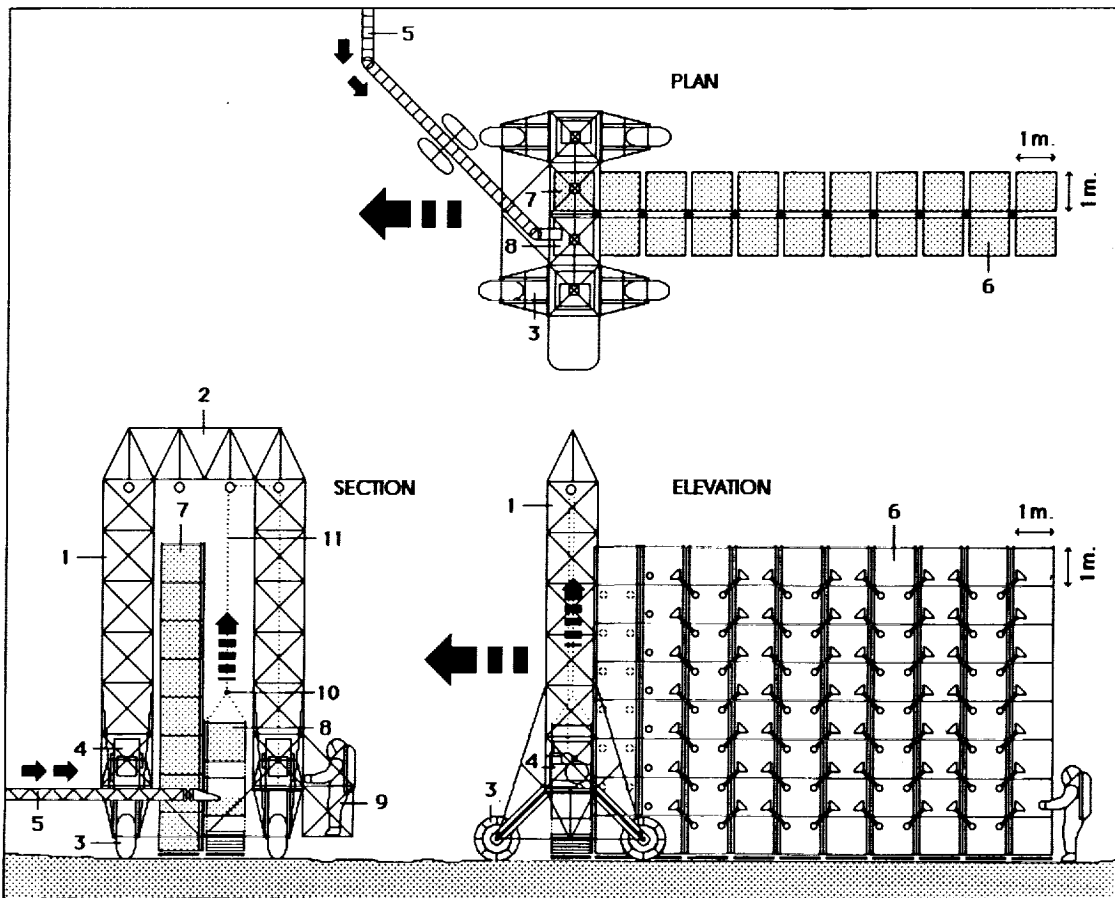

Fig. 3. Shield-wall stacks are elevated in a bay-by-bay sequence: (1) gantry towers, (2) gantry crossbar, (3) gantry undercarriage, (4) gantry drive mechanism, (5) mobile regolith conveyor, (6) completed wall section, (7) completed compartment stack, (8) stack deployment in progress, (9) assembly EVA operator, (10) hook attachment, and (11) hoisting cable.

each stack in turn and attaches a lifting cable and hook to loops attached to the top compartment of each stack. An electric motor at the gantry base winds in the cable to raise the folded compartments vertically. The act of raising the compartments causes them to unfold from the pallet in a controlled deployment by means of integral cables, as shown in Fig. 4. As each compartment unfolds, it is filled with regolith from an independent mobile con-

veyor and closed and secured with an integral flap. The vertical struts are interlocked with matching struts in the adjacent stack, which is already in place. The compartment is then hoisted up. As each filled compartment is hoisted, vertical struts attached to the corners interlock with similar struts attached to the preceding compartment suspended above. This procedure is repeated until all compartments in a single stack are filled, locked together, and suspended from the gantry.

The entire stack is then lowered to the surface where the filled compartments settle into compression. The hook and lifting cable are released from the completed stack and the gantry moves on to the next stack. Regolith loads transfer vertically downward from compartment to compartment and onto the pallet at ground level where they are distributed onto the lunar surface. The overall form of each stack will experience controlled deformation and settlement but will remain contained and stabilized by the interlocking reinforcement struts. Finally, compartment faces are strapped together to provide longitudinal stability using spring-activated microfastener (hook-and-eye) pads.

Once complete, the shield-wall system is essentially inert and will require no maintenance. Periodic inspections will be required to check for damage due to meteor or other debris impact. A method of field repair of damaged compartments will be required to rectify such damage.

## STRUCTURE

The aim is to design a wall that is stable during and after construction and that can resist nominal horizontal loads such as the accidental impact of a crewmember on EVA. It is assumed, for example, that a substantial meteor hit will involve corresponding repair or rebuilding of the wall.

It is assumed that the loose regolith is of the order of 20 cm thick. This will first be cleared from the area where the wall is to stand so that it will be founded on the more dense rock below. If the surface of the rock is not level, it will be built up with a thin layer of regolith to provide a flat base. It is proposed that the structural elements are designed in accordance with the Uniform Building Code (*International Conference of Building Officials*, 1985) as far as allowable stresses, factors of safety, and resistance against buckling are concerned.

Preliminary studies are exploring the feasibility of using carbon fiber cloth bags that are stiffened with alloy struts to form cubic compartments for the regolith, as shown in Fig. 5. The compartments are assembled into vertical stacks that form the wall. Mechanical connection between the compartments is provided at the corners where the struts, which run vertically along two corners of one compartment, interlock with similar struts above. Battens are also used to stiffen the compartments. Four integral battens are incorporated along the edges of the top face of each compartment to keep the cubic geometry in shape while it is filled with regolith. Battens are also incorporated down compartment corners. Lightweight pallets keep the bottom of the compartment stacks flat. Flaps at the top face of each compartment are folded down once filling with regolith is complete and are held in place with microfastener pads. The compartment stacks behave primarily in compression. Some shear stiffness is provided by the connections between the struts and also by the in-plane shear stiffness of the fabric, which can be improved by adopting a triaxial fabric weave and by introducing a regular pattern of microfastener pads on the wall outer elevations to "stitch" the compartment stacks together after deployment. These

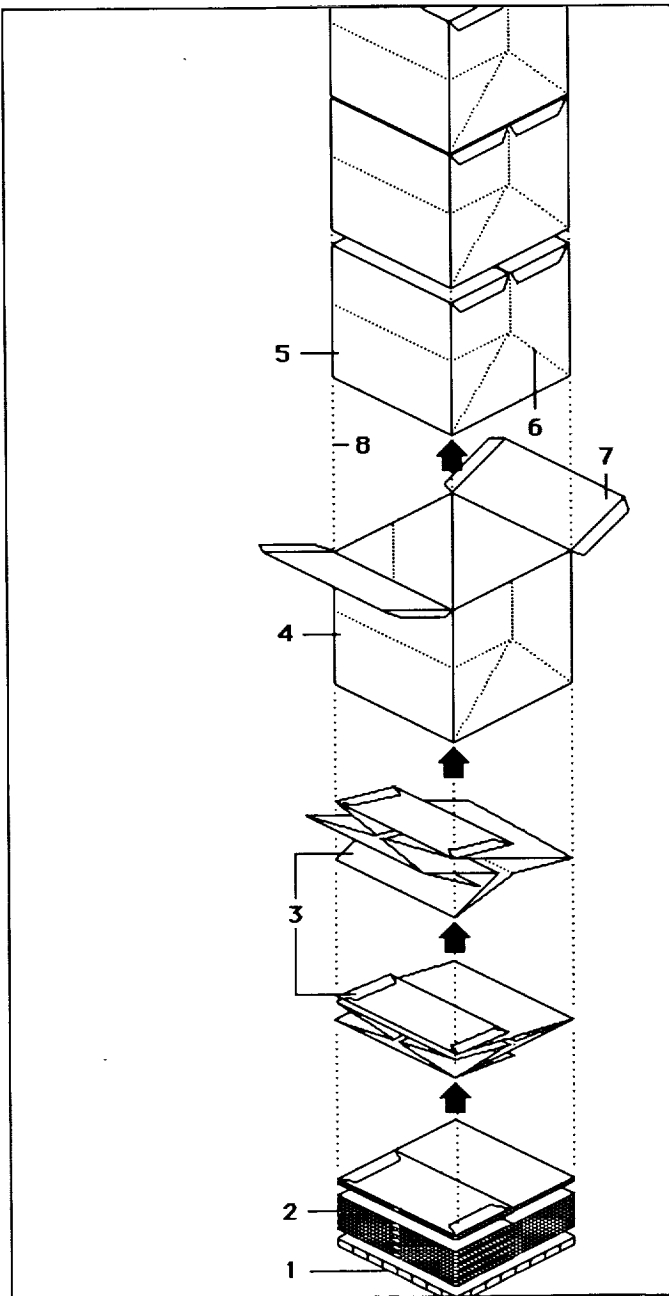

**Fig. 4.** Raising the compartments causes them to unfold from the pallet in a controlled deployment by means of integral cables, as shown here: (1) stack pallet, (2) compartments stowed, (3) compartments unfolded, (4) compartments deployed, (5) compartments secured, (6) fold lines, (7) flaps, and (8) cable lines.

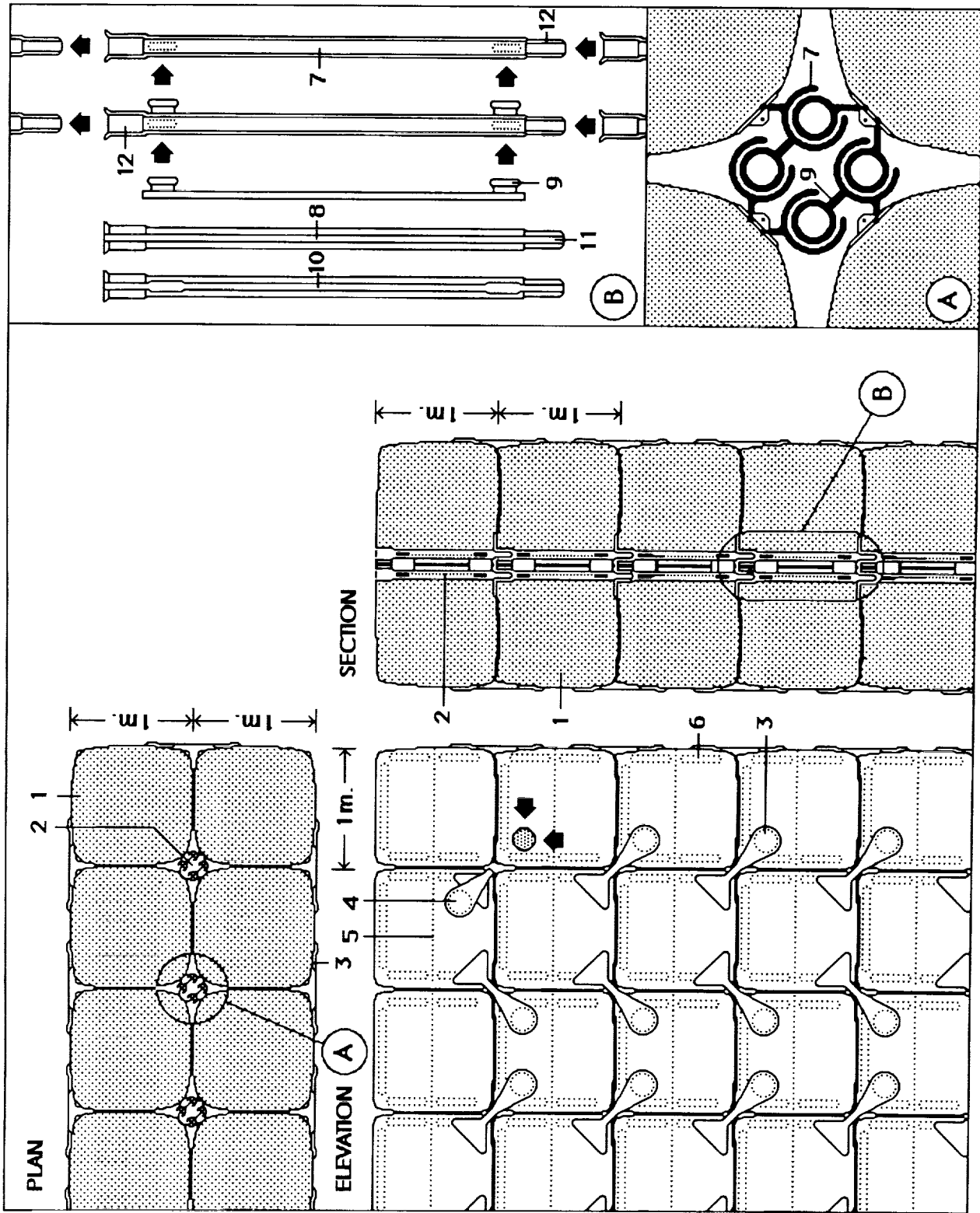

Fig. 5. Preliminary studies are exploring the feasibility of using cubic compartments for the regolith as shown here: (1) filled compartments, (2) interlocking strut assembly, (3) microfastener pad stowed, (4) compartment bag fold lines, (5) integral battens, (6) integral battens, (7) typical strut elevation, (8) interlocking lugs, (9) interlocking lugs, (10) lug tracks, (11) lug tracks, and (12) strut interlocking ends.

measures are required to improve the stability of the wall. Scaled testing is required to establish an equivalent Young's Modulus for the assembly, so that a factor of safety against instability can be established.

As well as compression, the vertical alloy struts and their connectors are required to be designed to carry the weight of six compartments in tension. This loadcase occurs during construction when six filled compartments are suspended by the gantry during the filling of the seventh, lowest compartment. The carbon fiber fabric will be tested to take the pressure from 7 m of regolith.

### INITIAL CONCLUSIONS

The studies demonstrate that (1) vertical shield-walls constructed primarily of raw regolith contained by minimal "delivered" structural elements are a feasible proposition, (2) autonomous "stand-off" shielding eliminates the need for excavation and does not impact systems configurations and operations, and (3) terrestrial civil/structural engineering methodology and analysis procedures adjusted for lunar conditions are appropriate for selective lunar engineering applications.

### FURTHER STUDIES

Studies are needed in the following areas to further evaluate the feasibility of the concept: (1) testing of full-scale model with densities scaled down for feasibility of construction, (2) strength and serviceability testing of carbon fiber fabric options, (3) preliminary detail design of gantry and strut system, (4) assessment of safe bearing pressures on the lunar surface, and (5) assessment of the bulk compaction and cohesion of the regolith.

### REFERENCES

- International Conference of Building Officials (1985) *Uniform Building Code*, pp. 456-467. Whittier, California.
- Kaplicky J. and Nixon D. (1985) A surface-assembled superstructure envelope system to support regolith mass-shielding for an initial-operational-capability lunar base. In *Lunar Bases and Space Activities of the 21st Century* (W. W. Mendell, ed.), pp. 375-380. Lunar and Planetary Institute, Houston.
- NASA (National Aeronautics and Space Administration) (1989) *Man-Systems Integration Standards*. Vol. 1, Rev. A, pp. 5-77 to 5-117. NASA STD-3000.
- Phillips P. G., Simonds C. H., and Stump W. R. (1988) Lunar base launch and landing facilities (abstract). In *Papers Presented to the 1988 Symposium on Lunar Bases and Space Activities of the 21st Century*, p. 194. Lunar and Planetary Institute, Houston.
- Taylor S. R. (1982) *Planetary Science: A Lunar Perspective*, pp. 115-123. Lunar and Planetary Institute, Houston.