

EXTRATERRESTRIAL APPLICATIONS OF SOLAR OPTICS FOR INTERIOR ILLUMINATION

N 9 3 - 1 7 4 4 9

David A. Eijadi and Kyle D. Williams

BRW, Inc.
700 Third Street South
Minneapolis MN 55415

Solar optics is a terrestrial technology that has potential extraterrestrial applications. Active solar optics (ASO) and passive solar optics (PSO) are two approaches to the transmission of sunlight to remote interior spaces. Active solar optics is most appropriate for task illumination, while PSO is most appropriate for general illumination. Research into solar optics, motivated by energy conservation, has produced lightweight and low-cost materials, products that have applications to NASA's Controlled Ecological Life Support System (CELSS) program and its lunar base studies. Specifically, prism light guides have great potential in these contexts. Several applications of solar optics to lunar base concepts are illustrated.

INTRODUCTION

The purpose of solar optic (SO) system design is to enable use of the visible portion of the solar spectrum as a source of general or task illumination and thereby reduce dependence on electrically powered illumination. Passive solar optics (PSO) systems require less precision to design and build and will effectively deliver diffused light as well as beamed light. Active solar optics (ASO) systems effectively deliver beamed light only and need smaller collecting areas but require control systems and a power source.

A sustained effort to develop beamed sunlighting technologies began in 1978 during the "energy crisis." Solar optic technologies were initially developed for concentrating beamed sunlight into remote interiors of Earth-sheltered buildings. The impetus for this research and development, the need for energy conservation, and the applied criteria (lightweight and low-cost materials that minimize volumetric requirements) parallel those of NASA's Controlled Ecological Life Support System (CELSS) program and lunar base applications.

Critical design considerations throughout the development of PSO and ASO systems have included energy conservation, the use of lens designs that do not produce life or safety hazards, ease of construction, weatherability, and optical coatings for selective transmissivity. Wherever possible, nonimaging optics are used in PSO designs. When imaging optics are used, the possibility of conflagration is eliminated through the use of selective filters or containment of focal areas within protective enclosures. Throughout the development of ASO systems, particular attention has been paid to alternatives for heliostat control systems, artificial light sources with integrated controls, and strategies that reduce the volume of optical material required to transport light. Terrestrial and extraterrestrial criteria will no doubt be different; however, many of the lessons learned in developing terrestrial applications are directly transferable.

PASSIVE SOLAR OPTICS

The PSO system is a form of fenestration control that reduces the ratio of aperture size to lighted area in comparison to conventional natural lighting strategies (Eijadi, 1983). The system enables sizing and designing an aperture based on the desired quantity and directionality of the available sunlight. There are two basic types of PSO systems: refractive systems (Fig. 1) and

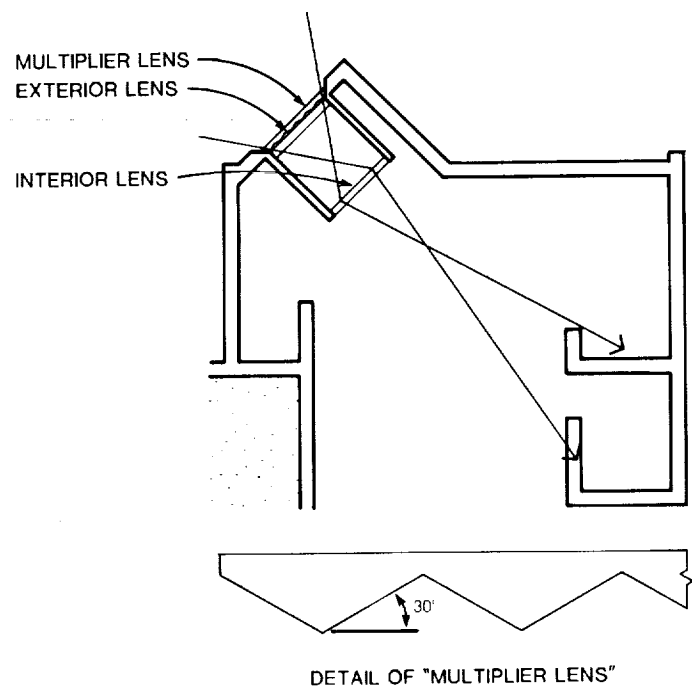

Fig. 1. Refractive PSO system.

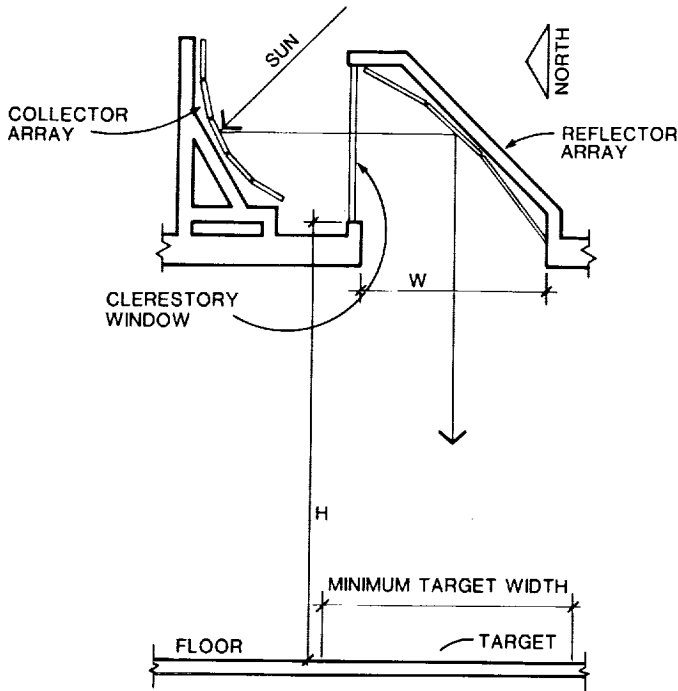

Fig. 2. Reflective PSO system.

reflective systems (Fig. 2). Each system is described in terms of terrestrial applications; however, the same design process applies to extraterrestrial applications. Consideration of filtering undesired radiation and of physically protecting the exterior components needs to be addressed. A meteorite shield with a selective radiation coating similar to that proposed for protecting the heliostat of the CELSS module is worth consideration (Olson and Olson, 1986).

REFRACTIVE PASSIVE SOLAR OPTIC SYSTEM

A refractive PSO system consists of three major elements: (1) interior Fresnel lens; (2) exterior Fresnel lens; and (3) prismatic multiplier lens. The interior and exterior lenses are spaced approximately one focal length apart in an axial arrangement. The multiplier lens is placed ahead of the exterior lens in order to increase the cone of vision in one or both axes altitude and azimuth. Without the multiplier, the limitations of focal length and f-stop generally result in a solid angle cone of view of 32°. The multiplier can double the cone of vision but at the expense of total system efficiency, approximately 12.5% and 6.25%, depending on increasing the cone of view on one or both axes, respectively. The refractive PSO system exhibits some chromatic aberrations. It should be installed at an angle to the ground equal to the latitude of the site for best performance.

REFLECTIVE PASSIVE SOLAR OPTIC SYSTEM

Current installations of the reflective PSO system consist of three major elements: (1) collector array; (2) clerestory window; and (3) reflector array. The collector array faces the sun and reflects sunlight through the clerestory window to the reflector array. The reflector opposes the collector array and redirects the sunlight to the desired target area. Sunlight is diffused approximately 10° when reflected from either array. The pattern of the

Fresnel lenses of the reflector array is turned 90° to that of the collector array so that light is diffused in each direction, resulting in a uniform distribution of light at the target area. An approximate system efficiency, the ratio of illumination reaching the target to the total available on a horizontal surface, can be assumed to be 10% for preliminary design purposes. Empirical testing and a mathematical model were used to estimate overall efficiency (Eijadi, 1983). The effects of dirt, light scattering, diffusion, and absorption in the acrylic contribute to the depreciation of illumination as light is reflected through the arrays. Passive solar optics systems require a separate electrical lighting backup system.

The determination of the angles of repose for each section of the arrays is a function of the latitude the system is designed for and the distance from the system to the target. The topmost panel is aimed at a low horizon. For Earth-based systems, each successively abutting collector panel is aimed higher until all the useful or desired annual solar horizons are within one or more regions of the array. The angles of the reflector array are designed to redirect the light from the collector to the target area.

ACTIVE SOLAR OPTICS

Active solar optics systems are distinguished from PSO systems in that they have a component, a heliostat, that mechanically tracks the solar disk. It is also possible to physically integrate the electrical backup illumination system within the sunlight distribution network. The four components of an ASO system are (1) the heliostat; (2) intermediate transport networks; (3) artificial light sources with controls; and (4) a distribution system (Fig. 3).

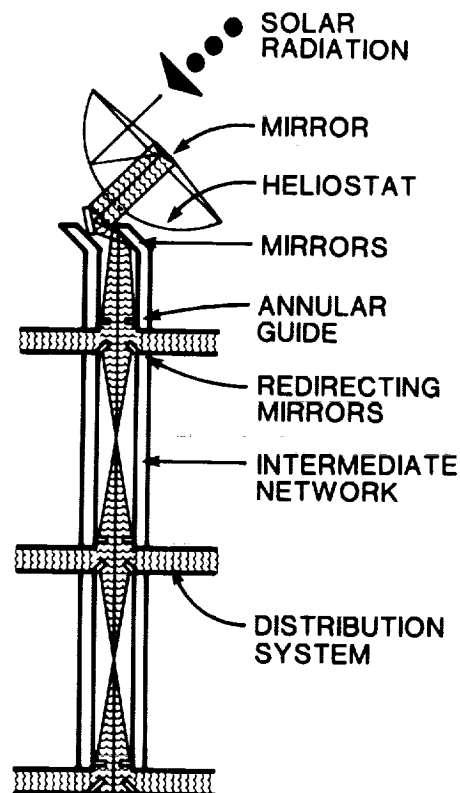

Fig. 3. Active solar optic system.

Simply put, the heliostat tracks the sun and positions a series of reflectors that beam the sunlight into the intermediate transport network. The intermediate network transports the light horizontally or vertically to the delivery device, which illuminates the occupied space.

Various materials were investigated for use in the system (Eijadi *et al.*, 1987). Intermediate network materials included fiber optic cables, reflective pipes, holographic pipes, solid-angle lens guides, and prism light guides (PLG). Distribution devices evaluated included fiber optic cables, diffusing reflectors, specular reflectors, and PLG. Each component was evaluated on the basis of performance, cost, constructibility, and ease of integration with conventional construction practices.

It was concluded that intermediate networks were decidedly best with the least amount of physical material incorporated into their design. They should be dedicated, airtight passageways that are as short as possible. Depending on precise distances, PLG and reflective pipes worked nearly as well. Prism light guides were the preferred choice for the distribution device. Artificial light sources should be high-intensity discharge (HID) sources located as close to the distribution device as possible because the energy for that resource is paid for and should not be subjected to any unnecessary losses prior to utilization. The distribution device (light fixture) should be linear and oriented downward to maximize distribution and minimize room losses associated with absorption and maintenance.

A proof-of-principle model was constructed using the heliostat at the University of Minnesota's Civil and Mineral Engineering building. Sunlight and light from a metal halide source were alternately introduced into the same PLG and produced identical distributions with nearly identical efficiencies. A complete system designed, fabricated, and installed by Whitehead is presently in operation in Toronto, Canada.

Several components of ASO systems have been reduced to common practice. Among those are heliostats, vertical and horizontal distribution networks, and fixtures capable of delivering beamed sunlight and/or electric light. A variety of selective coatings and control systems for heliostats are offered in the marketplace.

PROPERTIES OF MATERIALS USED FOR SOLAR OPTICS

The unique aspect of the work on ASO systems presented in this paper relates to the use of the prism light guides for the transportation and distribution of both sunlight and artificial light. The light guides are hollow tubes made with either an optical grade polycarbonate or acrylic polymer film. The films are called "Scotchlamp Film" by their manufacturer, 3M. The acrylic film is more stable than the polycarbonate, but the polycarbonate can resist higher temperatures, 248°F vs. 190°F. Each film can be made at varying thicknesses but typically is 0.022" (0.56 mm) and weighs about 0.13 lb/ft (0.064 kg/m). The surface of the film is formed into nearly microscopic prismatic facets that transmit light using the principle of total internal reflection (Saxe *et al.*, 1986).

The film used in the PSO system is an optical-grade acrylic similar to that used in the ASO system. It is approximately 0.022" thick (0.56 mm) and comes in widths up to 24" (61 cm). The walls of the film are formed into grooves so that sunlight is reflected with a diffusion of approximately 10%. An aluminum backing is added to the film.

Testing has been performed on similar films exposed to the low-Earth-orbit (LEO) environment (A. Zderad, personal communication, 1988). With the current design, the films degrade in the presence of or impact with monatomic oxygen in LEO. No testing has been performed in deep space. A further investigation of the thermal and ionic space environment in relation to these films is needed in conjunction with a rethinking of the manufacturing process to determine if direct exposure is feasible.

If the films are used in a controlled environment such as the interior of the space station or a lunar base, degradation of the films should not be a problem. Hazards associated with outgassing or fire should be no greater than with any other synthetic materials used.

APPLICATIONS OF SOLAR OPTICS TO SPACE STATION FREEDOM

A conceptual design study clearly identified the need to supplement artificial lighting with solar illumination to grow plants in the CELSS module (Oleson and Olson, 1986). In fact, an all-solar illumination system was preferred, based on a parametric study of electric power, volume, cost, and mass. Unknown plant growth behavior with short illumination cycles prompted the investigation of two hybrid systems, one using a combination of fiber optic cables and fluorescent lamps and the other using fiber optic cables integrated with a remote HID light source.

The hybrid system using fluorescent lamps was identified as the best choice. In this system, a heliostat with an array of 2712 Fresnel lenses concentrates light on 2712 glass fibers that transmit light to the plant-growth units. Solar illumination is utilized during the 60 minutes of available sunlight, and the fluorescent lamps are used during the 30 minutes of darkness each orbit. The fluorescent lamps, adjacent to the plant trays, would provide 750 fc (8070 lux) to the plants and the solar lighting would provide 7500 fc (80,700 lux).

Concerns in using the fluorescent/fiber optic system were identified: (1) mercury in the fluorescent lamps is a health hazard; (2) the fluorescent lamps will have a shorter life span than HID lamps; (3) fluorescent lamp replacement will be more difficult than with a remote HID lamp; and (4) fluorescent lamps cannot be closely spaced because of mutual interference. Each of these concerns was deemed manageable.

The other hybrid system considered in the study utilized HID lights and fiber optic cables. Solar illumination would be transmitted to the plants as before, but a remote HID light source would transmit light via fiber optic cables that would, in turn, be integrated with the cables coming from the heliostat.

Concerns about the HID/fiber optic system include (1) the integration of an HID light source and fiber optic cables is an unknown technology, and significant losses of efficiency were assumed at the interface of the two; (2) higher costs were associated with the HID/fiber optic system, and these costs are directly attributable to the development and design work required by an unknown technology; (3) HID lamps require preheating; and (4) this configuration represented the greatest mass of all the systems evaluated because of additional fiber optic cable required.

The HID/fiber optic system was identified as having the advantages of better maintenance, safety, accessibility, centralized cooling, and lamp efficiency when compared to the fluorescent system.

While two artificial lighting systems were evaluated, only one solar transmission system was evaluated. The use of prism light guides rather than fiber optic cables may offer some opportunities to improve the cost and mass characteristics of the hybrid HID system and utilize the inherent advantages of a remote HID light source. The reasons to consider using prism light guides for this application are (1) The integration of HID lamps and PLG is a known technology, unlike the integration of HID lamps and fiber optics, so a reduction of development costs can be anticipated; (2) PLG can transmit the same amount of light with less optic material, so that assuming the same volumes as the preliminary design, order-of-magnitude calculations reveal that substituting PLG for the fiber optic cables will reduce the mass for the light transfer device by a factor of 50; (3) There exists the opportunity to eliminate the physical connection between the heliostat and CELSS module if the heliostat is mounted on the space station structure for better solar access, and a lens with the proper focal length could concentrate the sun's rays to a porthole on the module; and (4) The system incorporating PLG can filter harmful UV and IR radiation in a similar fashion as fiber optics, which is important when plant growth is concerned (Saxe *et al.*, 1986).

THE APPLICATION OF SOLAR OPTICS TO THE LUNAR BASE

The initial advantage of using ASO for the outpost is the conservation of available space. Longer-range advantages of using SO on the Moon are threefold. First, many concepts for lunar outposts encapsulate habitable areas with regolith or natural formations for protection from harmful radiation. Solar optics provides a way to transmit sunlight to these shielded environments. Second, SO systems can filter out undesired radiation wavelengths, thereby transmitting the desired visible spectrum for interior illumination. Third, the technology is very simple: The heliostat is the only mechanical device used.

The disadvantages of using SO are, first, the need for solar access and, second, the potential loss in efficiency if dust proves to be excessive from lunar operations. Lack of solar access during the lunar night may be mitigated if available luminance from the Earth can be utilized (Ebricke, 1985).

The location of the first lunar site has not been determined. Given this fact we made the assumption that the use of solar energy is desirable wherever the lunar base is located, either as a primary source of power and interior illumination at the lunar poles, or as a secondary source at the lower latitudes of the Moon.

The most promising use of SO would be if a polar location were selected as the initial site for lunar habitation. Because the Moon's equatorial plane is only inclined $1\frac{1}{2}^\circ$ to the ecliptic, there is a possibility for continuous sunlight availability (Burke, 1985). At the lower latitudes, there will be two-week days and two-week nights. In either location, the design of the PSO and ASO systems on the Moon will be modified from Earth-based systems. The small tilt of the lunar axis enables the PSO design emphasis to be placed on tracking the horizontal movement of the sun during the lunar day rather than the vertical, seasonal movement on Earth. Similarly, the ASO design can be simplified by tracking the sun on one axis rather than two.

We have taken several lunar base schemes and speculated on how PSO and ASO might be applied. The schematic diagrams illustrated here represent the stages of lunar development

identified in previous studies (Duke *et al.*, 1985). The diagrams assume a lunar pole location but can be easily modified for any latitude.

Current lighting strategies for the space station habitat and laboratory modules favor the use of all-artificial sources (C. Wheelwright, personal communication, 1988). An opportunity to utilize ASO exists, however, if the habitat modules are used for the first lunar outposts. Figure 4 shows such an outpost (Kaplicky and Nixon, 1985). A preliminary lighting evaluation for the space station identified several interesting concepts (Walter, Dorwin, Teague Assoc., 1987). One concept is to integrate the air plenum, fluorescent lamp, and light diffuser. Removing the fluorescent lamp, the plenum space could be lined with PLG. A heliostat, supplemented with an HID lamp, could then pipe light down the plenum to provide interior illumination. This concept is similar to the one proposed for the CELSS module. As the base incorporates more modules, the ASO system can grow with it.

The scheme shown in Fig. 5 shows housing an operational or advanced base inside a lava tube (Hörz, 1985). This scheme is similar to current terrestrial applications in office buildings. Passive solar optics is used to provide general illumination within the lava tube and ASO is used to provide habitat lighting.

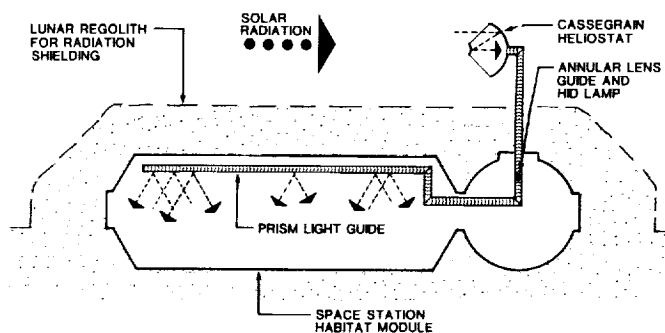

Fig. 4. Lunar outpost using ASO.

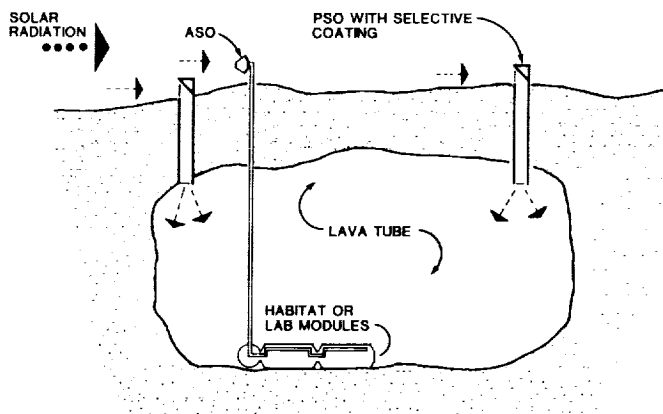

Fig. 5. Operational base using ASO and PSO.

The scheme shown in Fig. 6 is for a self-sufficient colony. The scale of the SO systems is limited only by the available volume. As the lunar community grows, the illumination scheme can grow with it. The diagram shows PSO being used as general illumination and gives a sense of orientation to the colony. Active solar optics is used as building-specific illumination, with light being transmitted both horizontally and vertically.

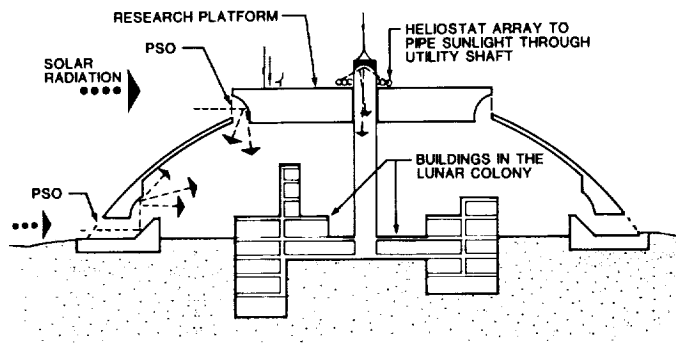

Fig. 6. Self-sufficient colony using ASO and PSO.

CONCLUSION

The SO systems described in this paper are known technologies that have been proven to deliver the quantity and quality of light needed for various human activities on Earth. Active solar optics is most appropriate for general and task illumination, and PSO is most appropriate for general illumination only. Both systems can filter harmful radiation. It is concluded that these same technologies should be considered for use with the space station CELSS module and for the various development phases of the lunar base.

To determine the feasibility of applying SO to extraterrestrial applications, and in particular lunar bases, further investigation as to the effect of the thermal and ionic environment and of lunar dust on the SO system must be undertaken.

REFERENCES

- Burke J. (1985) Merits of a lunar polar base location. In *Lunar Bases and Space Activities of the 21st Century* (W. W. Mendell, ed.), pp. 77-84. Lunar and Planetary Institute, Houston.
- Duke M., Mendell W., and Roberts B. (1985) Strategies for a permanent lunar base. In *Lunar Bases and Space Activities of the 21st Century* (W. W. Mendell, ed.), pp. 57-68. Lunar and Planetary Institute, Houston.
- Ehricke K. (1985) Lunar industrialization and settlement—birth of a polyglobal civilization. In *Lunar Bases and Space Activities of the 21st Century* (W. W. Mendell, ed.), pp. 827-855. Lunar and Planetary Institute, Houston.
- Eijadi D. (1983) The Civil Mineral Engineering building solar optic systems. In *Papers Presented at the Sixth Miami International Conference on Alternate Energy* (T. N. Beziroglu, ed.), pp. 600-603. Clean Energy Research Institute, Miami.
- Eijadi D., Probst D., Shadid W., De Los Rios M., and Bennett D. (1987) *Sunlight Distribution in Remote Interior Locations Using Multi-Axis Suntracker as Light Source*. Contract De-AC02-83ER-80047, U.S. Department of Energy. 125 pp.
- Hörz F. (1985) Lava tubes: Potential shelters for habitats. In *Lunar Bases and Space Activities of the 21st Century* (W. W. Mendell, ed.), pp. 405-412. Lunar and Planetary Institute, Houston.
- Kaplicky J. and Nixon D. (1985) A surface-assembled superstructure envelope system to support regolith mass-shielding for an initial-operational-capability lunar base. In *Lunar Bases and Space Activities of the 21st Century* (W. W. Mendell, ed.), pp. 375-380. Lunar and Planetary Institute, Houston.
- Oleson M. and Olson R. L. (1986) *Controlled Ecological Life Support Systems (CELSS): Conceptual Design Option Study*. NASA Contractor Report 177421, NASA Ames Research Center, Moffett Field. 144 pp.
- Saxe S., Whitehead L., and Cobb S. (1986) Progress in the development of prism light guides. *Proceedings of the Society of Photo-optical Illuminating Engineers*.
- Walter, Dorwin, Teague Assoc. (1987) *Space Station Lighting Evaluation*. Study prepared for Boeing Aerospace Co. 33 pp.