

N 93-13975

# APPLICATIONS FOR SPECIAL-PURPOSE MINERALS AT A LUNAR BASE

Douglas W. Ming

Solar System Exploration Division  
Mail Code SN14  
NASA Johnson Space Center  
Houston TX 77058

*Maintaining a colony on the Moon will require the use of lunar resources to reduce the number of launches necessary to transport goods from the Earth. It may be possible to alter lunar materials to produce minerals or other materials that can be used for applications in life support systems at a lunar base. For example, mild hydrothermal alteration of lunar basaltic glasses can produce special-purpose minerals (e.g., zeolites, smectites, and tobermorites) that in turn may be used in life support, construction, waste renovation, and chemical processes. A variety of zeolites, smectites, feldspars, feldspatoids, and tobermorites have been synthesized by mild hydrothermal alterations of synthetic basaltic glasses with chemical compositions similar to lunar basaltic glasses. Zeolites, smectites, and tobermorites have a number of potential applications at a lunar base. Zeolites are hydrated aluminosilicates of alkali and alkaline earth cations that possess infinite, three-dimensional crystal structures. They are further characterized by an ability to hydrate and dehydrate reversibly and to exchange some of their constituent cations, both without major change of structure. Based on their unique adsorption, cation exchange, molecular sieving, and catalytic properties, zeolites may be used as a solid support medium for the growth of plants, as an adsorption medium for separation of various gases (e.g.,  $N_2$  from  $O_2$ ), as catalysts, as molecular sieves, and as a cation exchanger in sewage-effluent treatment, in radioactive waste disposal, and in pollution control. There are other possible applications for zeolites at lunar or other planetary bases, but they are too numerous to report here. Smectites are crystalline, hydrated 2:1 layered aluminosilicates that also have the ability to exchange some of their constituent cations. Like zeolites, smectites may be used as an adsorption medium for waste renovation, as adsorption sites for important essential plant growth cations in solid support plant growth mediums (i.e., "soils"), as cation exchangers, and in other important applications. However, the potential use of smectites at a lunar base may be less favorable than the use of zeolites, because zeolites have up to five times more capacity to exchange cations than smectites. Tobermorites are crystalline, hydrated single-chained layered silicates that have cation-exchange and selectivity properties between those of smectites and most zeolites. Tobermorites may be used as a cement in building lunar base structures, as catalysts, as media for nuclear and hazardous waste disposal, as exchange media for waste-water treatment, and in other potential applications. Special-purpose minerals synthesized at a lunar base may also have important applications at a space station and for other planetary missions. For example, zeolites or tobermorites might be used in waste renovation on the space station, or wastes may be sent to the lunar surface and processed at a lunar base that uses these special-purpose minerals for waste recycling. New technologies will be required at a lunar base to develop life support systems that are self-sufficient, and the use of special-purpose minerals may help achieve this self-sufficiency.*

## INTRODUCTION

The human exploration of our solar system is rapidly approaching as space agencies in the U.S., the U.S.S.R., Japan, China, and Europe are in the planning stages of advanced planetary missions. The first step in establishing a permanent human colony away from Earth may be the shortest: to the Moon. A number of reasons to colonize the Moon have been suggested, including scientific research, exploitation of lunar resources for use in building a space infrastructure, and attainment of self-sufficiency in the lunar environment as a first step in planetary exploration (Duke et al., 1985). The close proximity of the Moon to the Earth also makes a lunar base attractive over other potential planetary bases. The lunar environment is one of the most barren environments for human existence when comparing our near neighbors in the solar system (e.g., Mars). Thus, the development of self-sufficient colonies on the Moon will greatly enhance the probability of the survival of a human colony on a more distant planetary body.

A self-sufficient lunar colony will require the use of lunar resources. Common constituents of the lunar regolith are silicate minerals (e.g., pyroxenes, olivines, feldspars), iron-titanium oxides (e.g., ilmenite), glass materials, and agglutinates (complex mixtures of glass and mineral fragments). The lunar regolith lacks ion-exchange minerals such as clay minerals (e.g., smectites) and zeolites. Components of the lunar regolith in their present state will probably not have very many applications, except to be used as shielding from solar radiation. It is likely that lunar materials (e.g., glass) will be altered to produce minerals and other materials with ion-exchange behaviors that can be used for applications in life support systems. These reactive minerals that may have potential uses at a lunar base have been called "special-purpose minerals" in this paper.

## SPECIAL-PURPOSE MINERALS

Three major groups of minerals may be of interest to scientists and engineers as they design lunar base structures and life support systems. These special-purpose minerals are (1) zeolites,

TABLE 1. Representative unit-cell formulae and selected physical and chemical properties of important special-purpose minerals.

Special-Purpose Minerals	Representative Unit-Cell Formula <sup>a, *</sup>	Void Volume (%)	Cation Exchange Capacity meq/100 g
<i>Zeolites</i>			
Analcime	Na <sub>16</sub> {Al <sub>16</sub> Si <sub>32</sub> O <sub>96</sub> }·16H <sub>2</sub> O	18	460
Chabazite	(Na <sub>2</sub> Ca) <sub>6</sub> {Al <sub>12</sub> Si <sub>24</sub> O <sub>72</sub> }·40H <sub>2</sub> O	47	420
Clinoptilolite	(Na <sub>4</sub> K <sub>3</sub> ){Al <sub>6</sub> Si <sub>30</sub> O <sub>72</sub> }·24H <sub>2</sub> O	34	220
Mordenite	Na <sub>8</sub> {Al <sub>8</sub> Si <sub>40</sub> O <sub>96</sub> }·24H <sub>2</sub> O	28	220
Phillipsite	(Na,K) <sub>5</sub> {Al <sub>5</sub> Si <sub>11</sub> O <sub>32</sub> }·20H <sub>2</sub> O	31	380
Linde Type A	Na <sub>96</sub> {Al <sub>96</sub> Si <sub>96</sub> O <sub>384</sub> }·216H <sub>2</sub> O	47	540
Linde Type X	Na <sub>96</sub> {Al <sub>86</sub> Si <sub>106</sub> O <sub>384</sub> }·264H <sub>2</sub> O	50	470
<i>Phyllosilicates</i>			
Vermiculite	(Mg,Fe) <sub>3</sub> (Al <sub>0.4</sub> Si <sub>3.6</sub> )O <sub>10</sub> (OH) <sub>2</sub> ·nH <sub>2</sub> OMg <sub>0.8</sub>	—	160 <sup>†</sup>
Smectite <sup>‡</sup>	(Al <sub>1.5</sub> Mg <sub>0.5</sub> )Si <sub>4</sub> O <sub>10</sub> (OH) <sub>2</sub> ·nH <sub>2</sub> OCa <sub>0.25</sub>	—	110 <sup>‡</sup>
<i>Tobermorites</i>			
Tobermorite	Ca <sub>5</sub> Si <sub>6</sub> H <sub>2</sub> O <sub>18</sub> ·4H <sub>2</sub> O	—	<15
Al-Substituted Tobermorite	Ca <sub>5</sub> (Al,Si) <sub>6</sub> O <sub>18</sub> ·nH <sub>2</sub> ONa <sub>x</sub>	—	182 <sup>§</sup>

<sup>a</sup> Taken mainly from Breck (1974).

<sup>†</sup> Montmorillonite.

<sup>‡</sup> Alexiades and Jackson (1965).

<sup>§</sup> Komarneni and Roy (1983).

(2) phyllosilicates, and (3) tobermorites. Several natural and synthetic minerals of these groups along with representative unit cell formulae are listed in Table 1.

### Zeolites

Zeolites were discovered in 1756 by the Swedish mineralogist Cronstedt who named them from the Greek words *zein* and *litbos*, meaning "boiling stones." Since that time there have been about 50 natural zeolites discovered, and several hundred synthetic species have been made in the laboratory. Zeolites are hydrated aluminosilicates of alkali and alkaline Earth cations (e.g., K<sup>+</sup>, Na<sup>+</sup>, Ca<sup>2+</sup>, Mg<sup>2+</sup>) that possess infinite three-dimensional crystal structures (i.e., tektosilicates).

The primary building units of the zeolite crystal structure are (Al,Si)O<sub>4</sub> tetrahedra. When Al<sup>3+</sup> and sometimes Fe<sup>3+</sup> substitute for Si<sup>4+</sup> in the central cation position of the tetrahedron, a net negative charge is generated. This negative charge is counterbalanced primarily by alkali and alkaline Earth cations (generally called "exchange cations"). The exchange cations are loosely held near the seat of charge within the zeolite structure and can be replaced by other cations in solution. Natural zeolites may have measured cation exchange capacities (CEC) of 200-300 meq/100 g, whereas synthetic zeolites may have a CEC as high as 500-600 meq/100 g.

Zeolites may have void volumes within their structures of up to 50% when dehydrated. Because of these large void volumes, zeolites are able to hydrate, dehydrate, and adsorb a wide variety of molecules without causing any changes to their crystal structure. Zeolites also have unique molecular sieving and catalytic properties. The occurrence, structures, and properties of natural zeolites have been presented by Mumpton (1981), Sand and Mumpton (1978), Gottardi and Galli (1985), and Ming and Mumpton (1989). Structures and properties of synthetic zeolites are described by Breck (1974).

### Phyllosilicates

The term phyllosilicate was derived from the Greek word *phyllon*, which means "leaf," because most of the minerals in this group have a platy or flaky habit. Most of the members of this class of aluminosilicates consist either of 2:1 layered minerals (i.e., 1 tetrahedral sheet : 1 octahedral sheet : 1 tetrahedral sheet) or 1:1 layered minerals (i.e., 1 tetrahedral sheet : 1 octahedral sheet).

Because of their cation-exchange behavior, smectites and vermiculites should be of interest to scientists concerned with applications of phyllosilicates at a lunar base. Smectites and vermiculites are 2:1 layered minerals that have a net negative charge generated by isomorphic substitutions in their 2:1 layers. The negative charge is counterbalanced by hydrated cations located in the interlayer between the 2:1 layers. Smectites and vermiculites, like zeolites, have the capability of exchanging some of their constituent cations with cations from solution; however, the structure in 2:1 layered minerals is not as rigid as the zeolite structure. Generally, smectites will expand in the interlayer depending on the molecule type and on the hydration of the system, whereas vermiculites somewhat restrict interlayer expansion. Vermiculites are higher charge materials (e.g., 140-160 meq/100 g) than smectites (e.g., 80-105 meq/100 g).

The occurrence, structures, and properties of phyllosilicates are described in Grim (1968), Brindley and Brown (1980), and Dixon and Weed (1989).

### Tobermorites

Tobermorite, a rare hydrous silicate mineral, was discovered by Heddle in 1880. The crystal structures of tobermorites are not well known. It is known, however, that they have a layered structure similar to 2:1 phyllosilicates. A distorted, central calcium oxide octahedral sheet is flanked on both sides by single chains of silicate tetrahedra. Anomalous tobermorites have numerous Si-

O-Si bridges between adjacent silicate chains in the interlayer, whereas normal tobermorites only have a few Si-O-Si bridges in the interlayer. These Si-O-Si bridges form "interlayer" bridges that are similar to the tunnels in zeolites (Komarneni and Guggenheim, 1988). In synthetic systems, it is possible to substitute  $\text{Al}^{3+}$  or  $\text{Fe}^{3+}$  for  $\text{Si}^{4+}$  in the central tetrahedral cation site. As in zeolites, a net negative charge is generated in these Al- or Fe-substituted tobermorites. The negative charge is counterbalanced by various cations (e.g.,  $\text{Na}^+$ ,  $\text{Ca}^{2+}$ ,  $\text{Cs}^+$ ), and it is therefore possible to exchange cations on these sites with cations in solution. Komarneni *et al.* (1987) have shown that Al-substituted synthetic tobermorites are selective for  $\text{Cs}^+$  over  $\text{Na}^+$  and  $\text{Ca}^{2+}$  on the exchange sites. The CECs of synthetic tobermorites depend on the degree of Al- and Fe-substitution for Si. Komarneni and Roy (1983) found that Al-substituted synthetic tobermorites had CECs as high as 182 meq/100 g.

The hydration/dehydration properties of tobermorite are somewhat different from 2:1 phyllosilicates and zeolites. Unlike smectites, dehydrated normal tobermorites collapse and then do not rehydrate (El-Hemaly *et al.*, 1977). However, anomalous tobermorites, which have numerous Si-O-Si bridges in the interlayer, do not collapse when dehydrated because the bridges keep them open.

The structures and properties of tobermorites are described in Taylor (1964), Komarneni and Roy (1983), and El-Hemaly *et al.* (1977).

## SYNTHESIS OF SPECIAL-PURPOSE MINERALS

Special-purpose minerals do not exist in the lunar regolith due to the lack of water, which is necessary to form these minerals. However, zeolites, smectites, and tobermorites have been synthesized under mild hydrothermal conditions from synthetic basaltic glass with chemical compositions similar to lunar basaltic glasses (Ming and Lofgren, 1990). Basaltic glass is abundant in many lunar "soils" (Williams and Jadwick, 1980); therefore, it is probable that special-purpose minerals can be easily synthesized from lunar regolith.

A number of zeolites and other mineral phases have been synthesized from terrestrial basaltic glasses. For example, Höller and Wirsching (1978) have hydrothermally altered terrestrial basaltic glass with  $\text{H}_2\text{O}$  and  $\text{NaOH}$  solutions to form the zeolites chabazite, phillipsite, and analcime. In another study (Wirsching, 1981), basaltic glass altered with  $\text{CaCl}_2$  solutions formed several zeolites (phillipsite, scolecite, wairakite, and levynite) and minor amounts of montmorillonite.

The hydrothermal synthesis of zeolite molecular sieves from reagent-grade chemicals has been commonplace in industry over the past 30 years. The production of chemically pure oxides and other chemical reagents from lunar materials may be necessary for industrial uses on the Moon. Hence, the synthesis of zeolites and other minerals from chemical reagents should not be a problem. A comprehensive review of zeolite synthesis is found in Barrer (1982).

The major resource necessary for the synthesis of special-purpose minerals that will be lacking on the lunar surface is water. Water will have to be transported to the Moon from the Earth, or will have to be made on the lunar surface from regolith oxygen (Williams, 1985; Gibson and Knudsen, 1985; Cutler and Krag, 1985) and solar wind implanted hydrogen (Carter, 1985; Tucker *et al.*, 1985; Blanford *et al.*, 1985). Power requirements to heat the samples should be small. In fact, the month-long lunar day

at the equatorial region may reach temperatures as high as  $120^\circ\text{C}$ . Temperatures around  $120^\circ\text{C}$  may be high enough to form special-purpose minerals by altering the glass material from the regolith under mild hydrothermal conditions.

## APPLICATIONS OF SPECIAL-PURPOSE MINERALS

Because of their unique cation-exchange, adsorption, hydration-dehydration, and catalytic properties, special-purpose minerals are being used in a wide variety of industrial and agricultural processes, although the use of these minerals for agricultural applications is in its infancy. Basic research is just now supplying the necessary information on the various properties that make these reactive minerals attractive for agricultural purposes. As our knowledge on the properties of special-purpose minerals grows, not only will their use in terrestrial processes increase, but their possible uses at planetary bases will become more evident.

### Zeolites

The zeolite group of minerals may be the most attractive of the special-purpose minerals for use at a lunar base. Zeolites are some of the most effective cation exchangers known and they are relatively easy to synthesize at low temperatures and pressures. The use of zeolites may be most advantageous in controlled ecological life support systems (CELSS).

**Zeoponics.** Zeoponics is only in its developmental stages and is defined as the cultivation of plants in zeolite substrates that (1) contain essential plant growth cations on their exchange sites and (2) have minor amounts of mineral phases (e.g., apatite) or anion exchange resins (e.g., activated aluminum) that supply essential plant growth anions (e.g.,  $\text{H}_2\text{PO}_4^{2-}$ ) (Ming, 1989). A zeoponics system is illustrated in Fig. 1.

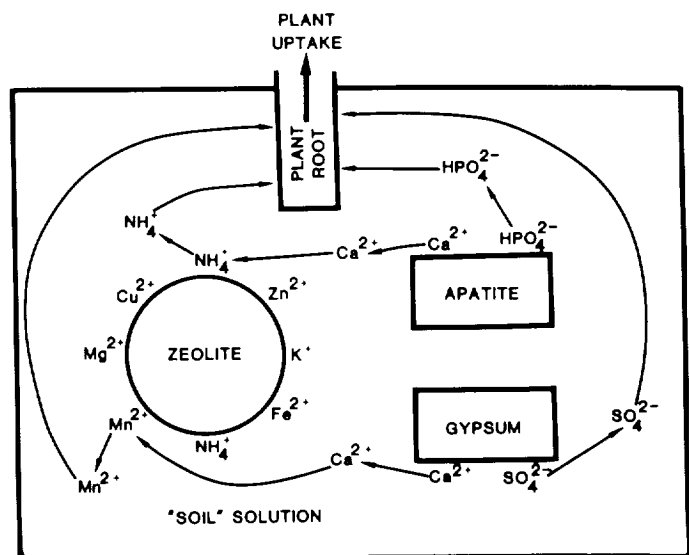

Fig. 1. Zeoponic system for plant growth. Apatite and gypsum undergo dissolution at their surfaces, releasing  $\text{Ca}^{2+}$ ,  $\text{HPO}_4^{2-}$ , and  $\text{SO}_4^{2-}$  into solution. The  $\text{Ca}^{2+}$  competes with and replaces cations on zeolitic exchange sites, releasing plant-essential cations into solution for plant uptake. The  $\text{HPO}_4^{2-}$  and  $\text{SO}_4^{2-}$  also are available for plant uptake.

The use of zeolites as amendments to soils to increase plant fertility is not a new idea (see *Ming*, 1989); however, little has been done using zeolites as a substrate by themselves. The high CEC of zeolites will aid in holding essential plant growth cations until the plant requires these nutrients. Although little information is available, *Stoilov and Popov* (1982) reported the use of clinoptilolite (a highly siliceous zeolite) as a raw material for plant substrates. The zeolitic substrate was found to act as a reservoir for nutrient cations, to have desirable strength and other physical properties, to be sterile with respect to pathogenic microorganisms, and to be aesthetically pleasing. Depending on the plant variety, 20-150% increases in yields over control plots were observed for tomatoes, strawberries, peppers, and rice. Also, the ripening of rice, cotton, and tomatoes was accelerated in the zeolite substrate.

Zeoponics may rival hydroponics or aeroponics in plant production. Plants will be a key to sustaining a crew at a self-sufficient lunar base, and zeolites deserve further consideration as a substrate in which to grow plants.

**Wastewater recycling.** Water will be a precious commodity at a lunar base; therefore, it is essential that water be recycled. Zeolites have been used for cation-exchange resins in water purification for the past 50 years. For example, some zeolites are highly selective for ammonium ions and can be used to remove ammonium in secondary effluents from urban sewage (*Mercer et al.*, 1970; *Jorgensen et al.*, 1976; *Liberti et al.*, 1979). Of the various methods to remove  $\text{NH}_4^+$  from terrestrial wastewaters (*Jorgensen et al.*, 1976), zeolites appear to be the best choice for use at a lunar base.

Zeolites should be able to remove cations other than  $\text{NH}_4^+$ , e.g.,  $\text{Cs}^+$ ,  $\text{Rb}^+$ ,  $\text{Sr}^{2+}$ ,  $\text{Pb}^+$ ,  $\text{Zn}^{2+}$ , etc. from wastewaters at a lunar base. It should be possible to synthesize a specific zeolite that is highly selective for a given cation in lunar wastewaters. Once the zeolite exchange column has been spent (i.e., saturated), the column can be chemically regenerated and reused. A potential wastewater purification system at a lunar base is illustrated in Fig. 2.

**Gas separation purification.** Gas exchange in a CELSS will have to be rigidly monitored. Slight variations in gas mixtures may be detrimental to crew and plant life. Zeolites have void volumes of 20-50%, and dehydrated zeolite structures are effective sorbents of gases. Various zeolite species have the capability to remove specific gases (e.g.,  $\text{SO}_2$ ,  $\text{CO}_2$ ,  $\text{N}_2$ ,  $\text{H}_2\text{S}$ ,  $\text{H}_2\text{O}$ ) from gas streams. For example, natural chabazite and synthetic molecular-sieve zeolite NaX are used to remove  $\text{CO}_2$  and  $\text{H}_2\text{O}$  from industrial gases (*Mumpton*, 1975; *Webber*, 1972). Once adsorbed on the zeolite, the gases can be removed by pressure-swing desorption cycles and reused for gas separation.

The flow diagram in Fig. 3 illustrates a potential lunar base gas separation process (after *Minato and Tamura*, 1978) for a system containing  $\text{H}_2\text{O}$ ,  $\text{O}_2$ ,  $\text{N}_2$ , and  $\text{CO}_2$ . First, water and  $\text{CO}_2$  are removed from the gas stream by pretreatment columns containing zeolites (e.g., clinoptilolite) that are selective for dipolar gases. Next the air stream is fed into columns containing zeolites (e.g., zeolite Ca-A, mordenite, chabazite) that selectively adsorb quadrupolar  $\text{N}_2$ . Oxygen passes through the zeolite columns into an oxygen holding tank (*Stewart and Heck*, 1969). Nitrogen is removed from the zeolite column by a pressure-swing desorption process. The series of three pretreatment columns and zeolite columns allows continuous production of  $\text{O}_2$  and  $\text{N}_2$  by alternating between columns one, two, and three.

**Other applications.** Applications for zeolites at a lunar base are numerous. Because of their unique properties, they can be

used as catalysts and adsorbents (e.g., *Boreskov and Minachev*, 1979; *Breck*, 1974; *Weisz*, 1980; *Rabo*, 1976). The use of zeolites for other terrestrial industrial and agricultural applications has been reviewed extensively elsewhere (e.g., see *Sand and Mumpton*, 1978; *Pond and Mumpton*, 1984; *Townsend*, 1980; *Murakami et al.*, 1986; *Drzaj et al.*, 1985).

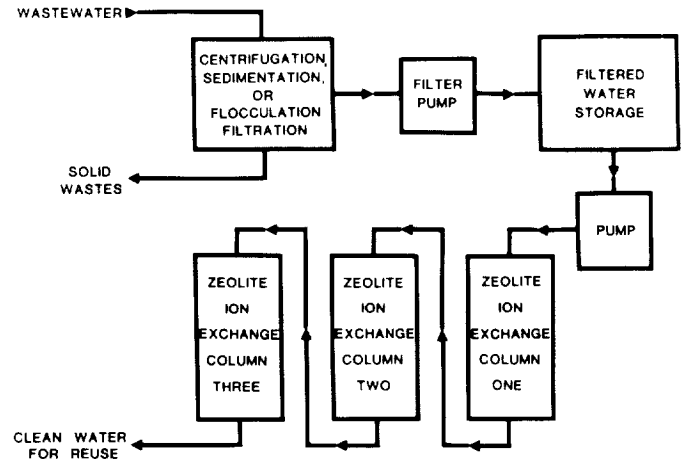

Fig. 2. Wastewater recycling system using zeolites to remove  $\text{NH}_4^+$  and other undesirable cations.

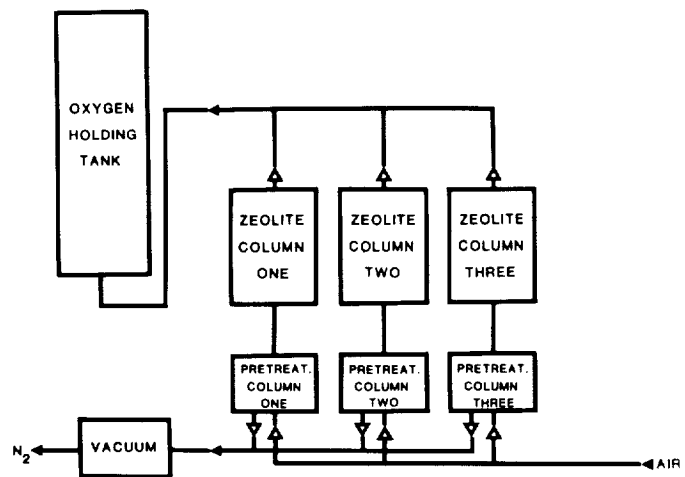

Fig. 3. Schematic diagram of a gas separation system for  $\text{O}_2$ ,  $\text{N}_2$ ,  $\text{CO}_2$ , and water (after *Minato and Tamura*, 1978).

## Phyllosilicates

Smectites appear to be the most favorable phyllosilicate to use at a lunar base because of their cation-exchange properties. However, the potential use of smectites at a lunar base may be somewhat less favorable than the use of zeolites, which have up to five times more capacity to exchange cations than smectites. Nevertheless, smectites are responsible for a large portion of the CEC in terrestrial soils (Borchardt, 1977). These smectitic cation exchange sites in soils create sites to hold fertilizer cations such as  $K^+$ ,  $NH_4^+$ ,  $Ca^{2+}$ ,  $Mg^{2+}$ ,  $Zn^{2+}$ , and  $Fe^{2+}$ . The addition of a CEC mineral to lunar soils in order to produce a soil for plant growth at a lunar base was one of the major recommendations from a NASA workshop entitled "Lunar soils for the growth of higher plants" (Ming and Henninger, 1989). Smectites appear to be one of the best minerals to add to lunar materials to produce a reactive and productive soil. Also, calcined smectite (i.e., aggregates of clay particles heated to high temperatures) forms hardened particles, and, when mixed with other components (e.g., quartz sand, soil, peat moss), makes a productive terrestrial root medium. The irregular shape of the particles creates large pores for aeration and drainage. Calcined smectites also have sizable CECs (e.g., as high as 25 meq/100 g), which results in good nutrient retention. A productive lunar soil may consist of calcined smectite combined with lunar materials (e.g., sand-sized feldspars).

Expanded vermiculites are widely used as potting media. Water between clay particles causes expansion when the particles are heated. The expanded volume can be up to 16 times larger than the original mineral. Expanded vermiculites are very desirable solid-support substrates for plant growth because of their nutrient and water retention, good aeration, and low bulk densities. Vermiculite solid-support media may act as excellent soils for plant growth on the Moon; however, it is fairly difficult to synthesize vermiculites. Vermiculites are generally formed by the accelerated weathering of micas as an extension of the natural process on Earth.

Phyllosilicates also can adsorb various gases and molecules on external and internal surfaces, but to a lesser extent than most zeolites. However, phyllosilicates, especially smectites, have important industrial applications as sorbents (Barrer, 1978). For example, amino acids are sorbed from aqueous solution by Na-, Ca-, and H-saturated smectites (Greenland et al., 1962; Talibudeen, 1955). Also  $CO_2$  and  $N_2$  will adsorb on external surfaces of smectites (Fripjat et al., 1974), and organic acids (e.g., humic and fulvic acids) may be adsorbed in the interlayers of smectites (Mortland, 1970). Smectites may perhaps be most useful in the removal of various organics from wastewaters at lunar bases.

## Tobermorites

Tobermorite has been identified as the principal binding agent in autoclaved cement products (Kalousek, 1955). Also, poorly crystalline tobermorite-like minerals (e.g., "ill-crystallized" tobermorites) are major phases in cement hydration (Taylor, 1964). Concrete has been suggested as a suitable structure to house facilities and personnel at a lunar base (Lin, 1985; Young, 1985). Lunar concrete structures are capable of withstanding the effects of temperatures, solar wind, radiation, cosmic rays, and micrometeorites (Lin, 1985). Lin et al. (1988) have also shown that actual lunar material works quite well as an aggregate for

concrete. However, lunar raw materials have not been used to produce cement. Since tobermorite can be readily synthesized from lunar basaltic analog glass (Ming and Lofgren, 1990), it may be possible to use lunar basaltic glass as a cement precursor and heat ( $\sim 160^\circ C$ ) the glass, solution, and aggregate under mild hydrothermal conditions to produce a concrete.

Aluminum- and Fe-substituted tobermorites also exhibit significant cation exchange capacities (Komarneni et al., 1982, 1987; Komarneni and Roy, 1983; Pannaparayil et al., 1985). Tobermorites are being investigated for their terrestrial applications in catalysis and in nuclear and hazardous waste disposal (Komarneni and Roy, 1983). Nuclear energy may play a major role in the development of lunar bases (Buden and Angelo, 1985; French, 1985). If nuclear energy is to be used as a power source on the Moon, it will be necessary to shield the reactor and provide for safe disposal or storage of nuclear wastes. Since tobermorites are highly selective for radioactive waste cations (e.g.,  $^{137}Cs^+$ ), concretes with tobermorites as the primary binding agent may act as substrates to trap and store radioactive cations.

## WHY SPECIAL-PURPOSE MINERALS?

Organic ion exchangers (e.g., polystyrene divinylbenzene) are in widespread use in industry, along with zeolite ion exchangers. The production of organic ion exchange materials at a lunar base may be difficult because of the small quantities of organic compounds in the lunar regolith. Hence, the lack of organic molecules further supports the use of inorganic zeolites (and, possibly, tobermorites and smectites) as ion exchangers at lunar bases.

Zeolites, smectites, and tobermorites are relatively easy to synthesize from glass-starting materials. A wealth of information is available on zeolite synthesis; therefore, it should be fairly easy to produce zeolite (or tobermorite) species that will cater to particular needs.

Special-purpose minerals may have a wide variety of applications, from construction materials to plant growth substrates. The terrestrial use of special-purpose minerals is only in its infancy and, no doubt, as the science grows, the uses for special-purpose minerals at lunar bases will become more evident.

## REFERENCES

- Alexaides C. A. and Jackson M. L. (1965) Quantitative determination of vermiculite in soils. *Soil Sci. Soc. Am. Proc.*, 29, 522-527.
- Barrer R. M. (1978) *Zeolites and Clay Minerals as Sorbents and Molecular Sieves*. Academic, New York. 497 pp.
- Barrer R. M. (1982) *Hydrothermal Chemistry of Zeolites*. Academic, London. 360 pp.
- Blanford G. E., Borgesen P., Maurette M., Moller W., and Monart B. (1985) Hydrogen and water desorption on the Moon: Approximate, on-line simulations. In *Lunar Bases and Space Activities of the 21st Century* (W. W. Mendell, ed.), pp. 603-609. Lunar and Planetary Institute, Houston.
- Borchardt G. A. (1977) Montmorillonite and other smectite minerals. In *Minerals in Soil Environments* (J. B. Dixon and S. B. Weed, eds.), pp. 293-330. Soil Science Society of America, Madison.
- Boreskov G. K. and Minachev Kh. M., eds. (1979) *Applications of Zeolites in Catalysis*. Akadémiai Kiadó, Budapest. 179 pp.
- Breck D. W. (1974) *Zeolite Molecular Sieves*. Wiley, New York. 771 pp.
- Brindley G. W. and Brown G. (1980) *Crystal Structures of Clay Minerals and Their X-ray Identification*. Mineralogical Society, London. 495 pp.

- Buden D. and Angelo J. A. (1985) Nuclear energy—Key to lunar development. In *Lunar Bases and Space Activities of the 21st Century* (W. W. Mendell, ed.), pp. 85-98. Lunar and Planetary Institute, Houston.
- Carter J. L. (1985) Lunar regolith fines: A source of hydrogen. In *Lunar Bases and Space Activities of the 21st Century* (W. W. Mendell, ed.), pp. 571-581. Lunar and Planetary Institute, Houston.
- Cutler A. H. and Krag P. (1985) A carbothermal scheme for lunar oxygen production. In *Lunar Bases and Space Activities of the 21st Century* (W. W. Mendell, ed.), pp. 559-569. Lunar and Planetary Institute, Houston.
- Dixon J. B. and Weed S. B., eds. (1989) *Minerals in Soil Environments, 2nd edition*. Soil Science Society of America, Madison. 1244 pp.
- Drzaj B., Hocevar S., and Pejovnik S. (1985) *Zeolites: Synthesis, Structure, Technology, and Applications*. Elsevier, New York. 690 pp.
- Duke M. B., Mendell W. W., and Roberts B. B. (1985) Strategies for a permanent lunar base. In *Lunar Bases and Space Activities of the 21st Century* (W. W. Mendell, ed.), pp. 57-68. Lunar and Planetary Institute, Houston.
- El-Hemaly S. A. S., Mitsuda T., and Taylor H. F. W. (1977) Synthesis of normal and anomalous tobermorites. *Cem. Concr. Res.*, 7, 429-438.
- French J. R. (1985) Nuclear powerplants for lunar bases. In *Lunar Bases and Space Activities of the 21st Century* (W. W. Mendell, ed.), pp. 99-106. Lunar and Planetary Institute, Houston.
- Fripiat J. J., Cruz M. I., Bohor B. F., and Thomas J. (1974) Interlamellar adsorption of carbon dioxide by smectites. *Clays Clay Miner.*, 22, 23-30.
- Gibson M. A. and Knudsen C. W. (1985) Lunar oxygen production from ilmenite. In *Lunar Bases and Space Activities of the 21st Century* (W. W. Mendell, ed.), pp. 543-550. Lunar and Planetary Institute, Houston.
- Gottardi G. and Galli E. (1985) *Natural Zeolites*. Springer-Verlag, New York. 409 pp.
- Greenland D. J., Laby R. H., and Quirk J. P. (1962) Adsorption of glycine and its di-, tri-, and tetra-peptides by montmorillonite. *Trans. Faraday Soc.*, 58, 829-841.
- Grim R. E. (1968) *Clay Mineralogy*. McGraw-Hill, New York. 596 pp.
- Höller H. and Wirsching U. (1978) Experiments on the formation of zeolites by hydrothermal alteration of volcanic glasses. In *Natural Zeolites: Occurrence, Properties, Use* (L. B. Sand and F. A. Mumpton, eds.), pp. 329-336. Pergamon, New York.
- Jorgensen S. E., Libor O., Lea Graber K., and Barkacs K. (1976) Ammonia removal by use of clinoptilolite. *Water Res.*, 10, 213-224.
- Kalousek G. L. (1955) Tobermorite and related phases in the system CaO-SiO<sub>2</sub>-H<sub>2</sub>O. *J. Am. Concr. Inst.*, 26, 989-1011.
- Komarneni S. and Guggenheim S. (1988) Comparison of cation exchange in ganophyllite and [Na+Al]-substituted tobermorite: Crystal-chemical implications. *Mineral. Mag.*, 52, 371-375.
- Komarneni S. and Roy D. M. (1983) Tobermorites: A new family of cation exchangers. *Science*, 221, 647-648.
- Komarneni S., Roy D. M., and Roy R. (1982) Al-substituted tobermorite: Shows cation exchange. *Cem. Concr. Res.*, 12, 773-780.
- Komarneni S., Breval W., Miyake M., and Roy R. (1987) Cation-exchange properties of (Al+Na)-substituted synthetic tobermorites. *Clays Clay Miner.*, 35, 385-390.
- Liberti L., Boari G., and Passino R. (1979) Phosphates and ammonia recovery from secondary effluents by selective ion exchange with production of a slow-release fertilizer. *Water Res.*, 13, 65-73.
- Lin T. D. (1985) Concrete for lunar construction. In *Lunar Bases and Space Activities of the 21st Century* (W. W. Mendell, ed.), pp. 381-390. Lunar and Planetary Institute, Houston.
- Lin T. D., Love H., and Stark D. (1988) Physical properties of concrete made with Apollo 16 lunar soil sample (abstract). In *Papers Presented to the 1988 Symposium on Lunar Bases and Space Activities of the 21st Century*, p. 159. Lunar and Planetary Institute, Houston.
- Mercer B. W., Ames L. L., Touhill C. J., Van Slyke W. J., and Dean R. B. (1970) Ammonia removal from secondary effluents by selective ion exchange. *J. Water Pollut. Control. Fed.*, 42, R95-R107.
- Minato H. and Tamura T. (1978) Production of oxygen and nitrogen with natural zeolites. In *Natural Zeolites: Occurrence, Properties, Use* (L. B. Sand and F. A. Mumpton, eds.), pp. 509-516. Pergamon, New York.
- Ming D. W. (1989) Manufactured soils at planetary bases for the growth of plants. In *Lunar Base Agriculture: Soils for Plant Growth* (D. W. Ming and D. L. Henninger, eds.), pp. 93-105. American Society of Agronomy, Madison.
- Ming D. W. and Henninger D. L. (1989) *Lunar Base Agriculture: Soils for Plant Growth*. American Society of Agronomy, Madison. 255 pp.
- Ming D. W. and Lofgren G. E. (1990) Crystal morphologies of minerals formed by hydrothermal alteration of synthetic lunar basaltic glass. In *Soil Micromorphology: A Basic and Applied Science* (L. A. Douglas, ed.), pp. 463-470. Elsevier, Amsterdam.
- Ming D. W. and Mumpton F. A. (1989) Zeolites in soils. In *Minerals in Soil Environments, 2nd edition* (J. B. Dixon and S. B. Weed, eds.), pp. 873-911. Soil Science Society of America, Madison.
- Mortland M. M. (1970) Clay organic complexes and interactions. *Adv. Agron.*, 22, 75-117.
- Mumpton F. A. (1975) Commercial utilization of natural zeolites. In *Industrial Minerals and Rocks, 4th edition* (S. J. Lefond, ed.), pp. 1262-1274. Amer. Inst. Mining Metall. Petrol. Engrs. Inc., New York.
- Mumpton F. A., ed. (1981) *Mineralogy and Geology of Natural Zeolites*. Reviews in Mineralogy, Vol. 4, Mineralogical Society of America, Washington, DC. 225 pp.
- Murakami Y., Iijima A., and Ward J. W., eds. (1986) *New Developments in Zeolite Science and Technology*. Elsevier, New York. 1091 pp.
- Pannaparayil T., Komarneni S., Breval E., Roy D. M., and Mulay I. N. (1985) Fe<sup>3+</sup>-substituted tobermorites: Synthesis and characterization by Mossbauer spectroscopy and other techniques. *Mater. Res. Bull.*, 20, 1393-1400.
- Pond W. G. and Mumpton F. A., eds. (1984) *Zeo-Agriculture: Use of Natural Zeolites in Agriculture and Aquaculture*. Westview, Boulder. 296 pp.
- Rabo J. A., ed. (1976) *Zeolite Chemistry and Catalysis*. American Chemical Society Monograph No. 171, Washington, DC. 796 pp.
- Sand L. B. and Mumpton F. A., eds. (1978) *Natural Zeolites: Occurrence, Properties, Use*. Pergamon, New York. 546 pp.
- Stewart H. A. and Heck J. L. (1969) Pressure swing adsorption. *Chem. Eng. Prog.*, 65, 78-83.
- Stoilov G. and Popov N. (1982) Agricultural uses of natural zeolites in Bulgaria (abstract). In *Zeo-Agriculture '82: A Conference on the Use of Natural Zeolites in Agricultural and Aquaculture*. p. 38. International Committee on Natural Zeolites, Rochester, New York.
- Talibudeen O. (1955) Complex formation between montmorillonoid clays and amino-acids and proteins. *Trans. Faraday Soc.*, 51, 582-590.
- Taylor H. F. W. (1964) The calcium silicate hydrates. In *The Chemistry of Cements* (H. F. W. Taylor, ed.), pp. 167-232. Academic, New York.
- Townsend R. P., ed. (1980) *The Properties and Applications of Zeolites*. The Chemical Society, Burlington House, London. 430 pp.
- Tucker D. S., Vaniman D. T., Anderson J. L., Clinard F. W., Feber R. C., Frost H. M., Meek T. T., and Wallace T. C. (1985) Hydrogen recovery from extraterrestrial materials using microwave energy. In *Lunar Bases and Space Activities of the 21st Century* (W. W. Mendell, ed.), pp. 583-590. Lunar and Planetary Institute, Houston.

- Webber D. A. (1972) Adsorptive removal of carbon dioxide from air at intermediate low temperatures. *Chem. Eng. (London)*, 257, 18-23.
- Weisz P. B. (1980) Molecular shape selective catalysis. *Pure Appl. Chem.*, 52, 2901-2103.
- Williams R. J. (1985) Oxygen extraction from lunar materials: An experimental test of an ilmenite reduction process. In *Lunar Bases and Space Activities of the 21st Century* (W. W. Mendell, ed.), pp. 551-558. Lunar and Planetary Institute, Houston.
- Williams R. J. and Jadwick J. J., eds. (1980) *Handbook of Lunar Materials*. NASA RP-1057, Washington, DC. 120 pp.
- Wirsching U. (1981) Experiments on the hydrothermal formation of calcium zeolites. *Clays Clay Miner.*, 29, 171-183.
- Young J. F. (1985) Concrete and other cement-based composites for lunar base construction. In *Lunar Bases and Space Activities of the 21st Century* (W. W. Mendell, ed.), pp. 391-397. Lunar and Planetary Institute, Houston.