

# CREATING A FOUNDATION FOR A SYNERGISTIC APPROACH TO PROGRAM MANAGEMENT

N 93 - 14017

Karyn T. Knoll

Lunar and Mars Exploration Office  
Mail Code IZ  
NASA Johnson Space Center  
Houston TX 77058

*Previous large, multicenter NASA programs have been accomplished by dividing the program into elements (e.g., command module, Saturn V booster, Orbiter) that were designed, developed, and integrated by a prime contractor under the management of a single NASA center. While this method minimized the managerial complexity of a given program, it created an organizational structure within the agency that makes it difficult for new NASA programs to effectively use hardware and resources developed for previous programs. Therefore, each new NASA program must essentially start from scratch. In order to accelerate the movement of humans into space within reasonable budgetary constraints, NASA must develop an organizational structure that will allow the agency to efficiently use all the resources it has available for the development of any program the nation decides to undertake. This work considers the entire set of tasks involved in the successful development of any program. Areas that hold the greatest promise of accelerating programmatic development and/or increasing the efficiency of the use of available resources by being dealt with in a centralized manner rather than being handled by each program individually are identified. Using this information, an agency organizational structure is developed that will allow NASA to promote interprogram synergisms. In order for NASA to efficiently manage its programs in a manner that will allow programs to benefit from one another and thereby accelerate the movement of humans into space, several steps must be taken. First, NASA must develop an organizational structure that will allow potential interprogram synergisms to be identified and promoted. Key features of the organizational structure recommended in this paper include (1) the establishment of a single office to perform the mission analysis and system engineering functions across all NASA programs and, therefore, to replace the performance of these functions as part of each individual program; and (2) the establishment of technical discipline agents to perform subsystem management on an agency-wide basis, as opposed to having each NASA center provide its own subsystem managers to support the development of those elements for which the center is responsible. Second, NASA must begin to develop the requirements for a program in a manner that will promote overall space program goals rather than achieving only the goals that apply to the program for which the requirements are being developed. Finally, NASA must consider organizing the agency around the functions required to support NASA's goals and objectives rather than around geographic locations. If we are serious about moving toward the permanent presence and expansion of humans into space, NASA must organize itself to be able to treat the space program as a program rather than as a collection of individual initiatives.*

During the early years of the Space Age, American endeavors in the area of manned spaceflight were generally accomplished through a series of relatively independent programs with fairly specific and well-defined goals. Often these programs were developed by dividing the program hardware into elements (usually, manned spacecraft elements and booster elements) that were designed, developed, and integrated by a single (prime) contractor under the management of a single NASA center. In 1988 President Reagan announced a "Space Policy and Commercial Space Initiative to Begin the Next Century," which contained the following major components: (1) establishing a long-range goal to expand human presence and activity beyond Earth orbit into the solar system; (2) creating opportunities for U.S. commerce in space; and (3) continuing our national commitment to a permanently manned space station.

In order to accomplish the ambitious, broadly defined kinds of goals that this policy set for the nation, NASA must be capable of undertaking a variety of highly interactive and dynamic programs with goals that will change and develop as each of these

programs is defined and realized. Because the existing NASA organizational structure was developed to enable the agency to respond to programs of a specific, well-defined nature, it is desirable to review this structure in terms of its capability to respond to the kinds of challenges that NASA will be undertaking in order to fulfill the charges of the national space policy. This paper examines the organizational structure currently in existence for the implementation of NASA programs, and proposes an agency architecture structured to provide the flexibility NASA requires in order to efficiently accomplish the kinds of programs involved in the achievement of our national goals in space.

Figure 1 presents an overview of the flow of the major functions involved in the development of a typical program. (For the sake of clarity, this flow is presented in a very basic and straightforward manner. The actual process, however, is highly interactive and iterative.) The mission analysis function collects the necessary data and performs the analyses required to transform the top-level goals and constraints for the program into a set of quantified requirements that tells the engineers responsible for designing the

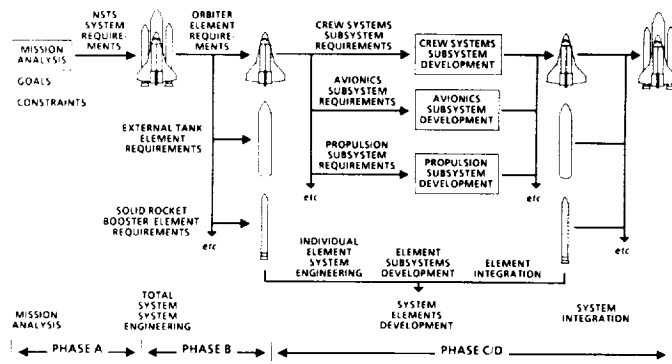

Fig. 1. Overview of the flow of a program.

system, in specific terms, just what they are supposed to design the system to be able to do. The mission requirements, which are output as the product of the mission analysis activity, serve as an input to the system engineering function of the total system that defines the configuration of the most efficient (lowest total cost) system capable of meeting the performance parameters specified by the mission requirements. To "define" the configuration of the system means to determine and specify the elements that compose the system, along with the requirements on each of these elements. The word "element," as used in this paper, refers to an essentially modular part of the total system in which the subsystems are relatively self-contained. Usually, though not always, this "modular, self-contained subsystems" property of an element is caused by the fact that the element functions as a separable, independent unit during some phase of the mission. The command module, the lunar module, the Saturn V booster, and the solid rocket boosters are all examples of elements. Although it does not separate during the mission, the main engines module of the space shuttle is also considered to be an element since it does fit this modular, self-contained subsystems definition. Additionally, this element is treated as an independent unit during processing. Under the above definition of an element, the mannedcore portion of the space station would be considered to be a single element that is divided into several subelements for development and assembly purposes.

The element requirements output by the total system system engineering function serve as input for the element development phase of the program. During this phase, elements that meet the element requirements are developed. In the accomplishment of this activity, the following major functions are performed for each element of the program.

1. Individual element system engineering that defines the configuration of the element that is most capable of meeting the requirements output by the total system system engineering function; to "define" the configuration of an element means to determine and specify the requirements on each subsystem (including the element unique equipment, which is also treated as a subsystem during this analysis) of the element.

2. Subsystems development that develops each subsystem in accordance with the subsystem requirements defined by the individual element system engineering function.

3. Element integration that combines the developed subsystems into an element that meets the requirements levied on the element by the total system system engineering function.

The final major function that must be performed in support of the development of a typical program is the system integration function, which combines the developed elements into a total system that meets the requirements levied on the system by the mission analysis function.

To accomplish the earlier major, manned programs for which NASA was responsible, such as the Apollo and space shuttle programs, NASA, together with its Phase B contractors, performed the total system system engineering function, which defined the elements constituting the total system and produced a set of requirements on each of these elements. These requirements were then used to write the Phase C/D requests for proposal (RFPs) for the development of these elements. Generally, one contract was awarded for each of the elements to be developed. This contract included responsibility for the performance of all the functions involved in the development of the element: the system engineering function that defined the requirements on the subsystems of the element (note that here the "system" referred to in the system engineering function is the element), the development of all the subsystems of the element, and the integration of these subsystems into an element. In addition to the element contracts, an integration contract (or a separate schedule) was awarded for the integration of the developed elements into a total system. This integration contract did not include any responsibility for the integration of an element's subsystems into the element. This type of element integration was handled as part of the contract for the development of each element.

The development contract for each element of a program was managed by a single NASA center. Additionally, each element of the earlier major, manned NASA programs could generally be related to some major function—propulsion, crew support (manned spacecraft), communications, or operations—required for the accomplishment of the program. For the Apollo program, as shown in Fig. 2a, centers were set up to provide expertise in these areas. Because the space shuttle was composed of elements with these same functions, the space shuttle program could be smoothly managed using the same structure that the agency developed in order to accomplish the Apollo program (Fig. 2b).

With the undertaking of the space station program, NASA assumed responsibility for the development of a program that could not be divided into a set of Apollo-like elements. In fact, as Fig. 3 illustrates, by the modular, self-contained subsystems definition of an element, the mannedcore space station is really a single element that has been divided into several subelements for development and assembly purposes. Since, in the case of the mannedcore space station, the element equals the total system, only the "inner loop" functions shown in Fig. 1, those associated with the development of a single element, are performed for the mannedcore element of the space station program. In order to handle this situation, NASA had to choose between awarding a single contract for all the functions—system engineering, subsystems development, and element integration—involved in the development of the mannedcore space station element, or changing the architecture of the agency enough to enable NASA itself to assume responsibility for the performance of these functions. The first option would allow NASA to develop the mannedcore space station element using the same programmatic methodologies the agency already has in place as a result of supporting its past programs; the second would incorporate some of the element development procedures formerly performed by the prime contractor for an element and would force NASA to manage

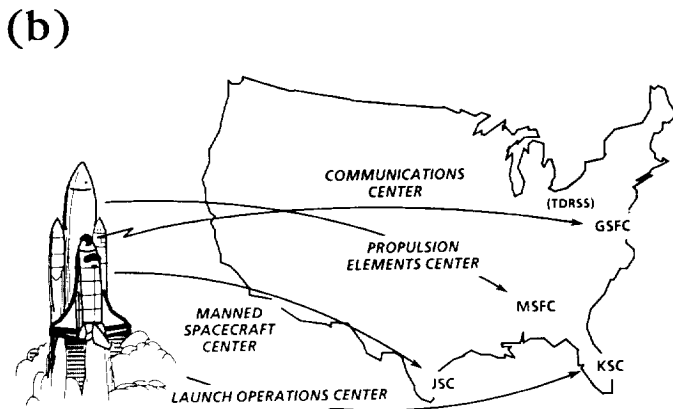
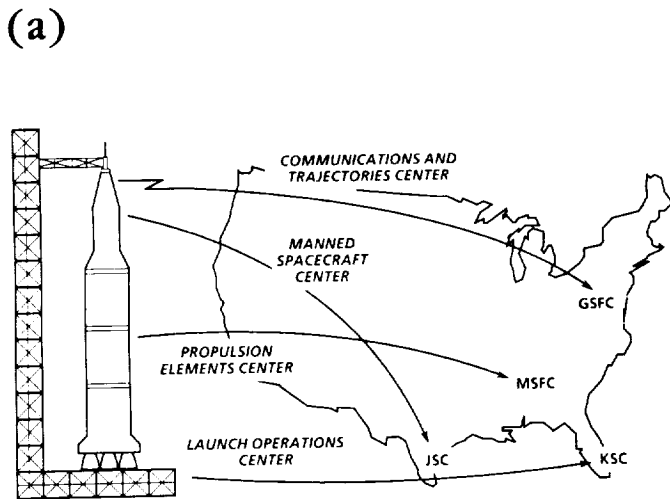

Fig. 2. (a) In the beginning: The Apollo program. (b) Continuing the tradition: The space shuttle program.

the contracts for the accomplishment of some of the specific activities (such as the development of a particular subsystem) involved in the development of an individual element. Previously, under the single contract method, the prime contractor for the element awarded and managed subcontracts for the performance of these element development tasks.

As NASA undertakes the programs required for the achievement of our national goals in space, it will assume responsibility for the development of many different types of aerospace systems—cargo and personnel transports, spaceports, surface habitats of both a temporary and a permanent nature, mining facilities, and so forth—that may not easily divide into manned spacecraft and booster-type elements for development purposes. In fact, as has already been illustrated, some systems may not efficiently divide into elements at all. In order to meet the challenges of the future, NASA will require an agency architecture that is flexible enough to support the development of a large variety of different types of aerospace elements.

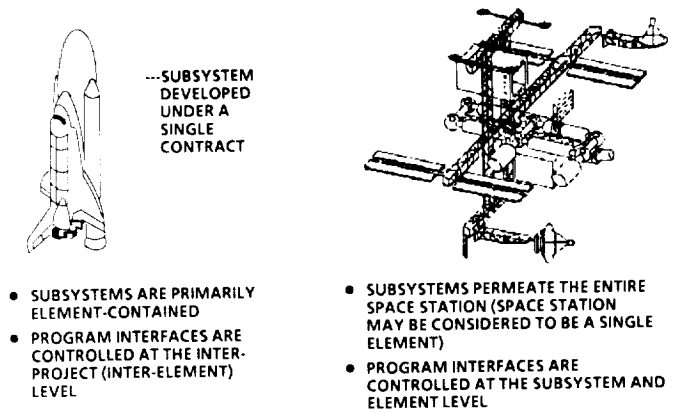

Fig. 3. Today's programs: A new way of doing business.

Additionally, each major, manned program undertaken by NASA has been the focus of attention of the agency for the duration of the program and has usually been completed before the development of the next major program was begun. Because past programs had fairly specific goals, each program could generally be structured as a means to the accomplishment of a limited set of objectives that terminated (or passed over from a development to an operational phase) when this set of objectives was achieved. For this reason, previous NASA programs were accomplished relatively independently of one another. The most notable exceptions occur in programs such as Apollo-Colo3 and Skylab that used hardware from a previous program. Even these programs, however, are simply cases of making use of already existing hardware rather than being examples of any type of "global" planning across several programs. (That is, the hardware was custom designed for the initial program. Later programs were then "forced-fit" to be able to make use of this existing hardware instead of designing the initial hardware to be the optimum hardware for all the programs that were expected to use it.)

In order to accomplish the broad, long-range kinds of goals specified by the national space policy, NASA will have to define, develop, and undertake sets of highly interactive programs that together achieve a high-level goal. As illustrated in Fig. 4, a lunar colony may consist of lunar science facilities, observation equipment for studying the universe, and a LOX facility that will provide propellants for transports to Mars. Although this colony is composed of elements that are satisfying the objectives of three different programs, it may be beneficial to design the colony so that the crew members supporting these elements all share the same habitat (and the same logistics support) and so that the elements all receive their power from the same power facility. Though developed under a number of different programs, the entire set of elements shown in the figure efficiently achieve the goal stated in the national space policy of "establishing a long-range goal to expand human presence and activity beyond Earth orbit and into the solar system." In order for the entire colony to function smoothly, all the elements of the lunar colony would have to be designed to "play together" as components of a single system. Additionally, the elements of this lunar colony would have to be capable of smoothly interfacing with the elements of the programs of which they are a part; i.e., the lunar observatories may have to coordinate with other Earth- or space-based equipment in order to provide complete data required for a

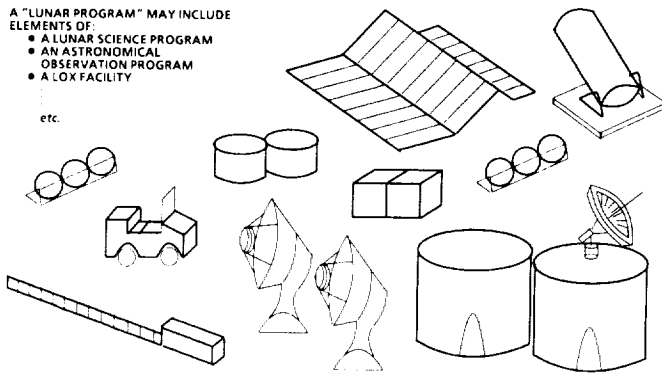

Fig. 4. The interactive nature of potential future programs.

particular astronomy experiment, the LOX facility will have to function in cooperation with the Mars transport vehicles for which it provides propellants, the entire colony must be able to interface with its resupply and logistics support network, and so forth. If NASA plans to undertake this type of ambitious scenario in the future, it will be necessary for the agency to develop the capability to define the requirements for each of its new programs in a manner that enables these programs to efficiently interact with the other agency programs and thereby promotes the overall goals of the space program rather than in a manner that will achieve only the goals of the individual program for which the requirements are being defined.

In summary, in order to achieve the goals that the U. S. has set for itself in space, NASA will require an architecture that enables the agency to: (1) develop the requirements on the elements of future agency programs in a manner that recognizes and accounts for the interactions that need to take place in order for the elements of these programs to function together as part of a single, coordinated, space program; and (2) handle the development of a variety of different types of elements.

In past programs, the system under development was optimized to achieve a set of mission requirements that were specific to the program itself. Any interactions with other programs could generally be handled as external interfaces with already developed systems (thereby making these interfaces very specific; such interfaces could generally be handled as being constraints on the program). Anticipated interactions, or optimum trade-offs, with elements of projected future systems were rarely considered. Instead, when such future programs did reach the development stage, they would handle any necessary interactions with the previous program as being constraints on the new program. This situation meant that a system could be defined by considering only those interactions taking place between the elements of the system itself. If, however, NASA now plans to begin serious consideration of the interactive types of programs required for the achievement of the ambitious kinds of goals specified in the national space policy, it will be necessary to consider the interactions and optimum trade-offs occurring between the elements of a number of systems that will be developed at different times under different programs. This new set of circumstances suggests that those functions leading to the definition of the elements of a given program—the mission analysis and total system system engineering functions (refer to Fig. 1)—should be replaced by a function that analyzes the

interactions and optimizes the trade-offs between the elements of all the programs (or potential programs) that make up the nation's space program. This situation, illustrated in Fig. 5, implies that NASA should consider replacing the mission analysis and total system system engineering functions previously performed as part of each individual agency program with a single "program engineering" (where "program" here refers to the whole space program) function that serves the entire agency. An agency program engineering office should be set up to implement this function.

Although an explanation of the program engineering process is beyond the scope of this paper, a few points should be mentioned. The program engineering process is basically a system engineering process in which the "system" under analysis is the entire space program. Beginning with broad categories of missions that offer the potential for furthering our national goals in space (for example, perform a thorough scientific study of the Moon, study the universe beyond our solar system, perform a thorough scientific study of Mars, and so forth), the specific experiments and processes (or candidate options for experiments and processes) required for the accomplishment of each mission category are identified. The mission analyses and system engineering studies required to accomplish this set of experiments and processes are performed in such a manner that any synergies and beneficial trade-offs between these mission activities and the systems designed to support their implementation are identified. (The program engineering process would identify, for example, that some of the equipment used to perform observations of the universe can, or should be, lunar-based, and that the crew members required to operate and maintain this equipment could share a habitat with lunar crew members performing lunar science experiments and those operating a LOX facility producing propellants for transports to Mars. The number, character (content or "set of elements"), and time-phasing of the most efficient set of programs leading to the accomplishment of the complete set of input mission categories is produced as an output of the program engineering process. Notice the "crossovers" that occur between input missions and the programs in which these missions are actually implemented. (Some of the observation equipment used to support the Study of the Universe mission category may be developed as part of a lunar program, and other

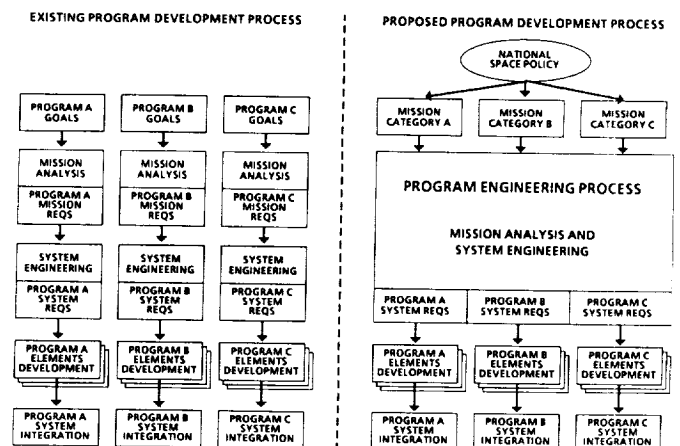

Fig. 5. NASA program development process.

equipment supporting such a mission may end up being developed as part of a low-Earth-orbit program; the LOX facility, though supporting a Mars mission, may itself be developed as part of a lunar program; and so forth.) Another important point that should be mentioned in regard to the program engineering process is that, although this process should be the responsibility of a single office (the agency program engineering office), it is not expected that all the personnel needed to perform this process would be located in that office. The agency program engineering office itself should direct and coordinate the studies and analyses required for the performance of the program engineering process and should interpret the results leading to the definition of the elements (and programs) needed to accomplish our national goals in space. The actual performance of the studies and analyses required to support the program engineering process should be performed by the NASA institution located at the field centers.

Although the establishment of an agency program engineering office for the performance of the program engineering function will enable NASA to define the elements of its programs in a manner that optimizes the interactions between these elements, the problem of determining an organizational structure that will allow the agency to efficiently develop any type of element defined as an output of this process still remains. Figure 6 suggests a solution to this situation by pointing out that all the elements defined by the total system system engineering function (or by the program engineering function that replaces it in the case of highly interactive programs) are basically composed of the same kinds (though not necessarily the same architecture) of subsystems.

As Fig. 7a illustrates, in managing the development of the elements of past programs, NASA used subsystem managers who were located at the same center as the project office for the element they supported and who developed expertise in the types of subsystems associated with that element. This meant that each center developed a pool of experts who were adept at understanding a particular set of subsystem architectures associated with the elements that had been developed at that center. During the Apollo program, which had the unique opportunity of structuring the agency to meet its needs (see Fig. 2a), and the space shuttle program, which resembled the Apollo program in terms of programmatic structure (see Fig. 2b), this subsystem manager arrangement worked well. However, as NASA moves toward a future that envisions expansions into new areas of space exploration and begins the undertaking of the programs required for the realization of this vision, it is very likely that the current approach to programs in which almost all the personnel

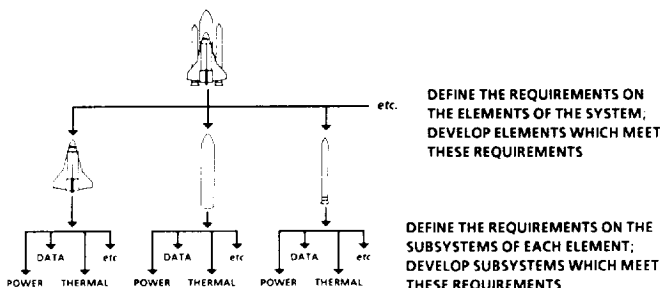

Fig. 6. Program definition and development.

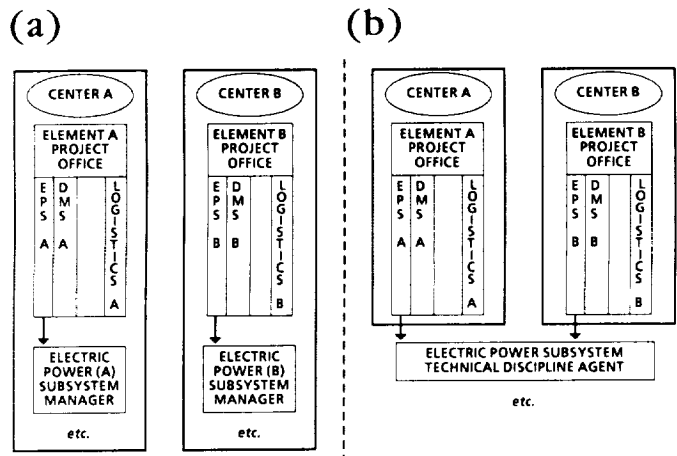

Fig. 7. Use of technical discipline agents for consolidation of subsystem management: (a) Existing subsystem management structure in which each center provides its own subsystem managers for every subsystem of the element(s) for which the center is responsible; (b) proposed subsystem management structure in which, for a given subsystem, the same technical discipline agent provides subsystem management for all elements in the agency.

(including the subsystem managers) associated with the development of an element work directly for the center responsible for the element will prove to be too inflexible to allow NASA to efficiently manage the variety of new programs the agency will be undertaking in the near future. One of the problems likely to be encountered in the future is the need to reassign personnel and to redirect the use of facilities that were involved in the development of a program after the program moved into its operational stage. This problem becomes especially acute when the center is not assigned responsibility for the development of a new element (which is one of the motivations behind the competition between centers that is sometimes observed during the assignment of the elements of a new program). Another problem that may be encountered is an unnecessary duplication of effort between different centers caused by the fact that, under the current NASA organizational structure, it is easier for a center to establish its own expertise in a particular technical discipline than it is to access already established expertise located at another center. Yet another potential problem is the probability of mismatches occurring between center expertise and the assignment of the development of an element to a particular center. Such mismatches are caused by the fact that in the past, when NASA assigned the development of an element to a center, this assignment included the development of all the subsystems within the element, even if the expertise in some of the subsystems was located at another center. As NASA begins to assume responsibility for the development of a large variety of elements, a situation develops in which the expertise in some of the subsystems of an element will be located at one center, while the expertise in other subsystems will be located at other centers. NASA must then solve how to assign the development of the element to a particular center while efficiently making use of all the center expertise, with its associated resources (test beds, research facilities, databases, and so forth) available throughout the agency. As Fig. 7b illustrates, one method of alleviating this situation is by establishing a technical discipline agent for each of the subsystems involved in the development of a typical aerospace element. These

agents are groups (possibly divisions or small directorates) of technical personnel set up to provide support in their technical discipline to any NASA program requiring such support, regardless of where the program or project office requiring the support was located. (In order to maximize the effectiveness of technical discipline agents, it is recommended that NASA investigate the feasibility of standardizing the types, though not the architectures, of subsystems associated with the development of any given element.) By eliminating the need for each technical discipline agent to be located at the same center as the office it supports, technical discipline agents offer one potential method for providing NASA with the flexibility it requires to support a variety of new programs. As one program ends or scales down for a period of time, the manager of a technical discipline agent can reassign the personnel who were supporting the program to new programs just beginning to require support. Such reassignments can be made regardless of where the project offices for the new program are located.

The establishment of an agency program engineering office and technical discipline agents are suggested as methods for the solution of specific problems expected to be encountered as the agency begins undertaking the kinds of programs involved in the achievement of our future national goals in space. Still remaining is the consideration of an organizational structure, with its associated lines of authority or management structure, which combines these concepts with the other functions required for the successful accomplishment of a program in a manner flexible enough to accommodate the development of any set of programs that the nation decides to undertake in space. Figure 8a illustrates the current NASA organizational structure in which all employees located at a given center, including those in any program or project office located at the center, are under the direct management of the director of the center. Each center is, in turn, under the management of a specific code. During the Apollo program, when centers were established to provide specific functions in support of the development of the program, and these functions were consistent with the responsibilities of the code that managed the center, such an organizational structure worked well; that is, the organizational structure was consistent with the structure of the program it was managing. Since the Apollo program, however, NASA has managed the development of an ever-increasing variety of programs. Taking on new kinds of programs without modifying the structure of the agency to be consistent with the needs of these new programs has left NASA with a structure that possesses significant gaps and inconsistencies in some of the lines of communication and authority involved in the implementation of its programs. For example, during Phase B of the space station program, the program manager did not answer directly to the associate administrator for the space station program (Code S). Instead, the program manager answered to the center director of the center at which the program office was located (the Johnson Space Center, in this case), who, in turn, answered to the associate administrator for manned spaceflight (Code M). The associate administrator for manned spaceflight and the associate administrator for the space station program were organizational equals, both of whom answered to the administrator. Similarly, there were no direct lines of communication between the program manager and the projects office managers for each of the work packages of the space station program. Each projects office manager answers to the director of the center at which the projects office is located who, in turn, answers to the associate administrator of the code responsible for that center. Today,

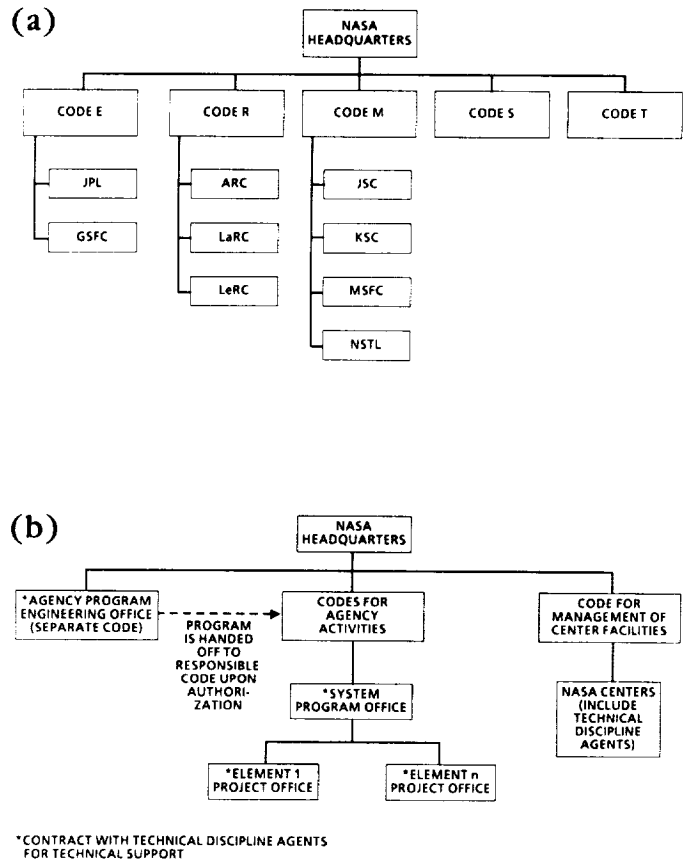

Fig. 8. (a) Existing NASA organizational structure; (b) proposed NASA organizational structure.

although the program manager (now called the program director) has been moved to the office of the associate administrator for the space station program, the lines of authority directing projects managers are still somewhat unclear. There are several similar situations throughout the agency in which personnel involved in the accomplishment of a program, which is the development responsibility of one code, work for a center managed by another code. The lines of authority in these cases are often somewhat ambiguous. This situation will certainly affect the agency's ability to efficiently manage the programs it will be undertaking in the future.

In order to provide more direct lines of authority between the agents involved in the implementation of future programs, this paper suggests that NASA consider employing an organizational structure like that illustrated in Fig 8b. Under the arrangement shown in this figure, a program is developed through the Phase B level (that is, through to the determination of the requirements on the elements of the program) by the agency program engineering office, which is part of its own code, separate from the other NASA codes. Upon authorization of a particular program, responsibility for the program is handed off to the code that has been assigned responsibility for the development of the program. For example, responsibility for the development of an unmanned planetary exploration program may be handed off to Code E,

responsibility for the development of a manned program may be handed off to Code M, responsibility for the development of an especially large program may be handed off to a new code created for the management of its development (like the space station program), and so forth. Upon authorization of a particular program, the responsible code sets up a program office to manage the development of the overall program and a project office for each element of the program to manage the development of its respective element. Regardless of the location of each program or project office, all the personnel in the office answer directly to the program manager who, in turn, answers directly to the associate administrator of the code responsible for the development of the program. That is, all personnel in the program-related offices are badged to the NASA code responsible for the development of the program. (This situation is somewhat analogous to that employed by the Air Force in which all personnel under a particular Command are considered to be part of that Command regardless of the base at which they are physically stationed.) Additionally, Fig. 8b recommends the establishment of a new code to be responsible for the management of the facilities of all the centers in the agency. All centers would be managed by this code (i.e., all center directors would be under the authority of the associate administrator for this code), which, through its center directors, would be responsible for insuring that the personnel located at each center were provided with the proper resources and support required to accomplish their job, no matter which agency code they were attached to. Additionally, any personnel who were specific to the center, like the technical discipline agents located at the center, would be under the managerial authority of the center director who, in turn, would be under the authority of the associate administrator for the center management code. The technical discipline agents would provide technical support in their disciplines to all NASA program and project

offices as well as to the agency program engineering office on a "contract for services required" basis. These technical discipline agents would provide the services previously performed by the subsystem managers in past NASA programs, as well as the support the agency program engineering office and the project offices will require in order to perform the program engineering and contract management functions for which they are responsible.

In conclusion, this paper attempts to provide a strawman architecture that addresses some of the new kinds of problems with which NASA will most likely be expected to have to deal as it undertakes the ambitious types of programs suggested by our national space policy. This proposed architecture has been developed by primarily concentrating on concerns that are specific to the successful development of NASA programs. In undertaking the development of a complete architecture for the agency, NASA will have to determine how the development of the programs for which the agency is responsible fits into the complete set of activities with which NASA is concerned. Any architecture adopted by the agency should, as a minimum, however, enable it to (1) determine the requirements on the elements of future agency programs in a manner that accounts for the interactive nature of these programs, and (2) assign the development of any type of program element to the various factions of the agency that will be involved in this development in a manner that efficiently uses all the resources available to the agency. Finally, it is recommended that NASA thoroughly review any organizational structure that the agency considers adopting to insure that the structure is complete and consistent. A collection of isolated solutions to the individual problems encountered as NASA takes on the challenges of the future will not be sufficient to see it through the development and operation of the large-scale, highly interactive kinds of programs for which it will be responsible as we move into the next century.